

PTB

SALES

FOR SALES AND SERVICE PLEASE CALL:

PTB SALES T :: 626.334.0500
service@ptbsales.com
www.ptbsales.com

DATE SERVICED: _____

VIEW OUR INVENTORY

**Manuale di istruzioni
Bedienungshandbuch
Notice de mode d'emploi
Manual de instrucciones
Manual de instruções
Bedrijfshandleiding
Instruktionsbog
Bruksanvisning**

Turbo-V 3K-T Rack Controller

Models

869-9447, 869-9547

**Instruksjon manual
Ohjekäsikirja
Felhasználói kézikönyv
Podrecznik instrukcji
Návod k použití
Návod na obsluhu
Priročnik za navodila
User Manual**

87-900-988-01 (D)

11/2011



Agilent Technologies

Notices

© Agilent Technologies, Inc. 2011

No part of this manual may be reproduced in any form or by any means (including electronic storage and retrieval or translation into a foreign language) without prior agreement and written consent from Agilent Technologies, Inc. as governed by United States and international copyright laws.

Manual Part Number

Publication Number: 87-900-988-01 (D)

Edition

Edition 11/2011

Printed in ITALY

Agilent Technologies Italia S.p.A.

Vacuum Products Division

Via F.lli Varian, 54

10040 Leini (TO)

ITALY

Warranty

The material contained in this document is provided “as is,” and is subject to being changed, without notice, in future editions. Further, to the maximum extent permitted by applicable law, Agilent disclaims all warranties, either express or implied, with regard to this manual and any information contained herein, including but not limited to the implied warranties of merchantability and fitness for a particular purpose. Agilent shall not be liable for errors or for incidental or consequential damages in connection with the furnishing, use, or performance of this document or of any information contained herein. Should Agilent and the user have a separate written agreement with warranty terms covering the material in this document that conflict with these terms, the warranty terms in the separate agreement shall control.

Technology Licenses

The hardware and/or software described in this document are furnished under a license and may be used or copied only in accordance with the terms of such license.

Restricted Rights Legend

If software is for use in the performance of a U.S. Government prime contract or subcontract, Software is delivered and licensed as “Commercial computer software” as defined in DFAR 252.227-7014 (June 1995), or as a “commercial item” as defined in FAR 2.101(a) or as “Restricted computer software” as defined in FAR 52.227-19 (June 1987) or any equivalent agency regulation or

contract clause. Use, duplication or disclosure of Software is subject to Agilent Technologies’ standard commercial license terms, and non-DOD Departments and Agencies of the U.S. Government will receive no greater than Restricted Rights as defined in FAR 52.227-19(c)(1-2) (June 1987). U.S. Government users will receive no greater than Limited Rights as defined in FAR 52.227-14 (June 1987) or DFAR 252.227-7015 (b)(2) (November 1995), as applicable in any technical data.

Trademarks

Windows and MS Windows are U.S. registered trademarks of Microsoft Corporation.

Safety Notices

CAUTION

A **CAUTION** notice denotes a hazard. It calls attention to an operating procedure, practice, or the like that, if not correctly performed or adhered to, could result in damage to the product or loss of important data. Do not proceed beyond a **CAUTION** notice until the indicated conditions are fully understood and met.

WARNING

A **WARNING** notice denotes a hazard. It calls attention to an operating procedure, practice, or the like that, if not correctly performed or adhered to, could result in personal injury or death. Do not proceed beyond a **WARNING** notice until the indicated conditions are fully understood and met.

Turbo-V 3K-T Rack Controller



Contents

1 Istruzioni per l'uso 13

Informazioni Generali	14
Immagazzinamento	14
Preparazione per l'installazione	15
Installazione	16
Uso	17
Procedure di uso	20
Manutenzione	20
Smaltimento	21
Messaggi di errore	22

2 Gebrauchsanleitung 25

Allgemeines	26
Lagerung	26
Vor der Installation	27
Installation	28
Gebrauch	29
Bedienung	32
Wartung	32
Entsorgung	33

Contents

Fehlermeldungen	34
3 Mode d'emploi	37
Indications generales	38
Emmagasinage	38
Preparation pour l'installation	39
Installation	40
Utilisation	41
Procedures d'utilisation	44
Entretien	44
Mise au rebut	45
Messages d'erreur	46
4 Manual de instrucciones	49
Información general	50
Almacenamiento	50
Preparación para la instalación	51
Instalación	52
Uso	52
Procedimientos de uso	56
Mantenimiento	56
Eliminación	57
Mensajes de error	58

5	Manual de Instruções	61
	Informações gerais	62
	Armazenagem	62
	Preparação para a instalação	63
	Instalação	64
	Utilização	65
	Procedimentos de uso	68
	Manutenção	68
	Eliminação	69
	Mensagens de erro	70
6	Bedrijfshandleiding	73
	Algemene informatie	74
	Opslag	74
	Vorbereiding voor installatie	75
	Installatie	76
	Gebruik	77
	Gebruiksprocedures	80
	Onderhoud	80
	Afvalverwerking	81
	Foutmeldingen	82
7	Istruktionsbog	85
	Generel Information	86

Contents

Opbevaring	86
Forberedelser før installation	87
Installation	88
Anvendelse	89
Instruktion	92
Vedligeholdelse	92
Bortskaffelse	93
Fejlmeddelelser	94

8 Bruksanvisning 97

Allmän Information	98
Förvaring	98
Förberedelser för installation	99
Installation	100
Användning	101
Instruktioner för bruk	104
Underhåll	104
Bortskaffning	105
Felmeddelanden	106

9 Instruksjon Manual 109

Generell informasjon	110
Lagring	110
Forberede installasjonen	111

Installasjon	112
Bruk	112
Instruksjoner for bruk	116
Vedlikehold	116
Eliminering	117
Feilmeldinger	118
10 Ohjekäsikirja	121
Yleisiä tietoja	122
Varastointi	122
Valmistelut asennusta varten	123
Asennus	124
Käyttö	125
Käyttötoimenpiteet	128
Huolto	128
Hävittäminen	129
Vianetsintä	130
11 Felhasználói Kézikönyv	133
Általános információk	134
Tárolás	134
A telepítésre való előkészítés	135
Telepítés	136
Használat	137

Contents

Használati eljárások 140

Karbantartás 140

Megsemmisítés 141

Hibaüzenetek 142

12 Podrecznik Instrukcji 145

Informacje ogólne 146

Magazynowanie 146

Przygotowanie do instalacji 147

Instalacja 148

Użytkowanie 149

Procedure użytkowania 152

Konserwacja 152

Przetworstwo odpadów 153

Błędne informacje 154

13 Návod k Použití 157

Všeobecné informace 158

Uskladnění 158

Příprava k instalaci 159

Instalace 160

Použití 161

Používané procedury 164

Údržba 164

Likvidace	165
Chybné zprávy	166

14 Návod na Obsluhu 169

Všeobecné informácie	170
Uskladňovanie	170
Príprava pre inštaláciu	171
Inštalácia	172
Použitie	173
Postup pri použití	176
Údržba	176
Likvidácia	177
Oznamy väd	178

15 Priročnik za Navodila 181

Splošne informacije	182
Skladiščenje	182
Priprava za montažo	183
Montaža	184
Uporaba	185
Postopki uporabe	188
Vzdrževanje	188
Odlaganje odpadkov	189
Obvestilo o napaki	190

Contents

16 Instructions for Use 193

General information	194
Storage	194
Preparation for installation	195
Installation	196
Use	197
Use procedure	200
Maintenance	200
Disposal	201
Error messages	202

17 Technical Information 205

Turbo-V 3KT Rack Controller Description	207
Controller Specifications	209
Controller Outline	210
Fuse holder and voltage changer assembly	211
Interconnections	212
Optional serial port	219
Examples	225
Use	232
Orderable Parts	255



1

Istruzioni per l'uso

Informazioni Generali	14
Immagazzinamento	14
Preparazione per l'installazione	15
Installazione	15
Uso	17
Comandi, Indicatori e Connettori del Controller	18
Procedure di uso	18
Accensione del Controller	20
Avvio della Pompa	20
Arresto della Pompa	20
Manutenzione	20
Smaltimento	20
Messaggi di errore	22

Traduzione delle istruzioni originali



Informazioni Generali

Questa apparecchiatura è destinata ad uso professionale. L'utilizzatore deve leggere attentamente il presente manuale di istruzioni ed ogni altra informazione addizionale fornita dalla Agilent prima dell'utilizzo dell'apparecchiatura. La Agilent si ritiene sollevata da eventuali responsabilità dovute all'inosservanza totale o parziale delle istruzioni, ad uso improprio da parte di personale non addestrato, ad interventi non autorizzati o ad uso contrario alle normative nazionali specifiche. I controller della serie Turbo-V 3KT sono dei convertitori di frequenza, controllati da un microprocessore, realizzati con componenti a stato solido e con capacità di autodiagnostica e autoprotezione.

Questo manuale utilizza le seguenti convenzioni:

ATTENZIONE!

I messaggi di attenzione sono visualizzati prima di procedure che, se non osservate, potrebbero causare danni all'apparecchiatura.

AVVERTENZA!



I messaggi di avvertenza attirano l'attenzione dell'operatore su una procedura o una pratica specifica che, se non eseguita in modo corretto, potrebbe provocare gravi lesioni personali.

NOTA

Le note contengono informazioni importanti estrapolate dal testo.

Immagazzinamento

Durante il trasporto e l'immagazzinamento dei controller devono essere soddisfatte le seguenti condizioni ambientali:

- temperatura: da -20 °C a +70 °C
- umidità relativa: 0 – 95 % (senza condensa)

Preparazione per l'installazione

Il controller viene fornito in un imballo protettivo speciale; se si presentano segni di danni, che potrebbero essersi verificati durante il trasporto, contattare l'ufficio vendite locale. Durante l'operazione di disimballaggio, prestare particolare attenzione a non lasciar cedere il controller e a non sottoporlo ad urti. Non disperdere l'imballo nell'ambiente. Il materiale è completamente riciclabile e risponde alla direttiva CEE 85/399 per la tutela dell'ambiente.



Figura 1 Imballo dei controllers

Ogni controller è fornito dalla Agilent predisposto per una certa tensione di alimentazione:

- il modello 869-9447 per 220 Vac
- il modello 869-9547 per 120 Vac

Verificare che sia stata selezionata la tensione corretta e quindi ricollegare il cavo di alimentazione.

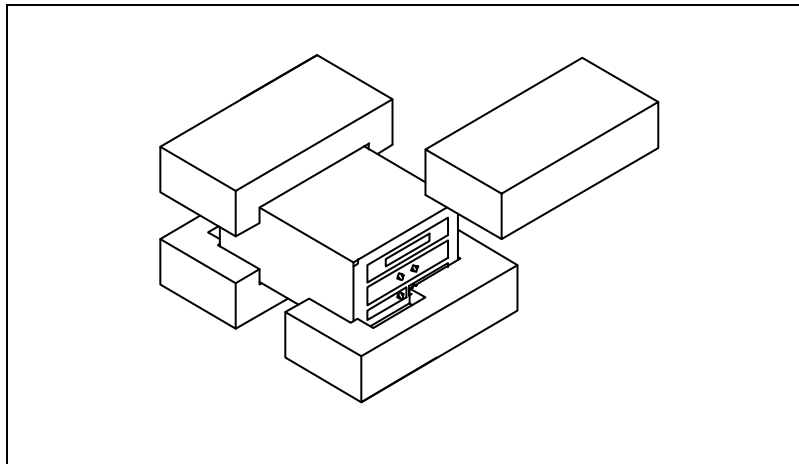
Installazione

AVVERTENZA!



Il controller è fornito di un cavo di alimentazione a tre fili con una spina di tipo approvato a livello internazionale. Utilizzare sempre questo cavo di alimentazione ed inserire la spina in una presa con un adeguato collegamento di massa onde evitare scariche elettriche. All'interno del controller si sviluppano alte tensioni che possono recare gravi danni o la morte. Prima di eseguire qualsiasi operazione di installazione o manutenzione del controller scollegarlo dalla presa di alimentazione.

NOTA

Il controller può essere installato su di un tavolo o all'interno di un apposito rack. In ogni caso occorre che l'aria di raffreddamento possa circolare liberamente intorno all'apparato. Non installare né utilizzare il controller in ambienti esposti ad agenti atmosferici (pioggia, gelo, neve), polveri, gas aggressivi, in ambienti esplosivi o con elevato rischio di incendio.

Durante il funzionamento è necessario che siano rispettate le seguenti condizioni ambientali:

- temperatura: da 0 °C a +40 °C;
- umidità relativa: 0 – 95 % (non condensante).

Per il collegamento del controller con la relativa pompa utilizzare il cavo specifico del controller stesso.

Per gli altri collegamenti e l'installazione degli accessori opzionali, vedere la sezione "Technical Information".

Uso

In questo paragrafo sono riportate le principali procedure operative. Per ulteriori dettagli e per procedure che coinvolgono collegamenti o particolari opzionali, fare riferimento al paragrafo "Use" dell'appendice "Technical Information".

Prima di usare il controller effettuare tutti i collegamenti elettrici e pneumatici e fare riferimento al manuale della pompa collegata.

AVVERTENZA!



Per evitare danni alle persone ed all'apparato, nel caso in cui la pompa sia appoggiata su di un tavolo assicurarsi che sia stabile. Non fare funzionare mai la pompa se la flangia di ingresso non è collegata al sistema o non è chiusa con la flangia di chiusura.

NOTA

Il connettore di richiusura J1 deve essere lasciato collegato con il suo ponticello se non viene effettuato alcun collegamento esterno. La pompa di pre-vuoto e la pompa Turbo-V possono essere accese contemporaneamente.

Comandi, Indicatori e Connettori del Controller

Di seguito sono illustrati il pannello di comando del Controller ed i pannelli di interconnessione. Per maggiori dettagli fare riferimento alla sezione "Technical Information".



Figura 2 Pannello frontale del Controller 869-9447 e 869-9547

- | | |
|---|--|
| 1 | Pulsante per la selezione del modo HIGH/LOW SPEED. È attivo solo quando è selezionato il modo di comando dal pannello frontale. Premendolo ripetutamente, si passa ciclicamente da HIGH SPEED a LOW SPEED. |
| 2 | Pulsante per inviare i comandi di START, STOP o RESET. È attivo solo quando è selezionato il modo di comando dal pannello frontale. Premendolo una volta si attiva la fase di avvio; premendolo nuovamente si arresta la pompa. Se la pompa si è fermata automaticamente a causa di un guasto, occorre premere questo pulsante una prima volta per eseguire il reset del controller ed una seconda volta per riavviare la pompa. |
| 3 | Pulsante per richiamare sul display i parametri cycle number, cycle time e pump life e numero seriale. |
| 4 | Pulsante per richiamare sul display i parametri pump current, pump temperature, pump power, rotational speed, valore del flusso rilevato. È sempre attivo indipendentemente dal modo di funzionamento scelto. Premendo assieme i pulsanti 3 e 4 per almeno 2 secondi viene attivato un programma con il quale è possibile selezionare alcuni parametri operativi. |
| 5 | Display alfanumerico a cristalli liquidi: matrice di punti, 2 linee x 16 caratteri. |

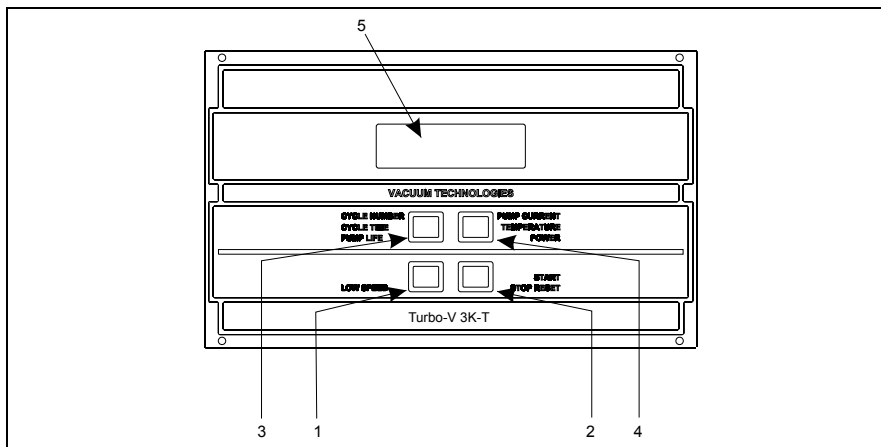

Figura 3 Pannello posteriore dei controller 869-9447 e 869-9547

1	Connettore di ingresso dei segnali logici (il connettore di accoppiamento viene fornito con l'apposito ponticello di richiusura).
2	Connettore di uscita dei segnali logici e di verifica della corrente della pompa e della frequenza di eccitazione.
3	Vano previsto per il connettore della porta di comunicazione seriale RS-232 – RS-485 (fornita come opzione).
4	Connettore di spurgo.
5	Modulo di ingresso dell'alimentazione per il Controller. Comprende il fusibile di protezione, il cambia tensione, la presa di alimentazione di potenza ed il filtro EMC.
6	Interruttore di linea.
7	Collegamento di terra.
8	Connettore cavo pompa.

Procedure di uso

Accensione del Controller

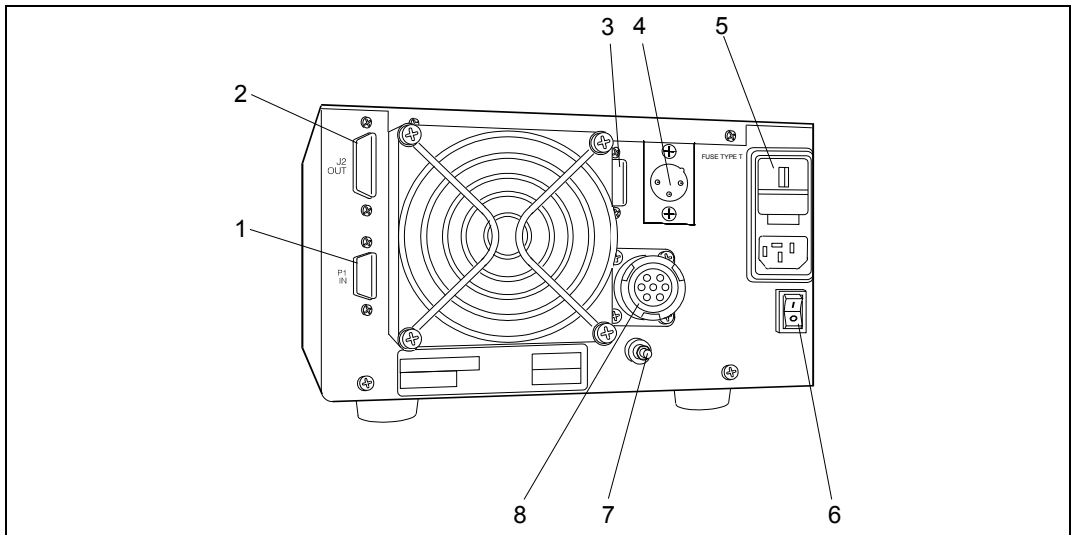
Per accendere il controller è sufficiente inserire il cavo di alimentazione nella presa di rete e portare l'interruttore di linea in posizione 1.

Avvio della Pompa

Per avviare la pompa occorre premere il pulsante START del pannello frontale.

Arresto della Pompa

Per arrestare la pompa occorre premere il pulsante STOP del pannello frontale.

Manutenzione

I controller della serie Turbo-V 3K-T non richiedono alcuna manutenzione. Qualsiasi intervento deve essere eseguito da personale autorizzato. In caso di guasto è possibile usufruire del servizio di riparazione Agilent o del "Agilent advanced exchange service", che permette di ottenere un controller rigenerato in sostituzione di quello guasto.

AVVERTENZA!

Prima di effettuare qualsiasi intervento sul controller scollegare il cavo di alimentazione.



Qualora un controller dovesse essere rottamato, procedere alla sua eliminazione nel rispetto delle normative nazionali specifiche.

Smaltimento

Significato del logo "WEEE" presente sulle etichette. Il simbolo qui sotto riportato è applicato in ottemperanza alla direttiva CE denominata "WEEE". Questo simbolo (**valido solo per i paesi della Comunità Europea**) indica che il prodotto sul quale è applicato, **NON** deve essere smaltito insieme ai comuni rifiuti domestici o industriali, ma deve essere avviato ad un sistema di raccolta differenziata. Si invita pertanto l'utente finale a contattare il fornitore del dispositivo, sia esso la casa madre o un rivenditore, per avviare il processo di raccolta e smaltimento, dopo opportuna verifica dei termini e condizioni contrattuali di vendita.

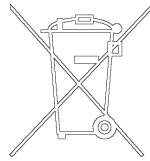

Messaggi di errore

In alcuni casi di guasto la circuiteria di autodiagnosi del controller presenta alcuni messaggi di errore elencati nella tabella riportata nella pagina seguente.

Tab. 1

Messaggio	Descrizione	Azione correttiva
CHECK CONNECTION TO PUMP	Malfunzionamento nel collegamento tra pompa e controller	Verificare che il cavo di collegamento tra pompa e controller sia ben fissato da entrambe le estremità e non sia interrotto. Premere due volte il pulsante START per riavviare la pompa.
PUMP WAITING INTERLOCK	È attivo il segnale di interlock presente sul connettore P1 a causa dell'interruzione del corto circuito tra il pin 3 ed il pin 8 del connettore J1, o a causa dell'apertura del segnale di interlock esterno.	Ripristinare il corto circuito tra il pin 3 ed il pin 8 del connettore J1, o chiudere il segnale di interlock esterno
FAULT: PUMP OVERTEMP.	La temperatura del cuscinetto superiore della pompa ha superato i 60 °C.	Attendere che la temperatura ritorni al di sotto della soglia. Premere due volte il pulsante START per riavviare la pompa.
FAULT: CONTROLLER OVERTEMPERATURE	La temperatura del trasformatore del controller ha superato i 90 °C.	Attendere che la temperatura ritorni al di sotto della soglia. Premere due volte il pulsante START per riavviare la pompa.

Messaggio	Descrizione	Azione correttiva
FAULT: TOO HIGH LOAD	Durante il funzionamento normale la corrente assorbita dalla pompa è maggiore di quella programmata.	Verificare che il rotore della pompa abbia la possibilità di ruotare liberamente. Premere due volte il pulsante START per riavviare la pompa.
FAULT: SHORT CIRCUIT	Durante il funzionamento normale (dopo la fase di avvio) la connessione di uscita è in corto circuito.	Verificare i collegamenti tra pompa e controller. Premere due volte il pulsante START per riavviare la pompa.
OVERVOLTAGE	Si è verificato un guasto nella sezione di alimentazione del controller, o il controller ha ricevuto un segnale spurio.	Premere due volte il pulsante START per riavviare la pompa. Se il messaggio si ripresenta rivolgersi alla Agilent per la manutenzione.
FLOW METER ALARM	Allarme relativo al flusso di purge. Il valore del flusso è rimasto ad un valore inferiore alla soglia impostata, per un tempo maggiore o uguale a 10 secondi.	Controllare il corretto funzionamento del circuito di alimentazione del gas.

1 Istruzioni per l'uso
Messaggi di errore

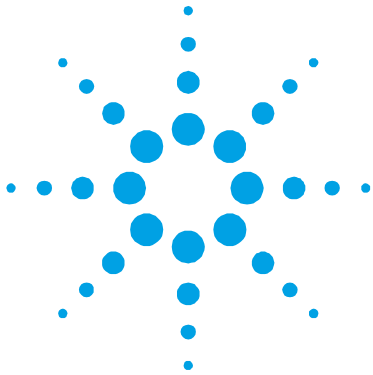

2 Gebrauchsanleitung

Allgemeines	26
Lagerung	26
Vor der Installation	27
Installation	28
Gebrauch	29
Steuerungen, Anzeigen und Verbinder des Controllers	29
Bedienung	32
Einschalten des Controllers	32
Pumpenstart	32
Pumpenstopp	32
Wartung	32
Entsorgung	33
Fehlermeldungen	34

Übersetzung der Originalanleitungen



Allgemeines

Dieser Apparat ist für Fachbetriebe bestimmt. Vor Gebrauch sollte der Benutzer dieses Handbuch sowie alle weiteren mitgelieferten Zusatzdokumentationen genau lesen. Bei Nichtbeachtung - auch teilweise - der enthaltenen Hinweise, unsachgemäßem Gebrauch durch ungeschultes Personal, nicht autorisierten Eingriffen und Mißachtung der einheimischen, hier zur Geltung kommenden Bestimmungen übernimmt die Firma Agilent keinerlei Haftung. Die Controller der Serie Turbo-V 3K-T sind mikroprozessor-gesteuerte Frequenzwandler.

In dieser Gebrauchsanleitung werden Sicherheitshinweise folgendermaßen hervorgehoben:

VORSICHT!

Die Vorsichtshinweise vor bestimmten Prozeduren machen den Bediener darauf aufmerksam, daß bei Nichteinhaltung Schäden an der Anlage entstehen können.

WARNUNG!



Die Warnhinweise lenken die Aufmerksamkeit des Bedieners auf eine bestimmte Prozedur oder Praktik, die bei unkorrekter Ausführung schwere Verletzungen hervorrufen können.

HINWEIS

Die Hinweise enthalten wichtige Informationen, die aus dem Text hervorgehoben werden.

Lagerung

Beim Transport und bei der Lagerung der Controller müssen folgende klimatische Verhältnisse eingehalten werden:

- Temperatur: von -20 °C bis +70 °C
- Relative Luftfeuchtigkeit: 0 – 95 % (nicht kondensierend)

Vor der Installation

Der Controller wird mit einer speziellen Schutzverpackung geliefert. Eventuelle Transportschäden müssen der zuständigen örtlichen Verkaufsstelle gemeldet werden. Beim Auspacken vorsichtig vorgehen, damit der Controller nicht fällt oder Stößen ausgesetzt wird. Das Verpackungsmaterial muß korrekt entsorgt werden. Es ist vollständig recyclebar und entspricht der EG-Richtlinie 85/399 für Umweltschutz.



Abbildung 1 Verpackung der Controller

Alle Agilent-Controller sind werkseitig für eine bestimmte Anschlußspannung ausgelegt:

- Modell 869-9447 für 220 VWs
- Modell 869-9547 für 120 VWs

Sicherstellen, daß die korrekte Spannung gewählt wurde, und das Netzkabel wieder anschließen.

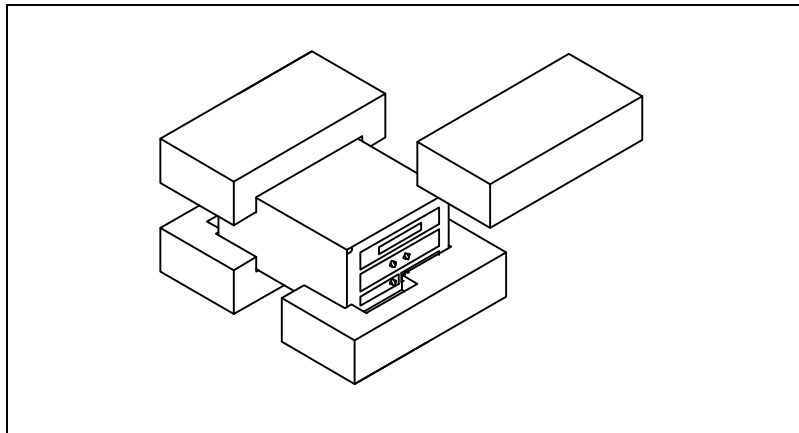
Installation

WARNUNG!



Der Controller wird mit einem Netzkabel geliefert, das 3 Drähte enthält und mit einem den internationalen Normen entsprechenden Stecker ausgerüstet ist. Es sollte immer dieses Netzkabel benutzt werden, das an eine korrekt geerdete Steckdose anzuschließen ist, um Stromentladungen zu vermeiden. Im Inneren des Controllers entstehen hohe Spannungen, die schwere Schäden verursachen und zum Teil lebensgefährlich sein können. Vor jedem Montage- bzw. Wartungseingriff muß deshalb der Netzstecker gezogen werden.

HINWEIS

Der Controller kann auf einen Tisch oder ein Gestell montiert werden. In beiden Fällen muß auf die ungehinderte Zirkulation der Kühlluft im Bereich des Geräts geachtet werden. Der Controller darf nicht in Umgebungen installiert u/o benutzt werden, die Witterungseinflüssen (Regen, Frost, Schnee), Staub und aggressiven Gasen ausgesetzt sind und in denen Explosions- und erhöhte Brandgefahr besteht.

Beim Betrieb müssen folgende Umgebungsbedingungen eingehalten werden:

- Temperatur: von 0 °C bis +40 °C
- Relative Luftfeuchtigkeit: 0 - 95 % (nicht kondensierend).

Für den Anschluß des Controllers an die Pumpe muß das zum Controller gehörende Kabel benutzt werden.

Für weitere Hinweise bezüglich Anschlüsse und Montage des bestellbaren Zubehörs siehe "Technical Information".

Gebrauch

In diesem Kapitel sind die wichtigsten Betriebsvorgänge aufgeführt. Für weitere Hinweise bezüglich Anschlüsse und Montage des bestellbaren Zubehörs siehe Kapitel "Use" im Anhang zu "Technical Information". Vor Benutzung des Controllers sämtliche elektrischen und pneumatischen Anschlüsse ausführen, und die Betriebsanleitung der angeschlossenen Pumpe durchlesen.

WARNUNG!



Steht die Pumpe auf einem Tisch, muß auf den stabilen Stand geachtet werden, da sonst die Gefahr von Personen- und Geräteschäden besteht. Die Pumpe nie einschalten, wenn der Eingangsflansch nicht am System angeschlossen bzw. nicht mit dem Schließflansch abgedeckt ist.

HINWEIS

Der Wiederverschließ-Verbinder J1 muß mit seiner Brücke angeschlossen bleiben, wenn kein externer Anschluß erfolgt. Die Vorvakuumpumpe und die Turbo-V-Pumpe können gleichzeitig eingeschaltet werden.

Steuerungen, Anzeigen und Verbinder des Controllers

Nachstehend werden die Steuertafel des Controllers sowie die Verbindungstafeln beschrieben. Für weitere Einzelheiten siehe "Technical Information".



Abbildung 2 Fronttafel der Controller 869-9447 und 869-9547

1	Taste für die Einstellung des Modus HIGH/LOW SPEED. Sie ist nur aktiv, wenn der Steuermodus auf Fronttafel eingestellt ist. Bei mehrmaligem Drücken geht man taktweise von HIGH SPEED auf LOW SPEED über.
2	START-, STOPP- oder RESET-Taste. Sie ist nur aktiv, wenn der Steuermodus auf der Fronttafel eingestellt ist. Bei einmaligem Drücken wird die Startphase aktiviert. Bei nochmaligem Drücken stoppt die Pumpe. Bei automatischem Pumpenstopp durch Störung muß diese Taste ein erstes Mal zur Controller-Rücksetzung und dann ein zweites Mal zum Neustarten der Pumpe gedrückt werden.
3	Taste für die Anzeige der Parameter "cycle number", "cycle time" und "pump life" und Seriennummer.
4	Taste für die Anzeige der Parameter "pump current", "pump temperature", "pump power" und "rational speed", den ermittelten Flußwert, Gasart und Alarmzustand. Sie ist immer aktiv, unabhängig vom gewählten Betriebsmodus. Bei gemeinsamer, mindestens 2 Sekunden langer Betätigung der Tasten 3 und 4 wird ein Programm aktiviert, mit dem einige Betriebsparameter programmiert werden können.
5	Alphanumerisches Flüssigkristall-Display: Punktmatrix, 2 Zeilen mit 16 Stellen.

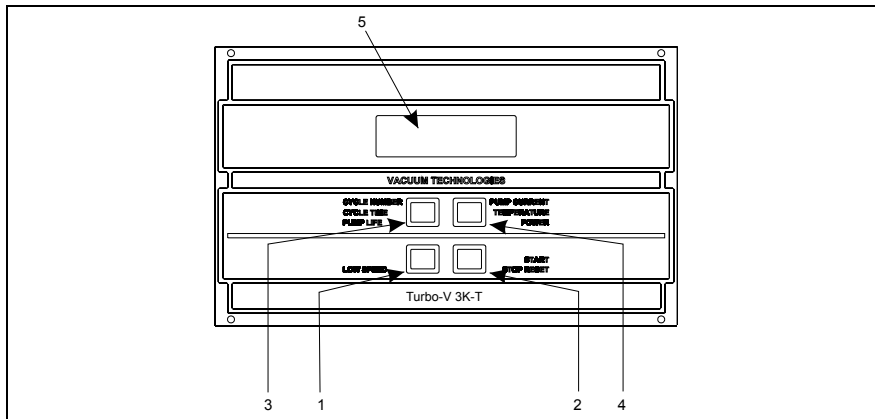

Abbildung 3 Rückseitige Tafel der Controller 869-9447 und 869-9547

1	Eingangsverbinder der logischen Signale (der Kupplungsverbinder wird mit einer Wiederverschließbrücke geliefert).
2	Ausgangsverbinder der logischen und Pumpenstromkontrollsignale, sowie der Ansteuerfrequenzen.
3	Platz für den Verbinder des seriellen Anschlusses RS-232 – RS-485 (Option).
4	Reinigungsverbinder.
5	Versorgungseingangsmodul für den Controller. Umfaßt die Schutzsicherung, den Spannungswandler, die Leistungsanschlußbuchse und den EMC-Filter.
6	Hauptschalter.
7	Erdungsanschluß.
8	Pumpenkabelverbindung

Bedienung

Einschalten des Controllers

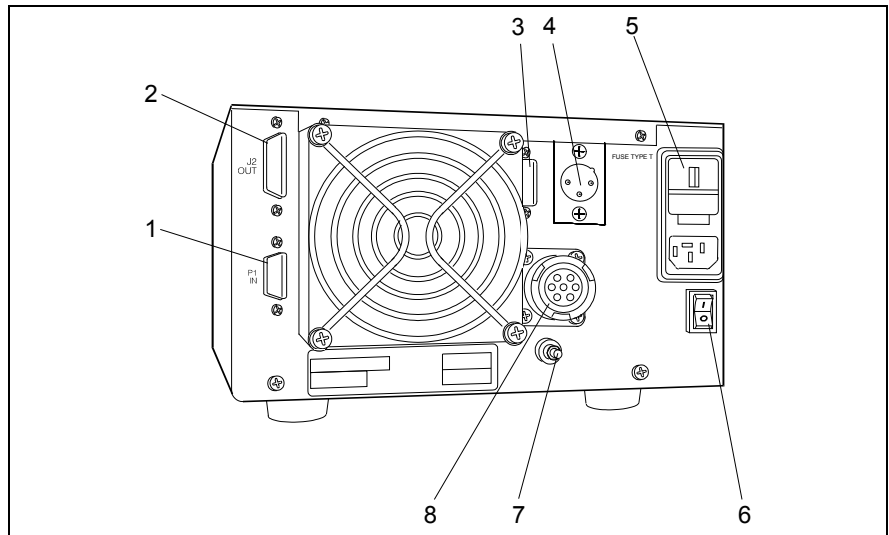
Zum Einschalten des Controllers genügt es, das Netzkabel an die Steckdose anzuschließen und den Leitungsschalter in Position 1 bringen.

Pumpenstart

Zum Starten der Pumpe muß die Taste START an der Fronttafel gedrückt werden.

Pumpenstopp

Zum Stoppen der Pumpe muß die STOPP-Taste an der Fronttafel gedrückt werden.

Wartung

Die Controller der Serie Turbo-V 3K-T sind wartungsfrei. Eventuell erforderliche Eingriffe müssen von dazu befugtem Fachpersonal ausgeführt werden. Bei einem Defekt kann der Agilent-Reparaturdienst bzw. der "Agilent advanced exchange service" in Anspruch genommen werden, der für die Erneuerung defekter Controller sorgt.

WARNUNG!

Vor jedem Eingriff am Controller muß der Netzstecker gezogen werden.



Eine eventuelle Verschrottung muß unter Einhaltung der spezifischen landesüblichen Vorschriften erfolgen.

Entsorgung

Bedeutung des "WEEE" Logos auf den Etiketten. Das folgende Symbol ist in Übereinstimmung mit der EU-Richtlinie WEEE (Waste Electrical and Electronic Equipment) angebracht. Dieses Symbol (**nur in den EU-Ländern gültig**) zeigt an, dass das betreffende Produkt nicht zusammen mit Haushaltsmüll entsorgt werden darf sondern einem speziellen Sammelsystem zugeführt werden muss. Der Endabnehmer sollte daher den Lieferanten des Geräts - d.h. die Muttergesellschaft oder den Wiederverkäufer - kontaktieren, um den Entsorgungsprozess zu starten, nachdem er die Verkaufsbedingungen geprüft hat.

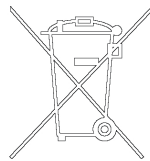

Fehlermeldungen

In einigen Störungsfällen zeigt das Selbstdiagnosesystem des Controllers die in der nachstehenden Tabelle zusammengefaßten Meldungen an.

Tab. 1

Meldung	Beschreibung	Behebung
CHECK CONNECTION TO PUMP	Fehlfunktion der Pumpen-Controller Verbindung.	Sicherstellen, daß das Verbindungskabel zwischen Pumpe und Controller an beiden Seiten korrekt befestigt ist und keine Unterbrechung vorliegt. Die Pumpe durch zweimalige Betätigung der START-Taste neustarten.
PUMP WAITING INTERLOCK	Das Interlock-Signal auf dem Verbinder P1 ist wegen der Kurzschlußunterbrechung zwischen Pin 3 und Pin 8 des Verbinders J1 oder wegen der Öffnung des externen Interlock-Signals aktiv.	Den Kurzschluß zwischen Pin 3 und Pin 8 des Verbinders J1 rücksetzen oder das externe Interlock-Signal schließen.
FAULT: PUMP OVERTEMP.	Die Temperatur des oberen Lagers bzw. der Pumpe hat 60 °C überschritten.	Warten bis die Temperatur unter den Schwellenwert gesunken ist. Die Pumpe durch zweimalige Betätigung der START-Taste neustarten.
FAULT: CONTROLLER OVERTEMPERATURE	Die Temperatur des Controller-Trafos hat 90 °C überschritten.	Warten bis die Temperatur unter den Schwellenwert gesunken ist. Die Pumpe durch zweimalige Betätigung der START-Taste neustarten.

Meldung	Beschreibung	Behebung
FAULT: TOO HIGH LOAD	Während des Normalbetriebs (nach der Startphase) ist die Pumpen stromaufnahme größer als die vorgesehene.	Sicherstellen, daß der Pumpenrotor ungehindert drehen kann. Die Pumpe durch zweimalige Betätigung der START-Taste neustarten.
FAULT: SHORT CIRCUIT	Während des Normalbetriebs (nach der Startphase) erfolgt ein Kurzschluß der Ausgangsverbindung.	Die Verbindung zwischen Pumpe und Controller prüfen. Die Pumpe durch zweimalige Betätigung der START-Taste neustarten.
OVERVOLTAGE	Im Bereich der Kontrollerversorgung ist eine Störung aufgetreten oder der Controller hat ein unechtes Signal empfangen.	Die Taste START zweimal drücken, um die Pumpe wieder anzufahren. Falls die Meldung nochmals auftritt, die Firma Agilent zur Instandsetzung zu Rate ziehen.
FLOW METER ALARM	Alarm hinsichtlich Auswurffluß. Der Flußwert befindet sich für die Dauer von mehr als oder gleich 10 Sekunden auf einem Wert unterhalb der eingestellten Schwelle.	Einwandfreien Betrieb des Gasversorgungskreises überprüfen.

2 **Gebrauchsanleitung** Fehlermeldungen



3 Mode d'emploi

Indications generales	38
Emmagasinage	38
Preparation pour l'installation	39
Installation	40
Utilisation	41
Commandes, Indicateurs et Connecteurs du Contrôleur	42
Procedures d'utilisation	44
Allumage du Contrôleur	44
Mise en marche de la Pompe	44
Arrêt de la Pompe	44
Entretien	44
Mise au rebut	45
Messages d'erreur	46

Traduction de la mode d'emploi originale



Indications générales

Cet appareillage a été conçu en vue d'une utilisation professionnelle. Il est conseillé à l'utilisateur de lire attentivement cette notice d'instructions ainsi que toute autre indication supplémentaire fournie par Agilent, avant d'utiliser l'appareil. Agilent décline par conséquent toute responsabilité en cas d'observation totale ou partielle des instructions données, d'utilisation incorrecte de la part d'un personnel non formé, d'opérations non autorisées ou d'un emploi contraire aux réglementations nationales spécifiques. Les contrôleurs de la série Turbo-V 3K-T sont des convertisseurs de fréquence, contrôlés par un microprocesseur, réalisés avec des éléments à l'état solide et ayant des capacités d'autodiagnostic et d'autoprotection.

Cette notice utilise les signes conventionnels suivants:

ATTENTION!

Les messages d'attention apparaissent avant certaines procédures qui, si elles ne sont pas observées, pourraient endommager sérieusement l'appareillage.

AVERTISSEMENT!



Les messages d'avertissement attirent l'attention de l'opérateur sur une procédure ou une manœuvre spéciale qui, si elle n'est pas effectuée correctement, risque de provoquer de graves lésions..

NOTE

Les notes contiennent des renseignements importants, isolés du texte.

Emmagasinage

Pendant le transport et l'emmagasinage des contrôleurs, il faudra veiller à respecter les conditions environnementales suivantes:

- température: de - 20 °C à + 70 °C
- humidité relative: de 0% à 95 % (non condensante).

Préparation pour l'installation

Le contrôleur est fourni dans un emballage de protection spécial; si l'on constate des marques de dommages pouvant s'être produits pendant le transport, contacter aussitôt le bureau de vente local.

Pendant l'opération d'ouverture de l'emballage, veiller tout particulièrement à ne pas laisser tomber le contrôleur et à ne lui faire subir aucun choc. Ne pas jeter l'emballage dans la nature. Le matériel est entièrement recyclable et il est conforme aux directives CEE 85/399 en matière de protection de l'environnement.

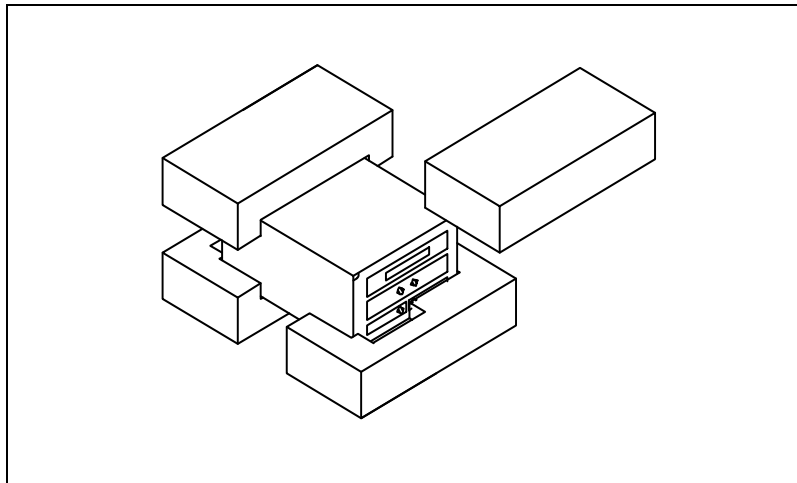

Figure 1 Emballage des contrôleurs

Chaque contrôleur est fourni par Agilent pré-équipé pour une certaine tension d'alimentation:

- le modèle 869-9447 pour 220 Vca
- le modèle 869-9547 pour 120 Vca.

S'assurer que la tension correcte a été sélectionnée, puis reconnecter le câble d'alimentation.

Installation

AVERTISSEMENT!



Les contrôleur est doté d'un câble d'alimentation à trois fils avec une fiche du type approuvé au niveau international. Utiliser toujours ce câble d'alimentation et introduire la fiche dans une prise pourvue d'un branchement approprié à la masse, afin d'éviter toute décharge électrique. A l'intérieur du contrôleur se développent de hautes tensions qui peuvent causer de graves dommages et même la mort. Avant d'effectuer toute opération d'installation ou d'entretien du contrôleur, le débrancher de la prise d'alimentation.

NOTE

Le contrôleur peut être installé sur une table ou à l'intérieur d'un rack prévu à cet effet. Il est en tout cas nécessaire que l'air de refroidissement puisse circuler librement à l'intérieur de l'appareil. Ne pas installer et/ou utiliser le contrôleur dans des milieux exposés à des agents atmosphériques (pluie, gel, neige), à des poussières, à des gaz de combat ainsi que dans des milieux explosifs ou à risque élevé d'incendie.

Pendant le fonctionnement, il est nécessaire de respecter les conditions environnementales suivantes:

- température: de 0 °C à + 40 °C
- humidité relative: de 0 % à 95 % (non condensante).

Pour la connexion du contrôleur à la pompe correspondante, utiliser le câble du contrôleur prévu à cet effet.

Pour les autres connexions et pour l'installation des accessoires en option, voir la section "Technical Information".

Utilisation

Dans ce paragraphe, on indique les principales pro-cédures opérationnelles. Pour tous autres détails et pour les procédures concernant des connexions ou des éléments en option, se reporter au paragraphe "Use" de l'appendice "Technical Information". Avant d'utiliser le contrôleur, effectuer toutes les connexions électriques et pneumatiques et se référer à la notice de la pompe connectée.

AVERTISSEMENT!



Pour éviter tous dommages aux personnes et à l'appareil, si la pompe est placée sur une table, s'assurer que cette dernière est stable. Ne jamais faire fonctionner la pompe si la bride d'entrée n'est pas connectée au système ou si elle n'est pas fermée à l'aide de la bride de serrage.

NOTE

Laisser le connecteur de réenclenchement J1 connecté à sa barrette s'il n'est procédé à aucune connexion extérieure. La pompe à pré-vide et la pompe Turbo-V peuvent être mises en marche simultanément.

Commandes, Indicateurs et Connecteurs du Contrôleur

On présente ci-dessous le tableau de commande du Contrôleur ainsi que les tableaux d'interconnexion. Pour de plus amples détails, se reporter à la section "Technical Information".

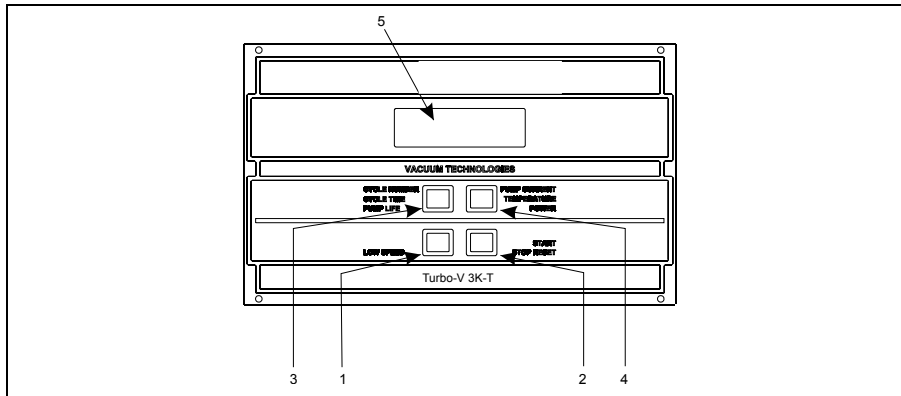

Figure 2 Tableau frontal des Contrôleurs 869-9447 et 869-9547

- 1 Bouton de sélection du mode HIGH/LOW SPEED. Il n'est actif que lorsque le mode de commande est sélectionné depuis le tableau frontal. La pression répétée de ce bouton permet de passer cycliquement de HIGH SPEED à LOW SPEED
- 2 Interrupteur envoyant les commandes de START, STOP ou RESET. Il n'est actif que lorsque le mode de commande est sélectionné depuis le tableau frontal. Une première pression de l'interrupteur active la phase de mise en marche; une deuxième pression provoque l'arrêt de la pompe. Si la pompe s'est arrêtée automatiquement à cause d'une panne, il faut presser cet interrupteur une première fois pour effectuer la mise à zéro du contrôleur et une deuxième fois pour remettre la pompe en marche.
- 3 Interrupteur rappelant sur l'afficheur les paramètres de cycle number, cycle time et pump life et numéro de série.
- 4 Bouton permettant de rappeler sur l'afficheur les paramètres de pump current, pump temperature, pump power et rotational speed, valeur du flux relevée, type de gaz et état de l'alarme. Il est toujours actif indépendamment du type de mode de fonctionnement choisi. En pressant simultanément les boutons 3 et 4 pendant 2 secondes au moins, on active un programme avec lequel il est possible de sélectionner certains paramètres opérationnels.
- 5 Ecran alphanumérique à cristaux liquides: matrice de points, 2 lignes x 16 caractères.

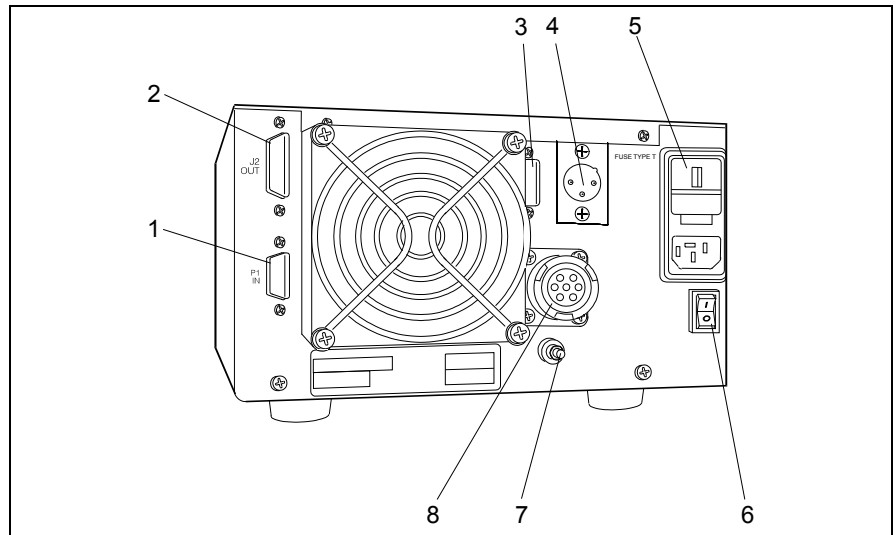

Figure 3 Tableau arrière des Contrôleurs 869-9447 et 869-9547

1	Connecteur d'entrée des signaux logiques (le connecteur d'enclenchement est doté de la barrette de réenclenchement spéciale).
2	Connecteur de sortie des signaux logiques et de vérification du courant de la pompe et de la fréquence d'excitation.
3	Emplacement prévu pour le connecteur de la porte de communication série RS-232 – RS485 (fournie en option).
4	Purge-vent connector.
5	Connecteur pour le câble d'alimentation du heater jacket.
6	Interrupteur de ligne.
7	Connexion de mise à la terre.
8	Connecteur pour le câble de la pompe.

Procédures d'utilisation

Allumage du Contrôleur

Pour allumer le contrôleur, il suffit d'introduire le câble d'alimentation dans la prise du réseau et placer l'interrupteur sur la position 1.

Mise en marche de la Pompe

Pour mettre la pompe en marche, presser l'interrupteur START du tableau frontal.

Arrêt de la Pompe

Pour arrêter la pompe, presser l'interrupteur STOP du tableau frontal.

Entretien

Les contrôleurs de la série Turbo-V 3K-T n'exigent aucun entretien. Toute opération doit être effectuée par un personnel agréé.

En cas de panne, il est possible de s'adresser au Service de réparation Agilent ou bien au "Agilent advance exchange service" qui permet d'obtenir un contrôleur régénéré à la place du contrôleur détraqué.

AVERTISSEMENT!

Avant d'effectuer toute opération sur le contrôleur, dé-brancher le câble d'alimentation.

En cas de mise au rebut d'un contrôleur, procéder à son élimination conformément aux réglementations nationales en la matière.

Mise au rebut

Signification du logo "WEEE" figurant sur les étiquettes. Le symbole ci-dessous est appliqué conformément à la directive CE nommée "WEEE". Ce symbole (**unique-ment valide pour les pays de la Communauté euro-péenne**) indique que le produit sur lequel il est appliqué NE doit PAS être mis au rebut avec les ordures ménagères ou les déchets industriels ordinaires, mais passer par un système de collecte sélective. Après avoir vérifié les termes et conditions du contrat de vente, l'utilisateur final est donc prié de contacter le fournisseur du dispositif, maison mère ou revendeur, pour mettre en œuvre le processus de collecte et mise au rebut.

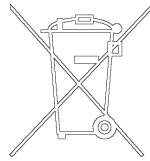

Messages d'erreur

Dans certains cas de panne, l'ensemble de circuits d'autodiagnostic du contrôleur présente certains messages d'erreur indiqués dans le tableau ci-dessous.

Tab. 1

Message	Description	Intervention
CHECK CONNECTION TO PUMP	Disfonctionnement de la connexion entre la pompe et le contrôleur.	S'assurer que le câble de connexion entre la pompe et le contrôleur est bien fixé aux deux extrémités et qu'il n'est pas coupé. Presser deux fois l'interrupteur START pour réactiver la pompe.
PUMP WAITING INTERLOCK	Le signal d'interlock situé sur le connecteur P1 est actif à cause de la coupure du court-circuit entre le pin 3 et le pin 8 du connecteur J1 ou à cause de l'ouverture du signal d'interlock extérieur.	Rétablir le court-circuit entre le pin 3 et le pin 8 du connecteur J1 ou fermer le signal d'interlock extérieur.
FAULT: PUMP OVERTEMP.	La température du palier supérieur de la pompe a dépassé 60 °C.	Attendre que la température retourne au-dessous du seuil. Presser deux fois l'interrupteur START pour remettre la pompe en marche.
FAULT: CONTROLLER OVERTEMPERATURE	La température du transformateur du contrôleur a dépassé 90 °C.	Attendre que la température retourne au-dessous du seuil. Presser deux fois l'interrupteur START pour remettre la pompe en marche.

Message	Description	Intervention
FAULT: TOO HIGH LOAD	Au cours du fonctionnement normal, le courant consommé par la pompe est plus grand que celui qui a été programmé.	S'assurer que le rotor de la pompe a la possibilité de tourner librement. Presser deux fois l'interrupteur START pour remettre la pompe en marche.
FAULT: SHORT CIRCUIT	Au cour du fonctionnement normal (après la phase de mise en marche), la connexion de sortie est en court-circuit.	Vérifier les connexions entre la pompe et le contrôleur. Presser deux fois l'interrupteur START pour remettre la pompe en marche.
OVERVOLTAGE	Un défaut s'est avéré dans la section d'alimentation du contrôleur, ou le contrôleur a reçu un faux signal.	Appuyer deux fois sur le bouton START pour faire redémarrer la pompe. Si le message est réaffiché vous adresser à la société Agilent pour l'entretien.
FLOW METER ALARM	Alarme concernant le flux de purge. La valeur du flux est restée au dessous du seuil défini pour une période supérieure ou égale à 10 secondes.	Vérifier le bon fonctionnement du circuit d'alimentation du gaz.

3 Mode d'emploi

Messages d'erreur

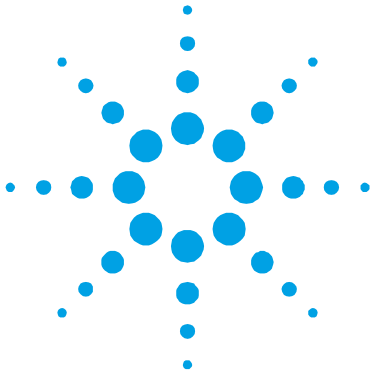

4 Manual de instrucciones

Información general	50
Almacenamiento	50
Preparación para la instalación	51
Instalación	52
Uso	52
Mandos, Indicadores y Conectores del Controler	54
Procedimientos de uso	56
Encendido del controler	56
Puesta en marcha de la Bomba	56
Parada de la Bomba	56
Mantenimiento	56
Eliminación	57
Mensajes de error	58

Traducción de las instrucciones originales



Información general

Este equipo se ha concebido para un uso profesional. El usuario deberá leer atentamente el presente manual de instrucciones y cualquier otra información suplementaria facilitada por Agilent antes de utilizar el equipo. Agilent se considera libre de cualquier responsabilidad debida al incumplimiento total o parcial de las instrucciones, al uso poco apropiado por parte de personal sin formación, a las operaciones no autorizadas o al uso que no cumpla con las normas nacionales específicas. Los controlers de la serie Turbo-V 3K-T son convertidores de frecuencia, controlados por un microprocesador, realizados con componentes en estado sólido y con capacidad de autodiagnos y autoprotección.

Este manual utiliza los símbolos convencionales siguientes:

¡ATENCIÓN!

Los mensajes de atención se visualizan antes de procedimientos que, al no respetarse, podrían provocar daños al equipo.

¡ADVERTENCIA!



Los mensajes de advertencia atraen la atención del operador sobre un procedimiento o una operación específica que, al no realizarse correctamente, podría provocar graves lesiones personales.

NOTA

Las notas contienen información importante extraída del texto.

Almacenamiento

Durante el transporte y el almacenamiento de los controlers se deberá cumplir con las condiciones ambientales siguientes:

- temperatura: de -20 °C a +70 °C
- humedad relativa: 0 – 95 % (no condensadora)

Preparación para la instalación

El controler se suministra en un embalaje de protección especial; si se observan señales de daños, que podrían haberse producido durante el transporte, ponerse en contacto con la oficina de venta más cercana.

Durante la operación de desembalaje, prestar una atención especial a no dejar caer el controler y evitarle golpes. No dispersar el embalaje en el medio ambiente. El material es totalmente reciclable y cumple con la directiva CEE 85/399 para la preservación del medio ambiente.



Figura 1 Embalaje de los Controlers

Cada controler llega de Agilent preparado para una cierta tensión de alimentación:

- el modelo 869-9447 por 220 Vac
- el modelo 869-9547 por 120 Vac

Comprobar que se ha seleccionado la tensión correcta y luego volver a conectar el cable de alimentación.

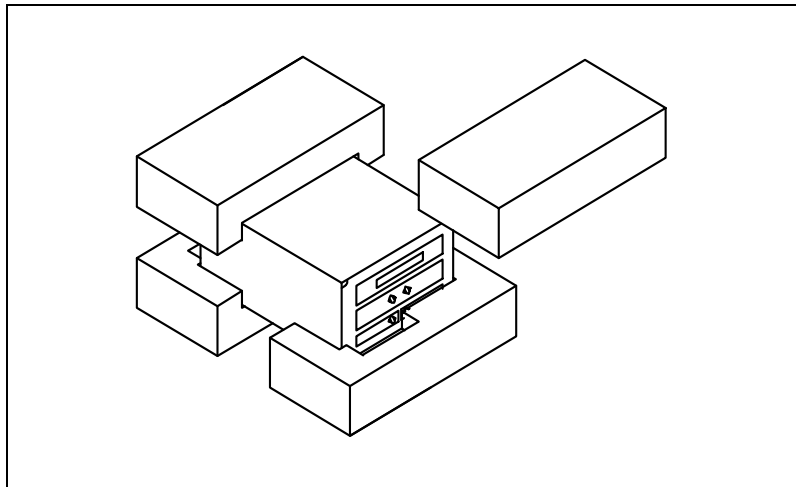
Instalación

¡ADVERTENCIA!



El controler va dotado de un cable de alimentación de tres hilos con una clavija de tipo aprobado a nivel internacional. Utilizar siempre este cable de alimentación e introducir la clavija en un enchufe con una conexión de masa adecuada para evitar descargas eléctricas. Dentro del controler se desarrollan altas tensiones que pueden causar graves daños o la muerte. Antes de efectuar cualquier operación de instalación o mantenimiento del controler desconectarlo del enchufe de alimentación.

NOTA

El controler puede instalarse en una mesa o dentro de un rack específico. En cualquier caso, es necesario que el aire de refrigeración pueda circular libremente alrededor del aparato. No instalar y/o utilizar el controler en ambientes expuestos a agentes atmosféricos (lluvia, hielo y nieve), polvos, gases agresivos, en ambientes explosivos o con alto riesgo de incendio.

Durante el funcionamiento es necesario que se respeten las condiciones ambientales siguientes:

- temperatura: de 0 °C a + 40 °C
- humedad relativa: 0 – 95 % (no condensadora).

Para la conexión del controler con la bomba correspondiente utilizar el cable específico del controler.

Para otras conexiones y la instalación de los accesorios opcionales, véase la sección “Technical Information”.

Uso

En este apartado se citan los procedimientos operativos principales. Para más detalles y para procedimientos que impliquen conexiones u opcionales especiales, les remitimos al apartado “Use” del anexo “Technical Informations”.

Antes de usar el controler efectuar todas las conexiones eléctricas y neumáticas y consultar el manual de la bomba conectada.

¡ADVERTENCIA!



Para evitar lesiones a las personas y al aparato, si la bomba está apoyada sobre una mesa cerciorarse que es estable. No poner en marcha nunca la bomba si la brida de entrada no está conectada al sistema o no está cerrada con la brida de cierre.

NOTA

El conector di cierre J1 ha de dejarse conectado con su conector puente si no se efectúa ninguna conexión exterior. La bomba pre-vacío y la bomba Turbo-V pueden encenderse simultáneamente.

Mandos, Indicadores y Conectores del Controler

A continuación se ilustran el panel de mando del controler y los paneles de interconexión. Para más detalles consultar la sección “Technical Information”.



Figura 2 Panel frontal del controler 869-9447 y 869-9547

1	Pulsador para la selección del modo HIGH/LOW SPEED. Está activado sólo cuando está seleccionado el modo de mando del panel frontal. Apretando el pulsador varias veces, se pasa ciclicamente de HIGH SPEED a LOW SPEED.
2	Pulsador para enviar los mandos de START, STOP o RESET. Está activo sólo cuando se selecciona el modo de mando del panel frontal. Apretándolo una vez se activa la fase de puesta en marcha; apretándolo otra vez se para la bomba. Si la bomba se ha parado automáticamente a causa de una avería, hay que apretar este pulsador primero una vez para efectuar el reset del controler y la segunda vez para volver a poner en marcha la bomba.
3	Pulsador para que aparezcan en el display los parámetros cycle number, cycle time y pump life y número serial.
4	Pulsador para que aparezcan en el display los parámetros pump current, pump temperature, pump power y rotational speed, valor del flujo tomado, tipo de gas y estado de la alarma. Está siempre activado independientemente del modo de funcionamiento elegido. Apretando juntos los pulsadores 3 y 4 durante 2 segundos por lo menos, se activa un programa con el cual se pueden seleccionar algunos parámetros operativos.
5	Display alfanumérico de cristales líquidos: matriz de puntos, 2 líneas x 16 caracteres.

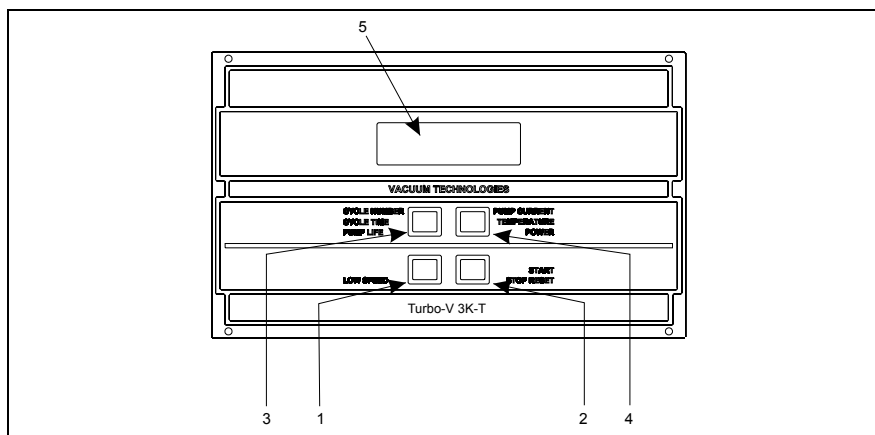

Figura 3 Panel trasero del controlador 869-9447 y 869-9547

1	Conector de entrada de las señales lógicas (el conector de acoplamiento se suministra con el conector puente específico de cierre).
2	Conector de salida de las señales lógicas y de comprobación de la corriente de la bomba.
3	Alojamiento previsto para el conector del puerto de comunicación serie RS-232 - RS-485 (suministrada como opción).
4	Conector de purga.
5	Módulo de entrada de la alimentación para el controlador. Comprende el fusible de protección, el cambiador de tensión, la toma de alimentación de potencia y el filtro EMC.
6	Interruptor de línea.
7	Conexión de tierra.
8	Conector del cable de la bomba.

Procedimientos de uso

Encendido del controler

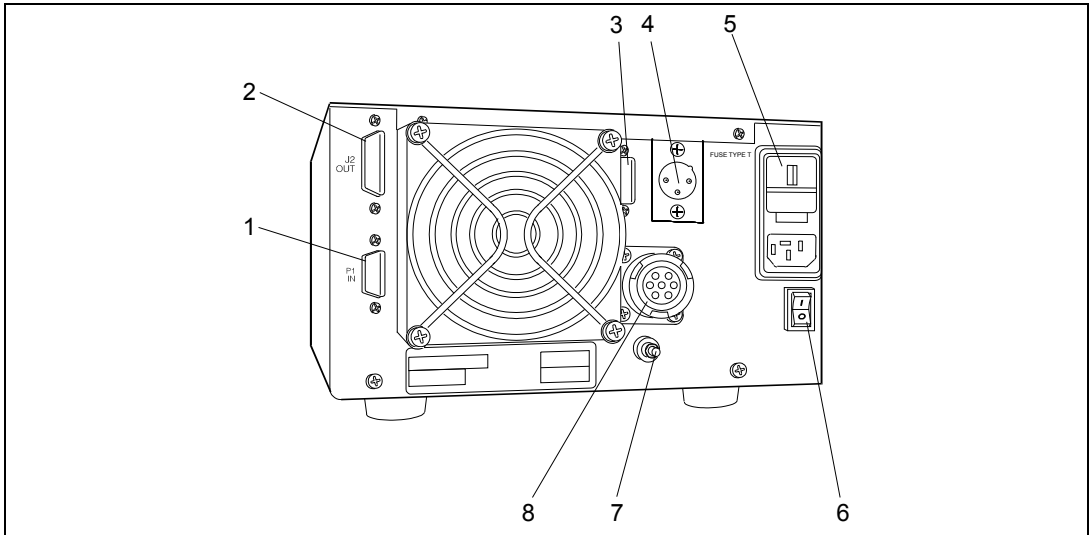
Para encender el controler es suficiente introducir el cable de alimentación en la toma de red y colocar el interruptor de línea en posición 1.

Puesta en marcha de la Bomba

Para poner en marcha la bomba hay que apretar el pulsador START del panel frontal.

Parada de la Bomba

Para detener la bomba hay que apretar el pulsador STOP del panel frontal.

Mantenimiento

Los controlers de la serie Turbo-V 3K-T no necesitan ningún mantenimiento. Cualquier operación ha de ser efectuada por personal autorizado. En caso de avería es posible utilizar el servicio de reparación Agilent o del “Agilent advance exchange service”, que permite obtener un controler regenerado en vez del averiado.

¡ADVERTENCIA!

Antes de efectuar cualquier operación en el controler desenchufar el cable de alimentación.



En caso de que un controler se tenga que desguazar, efectuar su eliminación respetando las normas nacionales específicas.

Eliminación

Significado del logotipo "WEEE" presente en las etiquetas. El símbolo que se indica a continuación, es aplicado en observancia de la directiva CE denominada "WEEE". Este símbolo (**válido sólo para los países miembros de la Comunidad Europea**) indica que el producto sobre el cual ha sido aplicado, NO debe ser eliminado junto con los residuos comunes sean éstos domésticos o industriales, y que, por el contrario, deberá ser sometido a un procedimiento de recogida diferenciada. Por lo tanto, se invita al usuario final, a ponerse en contacto con el proveedor del dispositivo, tanto si éste es la casa fabricante o un distribuidor, para poder proveer a la recogida y eliminación del producto, después de haber efectuado una verificación de los términos y condiciones contractuales de venta.

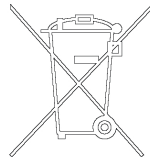

Mensajes de error

En algunos casos de avería los circuitos de autodiagnos del controler presenta algunos mensajes de error detallados en la tabla siguiente.

Tab. 1

Mensaje	Descripción	Acción correctiva
CHECK CONNECTION TO PUMP	Mal funcionamiento en la conexión entre la bomba y el Controler.	Comprobar que el cable de conexión entra en la bomba y el controler está bien fijado por ambos extremos y no está interrumpido. Apretar dos veces el pulsador START para volver a poner en marcha la bomba.
PUMP WAITING INTERLOCK	Está activa la señal de interlock presente en el conector P1 a causa de la interrupción del cortocircuito entre el pin 3 y el pin 8 del conector J1, o a causa de la apertura de la señal de interlock externo.	Eliminar el cortocircuito entre el pin 3 y el pin 8 del conector J1, o cerrar la señal de interlock exterior.
FAULT: PUMP OVERTEMP.	La temperatura del rodamiento superior de la bomba ha superado los 60 °C.	Esperar a que la temperatura vuelva por debajo del umbral. Apretar dos veces el pulsador START para volver a poner en marcha la bomba.
FAULT: CONTROLLER OVERTEMPERATURE	La temperatura del transformador del controler ha superado los 90 °C.	Esperar a que la temperatura vuelva por debajo del umbral. Apretar dos veces el pulsador START para volver a poner en marcha la bomba.

Mensaje	Descripción	Acción correctiva
FAULT: TOO HIGH LOAD	Durante el funcionamiento normal (tras la fase de puesta en marcha) la corriente absorbida por la bomba es superior a la programada.	Comprobar que el rotor de la bomba tiene la posibilidad de girar libremente. Apretar dos veces el pulsador START para volver a poner en marcha la bomba.
FAULT: SHORT CIRCUIT	Durante el funcionamiento normal (tras la fase de puesta en marcha) la conexión de salida está en cortocircuito.	Comprobar las conexiones entre la bomba y el controler. Apretar dos veces el pulsador START para volver a poner en marcha la bomba.
OVERVOLTAGE	Ha ocurrido una avería en la sección de alimentación del controler, o el controler recibió una señal espuria.	Apretar dos veces el pulsador START para volver a poner en marcha la bomba. En caso el mensaje vuelva a aparecer, llamar a Agilent para la manutención.
FLOW METER ALARM	Alarma concerniente al flujo de limpieza (purge). El valor del flujo se ha quedado a un valor inferior del limen impostado durante un tiempo mayor o igual de 10 segundos.	Controlar el correcto funcionamiento del circuito de alimentación del gas.

4 Manual de instrucciones

Mensajes de error



5

Manual de Instruções

Informações gerais	62
Armazenagem	62
Preparação para a instalação	63
Instalação	64
Utilização	65
Comandos, Indicadores e Conectores do Controller	66
Procedimentos de uso	68
Acendimento do Controller	68
Activação da bomba	68
Paragem da bomba	68
Manutenção	68
Eliminação	69
Mensagens de erro	70

Tradução das instruções originais



Informações gerais

Esta aparelhagem destina-se ao uso profissional. O utilizador deve ler atentamente o presente manual de instruções e todas as informações adicionais fornecidas pela Agilent antes de utilizar a aparelhagem. A Agilent não se responsabiliza pela inobservância total ou parcial das instruções, pelo uso indevido por parte de pessoas não treinadas, por operações não autorizadas ou pelo uso contrário às normas nacionais específicas. Os controllers da série Turbo-V 3K-T são conversores de frequência, controlados por um microprocessador, realizados com componentes em estado sólido e com capacidade de autodiagnóstico e autoprotecção.

Este manual utiliza as seguintes convenções:

CUIDADO!

As mensagens de cuidado são visualizadas antes de procedimentos que, se não observados, podem causar danos à aparelhagem.

ATENÇÃO!



As mensagens de atenção chamam a atenção do operador para um procedimento ou uma prática específica que, se não efectuada correctamente, pode provocar graves lesões pessoais.

NOTA

As notas contêm informações importantes destacadas do texto.

Armazenagem

Durante o transporte e a armazenagem dos controllers, devem ser satisfeitas as seguintes condições ambientais:

- temperatura: de -20 °C a + 70 °C
- humidade relativa: 0 – 95 % (não condensante)

Preparação para a instalação

O controller é fornecido numa embalagem protectora especial; se apresentar sinais de danos, que poderiam verificar-se durante o transporte, entrar em contacto com o escritório de vendas local.

Durante a retirada da embalagem, tomar muito cuidado para não deixar cair o controller e para não submetê-lo a choques. Não depositar a embalagem no meio ambiente. O material é completamente reciclável e responde à directriz CEE 85/399 para a protecção do meio ambiente.



Figura 1 Embalagem dos Controllers

Cada controller chega à Agilent predisposto para uma determinada tensão de alimentação:

- o modelo 869-9447 para 220 Vac
- o modelo 869-9547 para 120 Vac

Verificar se foi seleccionada a tensão correcta e, a seguir, ligar novamente o cabo de alimentação.

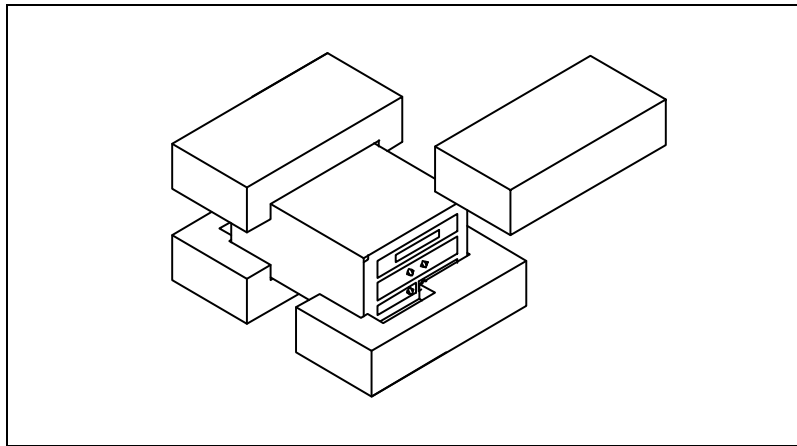
Instalação

ATENÇÃO!



O controller é fornecido com um cabo de alimentação de três fios com uma tomada de tipo aprovado a nível internacional. Utilizar sempre este cabo de alimentação e ligar a tomada à rede com uma ligação de massa adequada, para evitar descargas eléctricas. No interior do controller desen envolvem-se altas tensões que podem provocar graves danos ou a morte. Antes de efectuar qualquer operação de instalação ou manutenção do controller, desligar a tomada de alimentação.

NOTA

O controller pode ser instalado numa mesa ou no interior de um rack específico. Em todo caso, é necessário que o ar de refrigeração possa circular livremente ao redor da aparelhagem. Não instalar e/ou utilizar o controller em ambientes expostos a agentes atmosféricos (chuva, gelo, neve), poeiras, gases agressivos ou em ambientes com perigo de explosão ou com elevado risco de incêndio.

Durante o funcionamento é necessário que sejam respeitadas as seguintes condições ambientais:

- temperatura: de 0 °C a + 40 °C
- humidade relativa: 0 – 95 % (não condensante).

Para a ligação do controller à respectiva bomba, utilizar o cabo específico do próprio controller.

Para as outras ligações e a instalação dos acessórios opcionais, ver a secção "Technical Information".

Utilização

Neste parágrafo são descritos os principais procedimentos operativos. Para maiores detalhes e para procedimentos que envolvem ligações ou peças opcionais, consultar o parágrafo "Use" do apêndice "Technical Information". Antes de usar o controller, efectuar todas as ligações eléctricas e pneumáticas e consultar o manual da bomba ligada.

ATENÇÃO!



Para evitar danos às pessoas e à aparelhagem, caso a bomba esteja apoiada numa mesa, certificar-se que esteja estável. Nunca activar a bomba se o flange de entrada não estiver ligado ao sistema ou não estiver fechado com o flange de fecho.

NOTA

O conector de fecho J1 deve permanecer ligado à sua ponte se não é efectuada nenhuma ligação externa. A bomba de pré-vácuo e a bomba Turbo-V podem ser ligadas simultaneamente.

Comandos, Indicadores e Conectores do Controller

A seguir, estão ilustrados o painel de comando do Controller e os painéis de interconexão. Para maiores detalhes, consultar a secção "Technical Information".



Figura 2 Painel frontal do Controller 869-9447 e 869-9547

- | | |
|---|--|
| 1 | Botão para a selecção do modo HIGH/LOW SPEED. Está activo só quando é seleccionado o modo de comando pelo painel frontal. Premendo-o repetidamente, passa-se ciclicamente de HIGH SPEED para LOW SPEED. |
| 2 | Botão para enviar os comandos de START, STOP ou RESET. Está activo só quando é seleccionado o modo de comando pelo painel frontal. Premendo-o uma vez activa-se a fase de accionamento; premendo-o novamente a bomba pára. Se a bomba parou automaticamente devido a um defeito, é necessário premer este botão uma vez para executar o reset do controller e uma segunda vez para reactivar a bomba. |
| 3 | Botão para visualizar no mostrador os parâmetros de cycle number, cycle time e pump life e número de série. |
| 4 | Botão para visualizar no mostrador os parâmetros de pump current, pump temperature, pump power, rotational speed, valor do fluxo detectado, tipo de gás e estado de alarme. Está sempre activo, independentemente do modo de funcionamento escolhido. Premendo ao mesmo tempo os botões 3 e 4 por, no mínimo, 2 segundos, é activado um programa com o qual é possível programar alguns parâmetros operativos. |
| 5 | Mostrador alfanumérico a cristais líquidos: matriz por pontos, 2 linhas x 16 caracteres. |

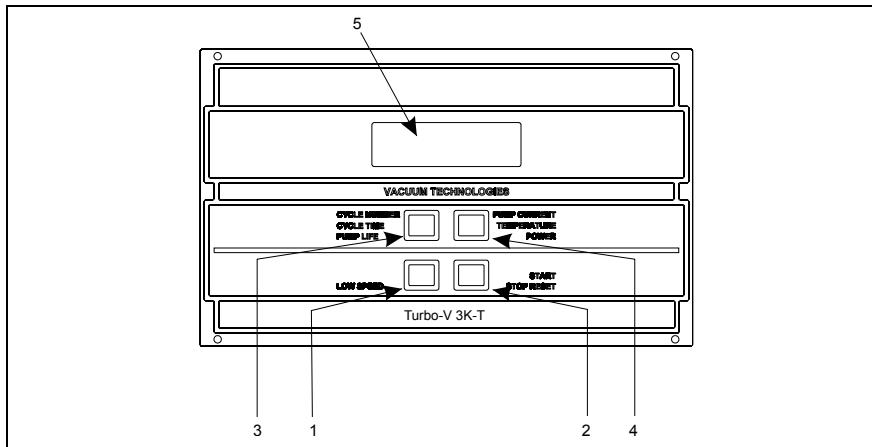

Figura 3 Painel posterior dos Controllers 869-9447 e 869-9547

1	Conector de entrada dos sinais lógicos (o conector de acoplamento é fornecido com ponte específica de fecho).
2	Conector de saída dos sinais lógicos e de verificação da corrente da bomba.
3	Vão previsto para o conector da porta de comunicação serial RS-232 – RS-485.
4	Conector de evacuação de ar.
5	Módulo de entrada da alimentação para o Controller. Compreende o fusível de protecção, o transformador de tensão, a tomada de alimentação de potência e o filtro EMC.
6	Interruptor de linha.
7	Ligação à terra.
8	Conector do cabo da bomba.

Procedimentos de uso

Acendimento do Controller

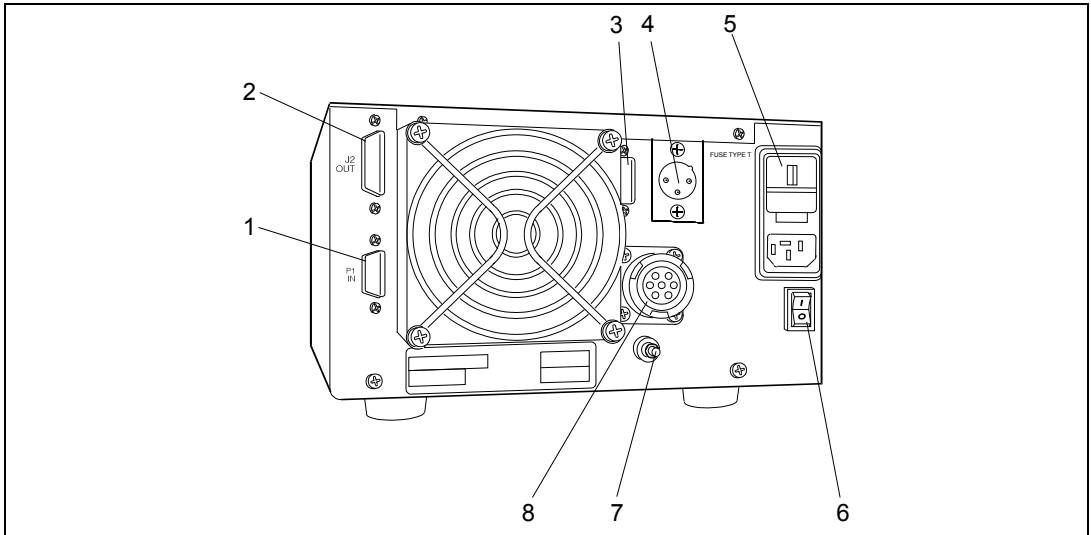
Para ligar o controller, é suficiente inserir o cabo de alimentação na tomada de rede e coloque o interruptor de linha em posição 1.

Activação da bomba

Para activar a bomba, é necessário premer o botão START do painel frontal.

Paragem da bomba

Para parar a bomba, é necessário premer o botão STOP do painel frontal.

Manutenção

Os controllers da série Turbo-V 3K-T não requerem qualquer manutenção. Todas as operações devem ser efectuadas por pessoal autorizado.

Em caso de defeito é possível utilizar o serviço de reparação Agilent ou o "Agilent advanced exchange service", que permite obter um controller regenerado que substitua o controller com defeito.

ATENÇÃO!

As Antes de efectuar qualquer operação no controller, desligar o cabo de alimentação.



Caso um controller deva ser destruído, proceder à sua eliminação respeitando as normas nacionais específicas.

Eliminação

Significado do logótipo "WEEE" presente nos rótulos. O símbolo abaixo indicado é aplicado de acordo com a directiva CE denominada "WEEE". Este **símbolo (válido apenas para os países da Comunidade Europeia)** indica que o produto no qual está aplicado NÃO deve ser eliminado juntamente com os resíduos domésticos ou industriais comuns, mas deve ser dirigido a um sistema de recolha diferenciada. Portanto, convidamos o utilizador final a contactar o fornecedor do dispositivo, seja este o fabricante ou um revendedor, para encaminhar o processo de recolha e eliminação, após a oportuna verificação dos termos e condições do contrato de venda.

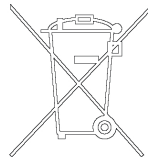

Mensagens de erro

Em alguns casos de defeitos, os circuitos de autodiagnóstico do controller apresentam mensagens de erro relacionadas na tabela abaixo.

Tab. 1

Mensagem	Descrição	Acção correctiva
CHECK CONNECTION TO PUMP	Mau funcionamento na ligação entre a bomba e o controller.	Verificar se o cabo de ligação entre a bomba e o controller está bem fixado em ambas as extremidades e não está interrompido. Premer duas vezes o botão START para reactivar a bomba.
PUMP WAITING INTERLOCK	É activado o sinal de interlock existente no conector P1 devido à interrupção do curto circuito entre o pin 3 e o pin 8 do conector J1 ou devido à abertura do sinal de interlock externo.	Restabelecer o curto circuito entre o pin 3 e o pin 8 do conector J1 ou fechar o sinal de interlock externo.
FAULT: PUMP OVERTEMP.	A temperatura do rolamento superior da bomba superou os 60 °C.	Aguardar até que a temperatura regresse dentro do limite estabelecido. Premer duas vezes o botão START para reactivar a bomba.
FAULT: CONTROLLER OVERTEMPERATURE	A temperatura do transformador do controller superou os 90 °C.	Aguardar até que a temperatura volte ao limite estabelecido. Premer duas vezes o botão START para reactivar a bomba.

Mensagem	Descrição	Acção correctiva
FAULT: TOO HIGH LOAD	Durante o funcionamento normal a corrente absorvida pela bomba é maior do que a programada.	Verificar se o rotor da bomba pode rodar livremente. Premer duas vezes o botão START para reactivar a bomba.
FAULT: SHORT CIRCUIT	Durante o funcionamento normal (após a fase de accionamento) a conexão de saída está em curto circuito.	Verificar as ligações entre a bomba e o controller. Premer duas vezes o botão START para reactivar a bomba.
OVERVOLTAGE	Verificou-se um defeito na secção de alimentação do controller, ou o controller recebeu um sinal falso	Premer duas vezes o botão START para reactivar a bomba. Se a mensagem se reapresenta, dirigir-se à Agilent para a manutenção.
FLOW METER ALARM	Alarme relativo ao fluxo de descarga. O valor do fluxo permaneceu num valor inferior ao limite estabelecido, durante um tempo maior ou igual a 10 segundos.	Verificar se o circuito de alimentação do gás funciona correctamente.

5 Manual de Instruções

Mensagens de erro

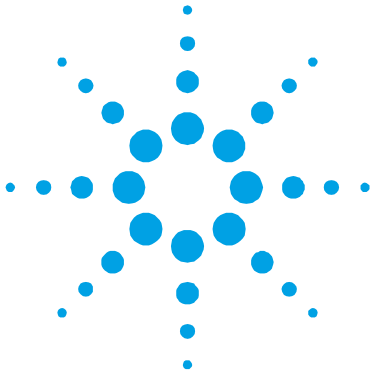

6 Bedrijfshandleiding

Algemene informatie	74
Opslag	74
Vorbereiding voor installatie	75
Installatie	76
Gebruik	77
Bedieningsorganen, Controlelampjes en Connectoren van de Controller	78
Gebruiksprocedures	78
Inschakelen van de controller	80
Starten van de pomp	80
Stoppen van de pomp	80
Onderhoud	80
Afvalverwerking	81
Foutmeldingen	82

Vertaling van de originele instructies



Algemene informatie

Deze apparatuur is bestemd voor beroepsmatig gebruik. De gebruiker wordt verzocht aandachtig deze handleiding en alle overige door Agilent verstrekte informatie door te lezen alvorens het apparaat in gebruik te nemen. Agilent acht zich niet aansprakelijk voor de gevolgen van het niet of gedeeltelijk in acht nemen van de aanwijzingen, onoordeelkundig gebruik door niet hiervoor opgeleid personeel, reparaties waarvoor geen toestemming is verkregen of gebruik in strijd met de specifieke nationale wetgeving. De controllers van de Turbo-V 3K-T zijn frequentieomzetter die gestuurd worden door een microprocessor, zijn gemaakt van halfgeleider-elementen en zijn in staat om zelfdiagnose en zelfbescherming uit te voeren.

Deze handleiding hanteert de volgende symbolen:

VOORZICHTIG! Bij dit symbool staat tekst met procedures die, indien niet opgevolgd, schade aan apparatuur kunnen veroorzaken

WAARSCHUWING! Bij dit symbool staat tekst die de aandacht van de operator vestigt op een speciale procedure of methode die, indien niet correct uitgevoerd, ernstig lichamelijk letsel kan veroorzaken.



OPMERKING De opmerkingen bevatten belangrijke informatie die uit de tekst is gelicht.

Opslag

Tijdens het transport en de opslag van de controllers moeten de volgende omgevingscondities aanwezig zijn:

- temperatuur: van -20 °C tot +70 °C
- relatieve vochtigheid: 0 – 95 % (niet condenserend)

Voorbereiding voor installatie

De controller wordt in een speciale beschermende verpakking geleverd; als er schade wordt geconstateerd die tijdens het transport veroorzaakt zou kunnen zijn, meteen contact opnemen met het plaatselijke verkoopkantoor. Zorg er bij het uitpakken voor dat de controller niet kan vallen of stoten te verduren krijgt.

Laat de verpakking niet ergens buiten achter. Het verpakkingsmateriaal is volledig recyclebaar en voldoet aan de EEG milieuriichtlijn 85/399.

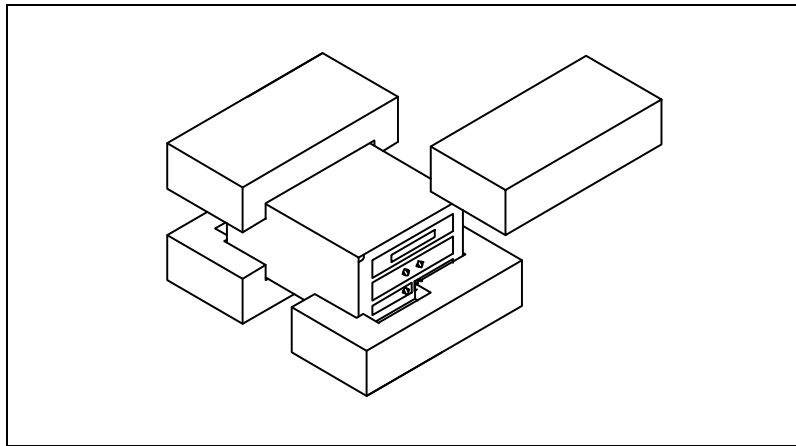

Figuur 1 Verpakking van de Controllers

Agilent heeft elke controller voorbereid voor een bepaalde voedingsspanning:

- het model 869-9447 voor 220 Vac
- het model 869-9547 voor 120 Vac

Controleer of de juiste spanning is gekozen en sluit de voedingskabel weer aan.

Installatie

WAARSCHUWING!



De controller is voorzien van een voedingskabel met drie draden en een stekker van het internationaal goedgekeurde type. Gebruik altijd deze voedingskabel en steek de stekker in een geaard contactstop om elektrische ontladingen te voorkomen. In de controller ontwikkelen zich hoge spanningen die zware beschadigingen of de dood kunnen veroorzaken. Alvorens installatie- of onderhoudswerkzaamheden uit te voeren, de controller van de contactstop afkoppelen.

OPMERKING

De controller kan op een tafel of in een speciaal rack worden geïnstalleerd. In ieder geval moet de koellucht vrij rondom het apparaat kunnen circuleren. De controller mag niet geïnstalleerd en/of gebruikt worden in ruimten die blootgesteld zijn aan de weersomstandigheden (regen, vorst, sneeuw), stof, agressieve gassen, of in ruimten met explosiegevaar of zeer hoog brandgevaar.

Tijdens de werking moeten de volgende omgevings-condities aanwezig zijn:

- temperatuur: van 0 °C tot +40 °C
- relatieve vochtigheid: 0 – 95 % (niet condenserend).

Gebruik voor aansluiting van de controller op de pomp de speciale kabel van de controller.

Voor de overige aansluitingen en de installatie van de accessoires wordt verwezen naar het hoofdstuk "Technical Information".

Gebruik

In deze paragraaf worden de voornaamste bedieningswijzen uitgelegd. Voor meer informatie of procedures die aansluitingen of speciale opties betreffen wordt verwezen naar de paragraaf "Use" van de bijlage "Technical Informations". Breng, alvorens de controller in gebruik te nemen, alle elektrische en pneumatische aansluitingen tot stand en raadpleeg hiervoor de handleiding van de aan te sluiten pomp.

WAARSCHUWING!



Indien de pomp op een tafel is geplaatst, controleren of deze stabiel staat om letsel aan personen en schade aan het apparaat te voorkomen. Laat de pomp nooit werken zonder dat de ingangsfens aan het systeem is gekoppeld of de afsluitfens is gesloten.

OPMERKING

De connector J1 moet met zijn jumper aangesloten blijven als geen externe aansluiting tot stand wordt gebracht. De pre-vacuümpomp en de Turbo-V pomp mogen beide gelijktijdig ingeschakeld zijn.

Bedieningsorganen, Controlelampjes en Connectoren van de Controller

Hier volgt de beschrijving van het bedieningspaneel van de controller en van de doorverbindingspanelen. Voor meer informatie wordt verwezen naar het hoofdstuk "Technical Information".

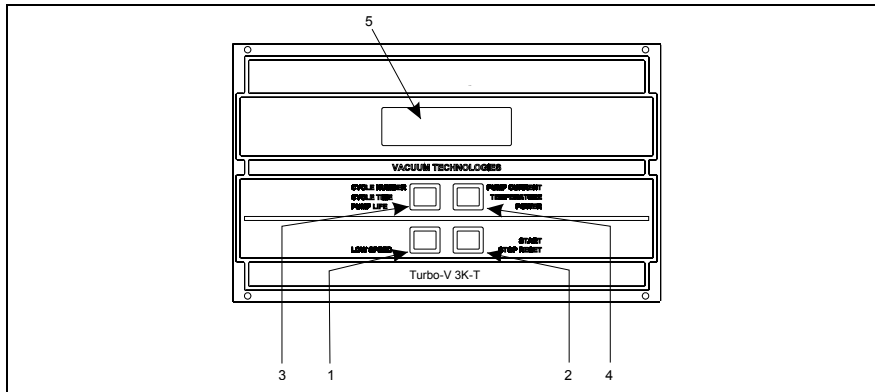

Figuur 2 Frontpaneel van de controllers 869-9447 en 869-9547

- 1 Drukknop voor selectie van de bedrijfswijze HIGH/LOW SPEED. Is alleen actief wanneer de bedrijfswijze op het frontpaneel wordt geselecteerd. Door de knop herhaaldelijk in te drukken, gaat de pomp cyclisch van HIGH SPEED naar LOW SPEED over.
- 2 Drukknop voor het zenden van de sturingen START, STOP of REST. Is alleen actief wanneer de bedrijfswijze op het frontpaneel wordt geselecteerd. Door de knop een maal in te drukken wordt de startfase geactiveerd; door de knop opnieuw te bedienen wordt de pomp gestopt. Als de pomp automatisch is gestopt ten gevolge van een storing, moet deze knop een eerste maal worden bediend om de controller te resetten en een tweede maal om de pomp weer op te starten.
- 3 Drukknop voor weergave op het display van de parameters cycle number, cycle time en pump life en serienummer.
- 4 Drukknop voor weergave op het display van de parameters pump current, pump temperature, pump power, rotational speed, gemeten stromingswaarde, type gas en alarmstatus. Is altijd actief, onafhankelijk van de gekozen bedrijfswijze. Door drukknoppen 3 en 4 gelijktijdig gedurende ten minste 2 seconden in te drukken, wordt een programma gestart waarmee enkele bedrijfsparameters kunnen worden geprogrammeerd.
- 5 Alfnumeriek display met vloeibare kristallen (LCD): puntjespatroon, 2 lijnen x 16

karakters.

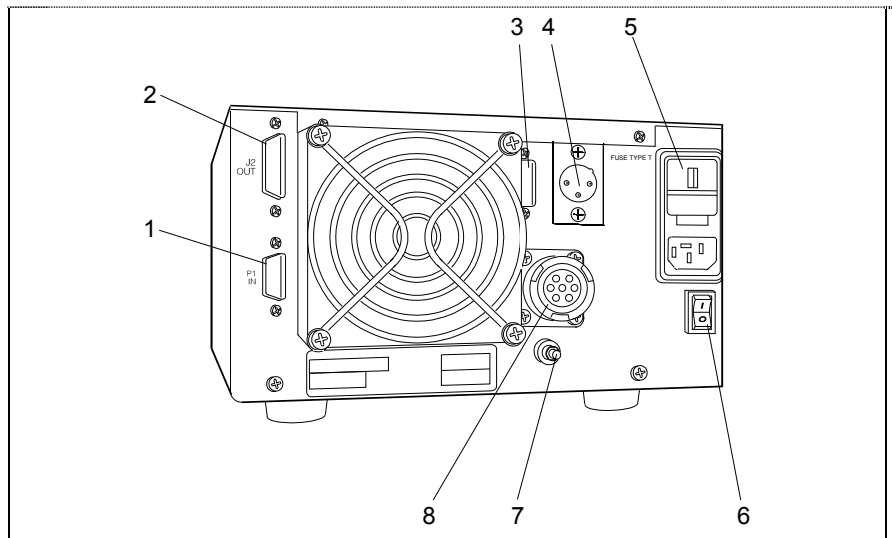

Figuur 3 Achterpaneel van de controllers 869-9447 en 869-9547

1	Connector voor ingang logische signalen (de te koppelen connector wordt met de speciale sluitklem geleverd).
2	Connector voor uitgang logische signalen en controle pompstroom en bekrachtigingsfrequentie.
3	Ruimte bestemd voor de connector van de seriële communicatiepoort RS-232 – RS-485 (geleverd als optie).
4	Ontluchttingsconnector.
5	Ingangsmodule van de voeding voor de controller. Omvat zekering, spanningswisseling, krachtcontact- stop en EMC filter.
6	Hoofdschakelaar.
7	Aardaansluiting.
8	Connector voor pompkabel.

Gebruiksprocedures

Inschakelen van de controller

Om de controller in te schakelen, de voedingskabel in de netcontactdoos inbrengen en de stroomschakelaar in stand 1 zetten.

Starten van de pomp

Voor het starten van de pomp de START knop op het frontpaneel bedienen.

Stoppen van de pomp

Voor het stoppen van de pomp de STOP knop op het frontpaneel bedienen.

Onderhoud

De controllers van de serie Turbo-V 3K-T zijn onderhoudsvrij. Eventuele werkzaamheden moeten door bevoegd personeel worden uitgevoerd.

In geval van storing is het mogelijk om de reparatiedienst van Agilent of de "Agilent advanced exchange service" in te schakelen: zo krijgt men een ruilcontroller ter vervanging van de defecte controller.

WAARSCHUWING!



Alvorens werkzaamheden aan de controller uit te voeren, de voedingskabel afkoppelen.

Mocht de controller gesloopt worden, ga dan overeenkomstig de specifieke nationale wetgeving te werk.

Afvalverwerking

Betekenis van het logo "WEEE" op de etiketten. Het onderstaande symbool wordt aangebracht in overeenstemming met de EG-richtlijn "WEEE". Dit symbool (**alleen geldig voor de landen van de Europese Gemeenschap**) geeft aan dat het product waarop het is aangebracht, NIET mag worden afgevoerd samen met normaal huisvuil of industrieel afval, maar gescheiden moet worden ingezameld. De eindgebruiker wordt dus verzocht contact op te nemen met de leverancier van het apparaat, zij het de fabrikant of een wederverkoper, om het proces van gescheiden inzameling en verwerking in gang te zetten, na de van toepassing zijnde termen en voorwaarden van het verkoopcontract te hebben gecontroleerd.

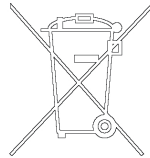

Foutmeldingen

In geval van storingen wekt het zelfdiagnose-circuit van de controller enkele foutmeldingen op die in de volgende tabel zijn omschreven.

Tab. 1

FOUTMELDING	OMSCHRIJVING	REMEDIE
CHECK CONNECTION TO PUMP	Foutieve verbinding tussen pomp en controller.	Controleer of de verbindingskabel tussen pomp en controller aan beide uiteinden goed bevestigd is en geen onderbrekingen vertoond. Bedien twee maal de START-knop om de pomp weer op te starten.
PUMP WAITING INTERLOCK	Het interlock-signaal op connector P1 is actief wegens onderbreking van de kortsluiting tussen pin 3 en pin 8 van connector J1 of wegens het openen van het externe interlock-signaal.	Herstel de kortsluiting tussen pin 3 en pin 8 van connector J1 of sluit het externe interlock-signaal.
FAULT: PUMP OVERTEMP.	De temperatuur van het bovenste pomplager bedraagt meer dan 60 °C. De temperatuur van het onderste pomplager bedraagt meer dan 100 °C.	Wacht tot de temperatuur weer onder de drempelwaarde is gezakt. Bedien twee maal de START-knop om de pomp weer op te starten.
FAULT: CONTROLLER OVERTEMPERATURE	De temperatuur van de transformator van de controller bedraagt meer dan 90 °C.	Wacht tot de temperatuur weer onder de drempelwaarde is gezakt. Bedien twee maal de START-knop om de pomp weer op te starten.
FAULT: TOO HIGH LOAD	Tijdens normale werking ligt de door de pomp geabsorbeerde stroom hoger dan de geprogrammeerde waarde (8 A).	Controleer of de pomprotor vrij kan draaien. Bedien twee maal de START-knop om de pomp weer op te starten.

FOUTMELDING	OMSCHRIJVING	REMEDIE
FAULT: SHORT CIRCUIT	Tijdens normale werking (na startfase) is de uitgangsverbinding in kortsluiting (uitgangsstroom groter dan 16 A).	Controleer de verbindingen tussen pomp en controller. Bedien twee maal de START-knop om de pomp weer op te starten.
OVERVOLTAGE	Er is een storing opgetreden in het voedingsgedeelte van de controller, of de controller heeft een stoorsignaal ontvangen.	Bedien twee maal de START-knop om de pomp weer op te starten. Als de melding weer verschijnt, zich voor onderhoud tot Agilent wenden.
FLOW METER ALARM	Alarm betreffende de reinigingsstroom. De stromingswaarde is gedurende 10 of meer seconden beneden de ingestelde drempelwaarde gebleven.	Controleer of het gastoevoercircuit correct functioneert.

6 **Bedrijfshandleiding** **Foutmeldingen**

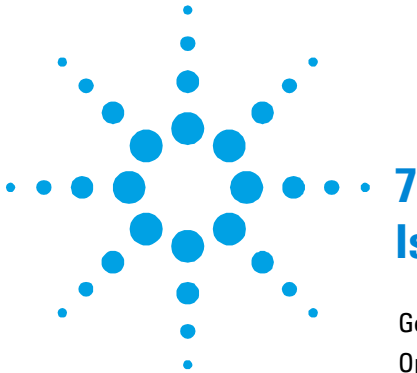

7 Instruktionsbog

Generel Information	86
Opbevaring	86
Forberedelser før installation	87
Installation	88
Anvendelse	89
Kontroller, Indikatorer og Kontakter på Styreenheden	90
Instruktion	92
Start af styreenheden	92
Start af pumpen	92
Stop af pumpen	92
Vedligeholdelse	92
Bortskaffelse	93
Fejlmeddelelser	94

Oversættelse af originalinstruktionerne



Generel Information

Dette materiel er beregnet til professionel anvendelse. Brugeren bør læse denne brugsanvisning og anden yderligere information fra Agilent, før udstyret anvendes. Agilent tager ikke ansvar for skader helt eller delvis som følge af tilsidesættelse af disse instruktioner, fejlagtig brug af personer uden tilstrækkelig kendskab, ukorrekt anvendelse af udstyret eller håndtering, der strider imod gældende lokale regler.

Styreenhederne i Turbo-V 3K-T serien er mikro-processorstyrede frekvens-omformere, der består af komponenter med fast tilstand.

I brugsanvisningen anvendes følgende standard-rubrikker:

FORSIGTIG!

Denne advarselsmeddelelse vises før procedurer, der skal følges nøje for ikke at risikere maskinskader.

ADVARSEL!



Advarselsmeddelelserne informerer operatøren om, at en speciel procedure eller en vis type arbejde skal udføres præcist efter anvisningerne. I modsat fald er der risiko for svære personskader.

BEMÆRK

Dette gør opmærksom på vigtig information i teksten.

Opbevaring

Følgende krav til omgivelsesforholdene gælder ved transport og opbevaring af styreenheden:

- temperatur: fra -20 °C til +70 °C
- relativ luftfugtighed: 0 – 95 % (ikke kondenserende)

Forberedelser før installation

Styreenheden leveres i en speciel beskyttende emballage. Kontakt den lokale forhandler, hvis emballagen viser tegn på skader, der kan være opstået under transporten. Sørg for at styreenheden ikke tabes eller udsættes for stød ved udpakningen.

Smid ikke emballagen ud. Materialet kan genbruges 100 % og opfylder EU-direktiv 85/399 om miljøbeskyttelse.

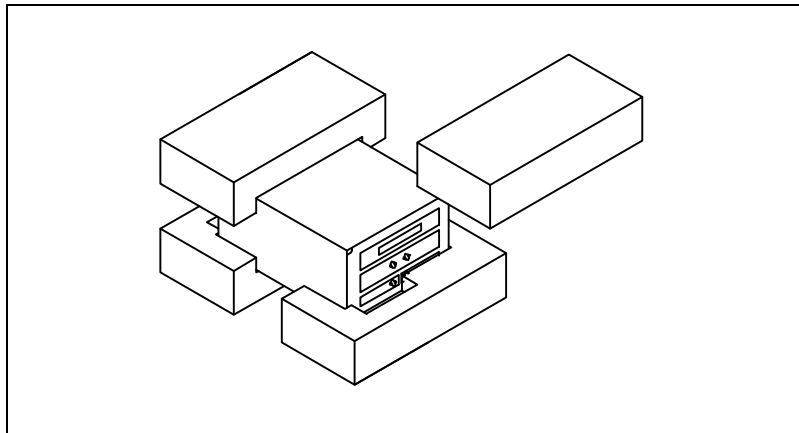

Figur 1 Styreenhedens emballage

Styreenheden leveres fra Agilent forindstillet til en vis strømforsyning:

- modellen 869-9447 til 220 V vekselstrøm
- modellen 869-9547 til 120 V vekselstrøm

Kontrollér at den valgte spænding er korrekt. Tilslut strømkablet.

Installation

ADVARSEL!



Styreenheden leveres med strømkabel med tre ledere og godkendt stik efter internationale standarder. Anvend udelukkende det medleverede strømkabel. Stikket må kun tilsluttes et vægudtag med fungerende jordtilslutning, for at undgå elektriske stød. Spænding frembragt i styreenheden kan nå høje værdier og forårsage stor skade og dødsfald. Frakobl altid strømkablet, inden der udføres installations- eller vedligeholdelsesarbejde på styreenheden.

BEMÆRK

Styreenheden kan installeres på et bord eller et velegnet stativ. I begge tilfælde skal der være plads nok til, at luft kan cirkulere frit omkring apparatet. Installér og anvend ikke styreenheden i miljøer, der udsættes for påvirkninger fra atmosfæren (regn, sne, is), damp, aggressive gasser, og ligeledes ikke i eksplosivt eller brandfarligt miljø.

Følgende krav til omgivelserforholdene gælder ved drift:

- temperatur: fra 0 °C til +40 °C
- relativ luftfugtighed: 0 – 95 % (ikke kondenserende)

Pumpen og styreenheden tilsluttes med det specielle kabel, der leveres med styreenheden.

For øvrige tilslutninger og installation af tilbehør henvises til afsnittet "Technical Information".

Anvendelse

Dette afsnit beskriver de vigtigste driftsprocedurer. For en detaljeret beskrivelse samt procedurer, der involverer tilslutninger eller tilbehør, henvises til afsnittet "Use" i bilag "Technical Information". Inden styreenheden anvendes, bør samtlige elektriske og pneumatiske tilslutninger udføres. Læs brugsanvisningen før pumpen tilsluttes.

ADVARSEL!



Sørg for, at pumpen står fast, hvis den er installeret på et bord. Dette er for at forebygge skader på apparatet og personer. Start aldrig pumpen, hvis pumpeilløbet ikke er tilsluttet systemet eller er blokeret.

BEMÆRK

Afbryderkontakten J1 skal forblive tilsluttet med aktuel bro, når der ikke udføres eksterne tilslutninger. Forvakuumpumpen og Turbo-V-pumpen skal fungere samtidigt.

Kontroller, Indikatorer og Kontakter på Styreenheden

Følgende beskriver manøvrepanelet til styreenheden samt tilslutningspanelerne. For yderligere information henvises til bilag "Technical Information".

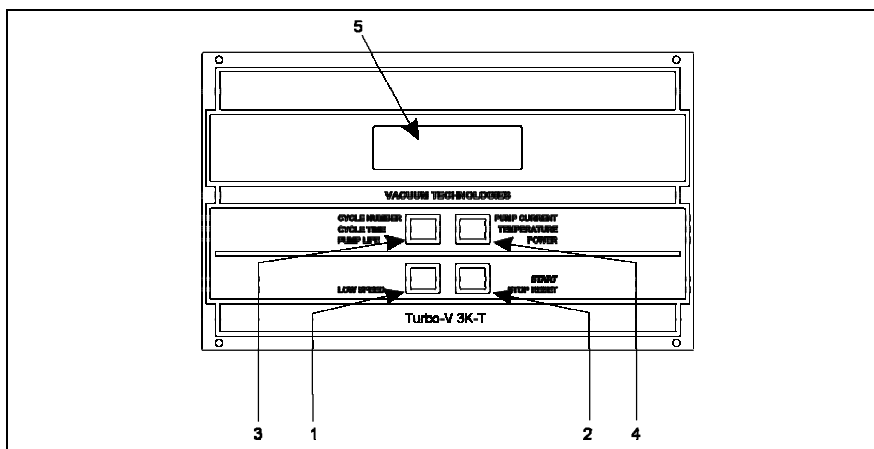

Figur 2 Frontpanelet på Styreenheden 869-9447 og 869-9547

- | | |
|---|--|
| 1 | Trykknop til valg af HIGH/LOW SPEED driftvalg. Trykknappen fungerer kun, når der vælges drift fra frontpanelet. Ved at trykke på knappen flere gange efter hinanden skiftes fra HIGH SPEED til LOW SPEED. |
| 2 | Trykknop til overføring af START, STOP eller RESET. Trykknappen fungerer kun, når der vælges fra frontpanelet. Tryk på knappen en gang for at starte pumpen, tryk på knappen igen for at standse pumpen. Hvis pumpen standser automatisk ved en fejl, tryk på denne knap en gang for at tilbagesætte styreenheden, og yderligere en gang for at starte pumpen igen. |
| 3 | Trykknop til at hente cycle number, cycle time og pump lift frem på displayet og serienummer. |
| 4 | Trykknop til fremvisning af pump current, pump temperature, pump power, rotational speed, værdi for gennemstrømning, gastype samt alarmtilstand på displayet. Trykknappen fungerer uafhængigt af den valgte styretype. Når trykknapperne 3 og 4 holdes trykket ind samtidigt i mindst 2 sekunder, starter et program, der gør det muligt, at programmere visse driftparametre. |
| 5 | LCD-display med tal og bogstaver: punktmatrice, 2 rader med 16 tegn. |

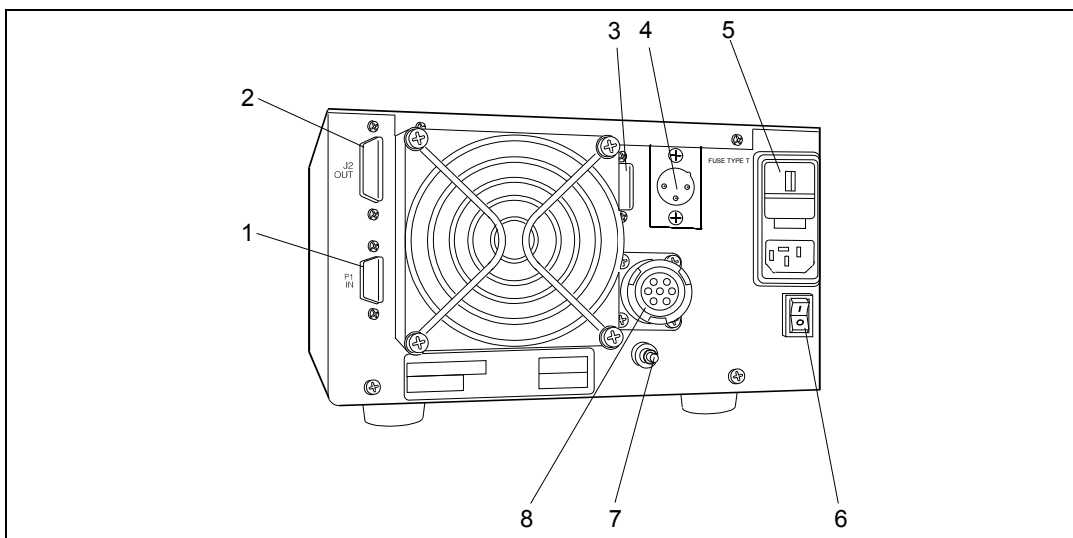

Figur 3 Bageste panel på styreenheden 869-9447 og 869-9547

1	Indgangskontakt til logiske signaler (tilslutningskontakten leveres med specielt forbindelsesbro).
2	Udgangskontakten til logiske signaler og kontrol af pumpens strøm samt tilkoblingsfrekvens.
3	Tilgængelig plads til kontakt til serieport RS-232 – RS-485 (leveres som tilbehør).
4	Udløbskonnektor.
5	Spændingsindgangsmodul til styreenheden. Modulet omfatter hovedsikringer, spændingsomkobler, udtag til hovedledning og EMC-filter.
6	Linieafbryder. Kontakt til forsyningskabel til heater jacket.
7	Jordforbindelse.
8	Kontakt til pumpens kabel.

Instruktion

Start af styreenheden

Styreenheden startes ved at sætte strømkablet i vægudtaget og sæt hovedafbryderen i stilling 1.

Start af pumpen

Pumpen startes ved at trykke på START-trykknappen.

Stop af pumpen

Pumpen stopper ved at trykke på STOP-trykknappen på frontpanelet.

Vedligeholdelse

Styreenhederne i Turbo-V 3K-T behøver ikke nogen vedligeholdelse. Ethvert indgreb på pumpen skal foretages af autoriseret personale.

Hvis pumpen går i stykker, kan man benytte sig af Agilents reparations-service eller Agilent udvekslingsservice, hvor man kan få en repareret pumpe i bytte for den, der er gået i stykker.

ADVARSEL!

Inden der foretages noget som helst indgreb på styreenheden, skal strømmen først afbrydes.



Skrotning af pumpen skal foregå i overensstemmelse med det pågældende lands særlige love.

Bortskaffelse

Betydningen af "WEEE" logoet på mærkaterne. Nedenstående symbol anvendes i overensstemmelse med det såkaldte EU-direktiv "WEEE". Symbolet (**kun gældende for EU-landene**) viser, at produktet, som det sidder på IKKE må bortskaffes sammen med affald fra private husholdninger eller industriel affald men skal indleveres på en godkendt affaldsstation. Vi opfordrer derfor slutbrugeren til at kontakte leverandøren af anordningen, enten fabrikken eller en forhandler, for igangsættelse af afhentnings- og bortskaffelsesprocessen efter nøje at have kontrolleret betingelserne i salgskontrakten.

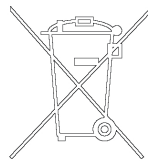

Fejlmeddelelser

Når visse fejl opstår, viser styreenheden ved selvdiagnose aktuelle fejl på displayet. De mulige meddelelser beskrives i tabellen på følgende side.

Tab. 1

MEDDELELSE	BESKRIVELSE	KONTROL
CHECK CONNECTION TO PUMP	Tilslutning mellem pumpe og styreenhed er defekt.	Kontrollér at tilslutningskabel mellem pumpe og styreenhed er korrekt monteret samt at ingen afbrydninger forekommer. Tryk to gange på START for at starte pumpen igen.
PUMP WAITING INTERLOCK	Interlocksignalet findes på kontakt P1 p.g.a. kortslutning mellem stift 3 og stift 8 i kontakten J1 eller p.g.a. at det eksterne interlocksignal er åbent.	Tilbagestil kortslutningen mellem stift 3 og stift 8 på kontakt J1 eller sluk for det eksterne interlocksignal.
FAULT: PUMP OVERTEMP.	Temperaturen i det øverste leje eller pumpen er over 60 °C.	Vent på, at temperaturen falder til under tærskelværdi. Tryk to gange på START for at starte pumpen igen.
FAULT: CONTROLLER OVERTEMPERATURE	Temperaturen på styreenhedens transformator er over 90 °C.	Vent på, at temperaturen falder til under tærskelværdi. Tryk to gange på START for at starte pumpen igen.
FAULT: TOO HIGH LOAD	Under normal drift er pumpens strømforbrug større end den programmerede værdi.	Kontrollér, at pumpens rotor kan rotere frit. Tryk to gange på START for at starte pumpen igen.
FAULT: SHORT CIRCUIT	Under normal drift (efter startfasen) er udgangseffekten kortsluttet.	Kontrollér forbindelserne mellem pumpe og styreenhed. Tryk to gange på START for at starte pumpen igen.

MEDDELELSE	BESKRIVELSE	KONTROL
OVERVOLTAGE	Defekt i styreenhedens forsyning, eller styreenheden har modtaget et ikke korrekt signal.	Tryk to gange på START for at starte pumpen igen. Såfremt meddelelsen fremvises på ny, rettes henvendelse til Agilent for foretagelse af vedligeholdelse.
FLOW METER ALARM	Alarm for udluftningsventil. Værdien for gennemstrømningen er under den indtastede tærskelværdi i et tidsrum på min. 10 sekunder.	Kontrollér, at kredsløbet til gasforsyning fungerer korrekt.

7 **Istruktionsbog** **Fejlmeddelelser**

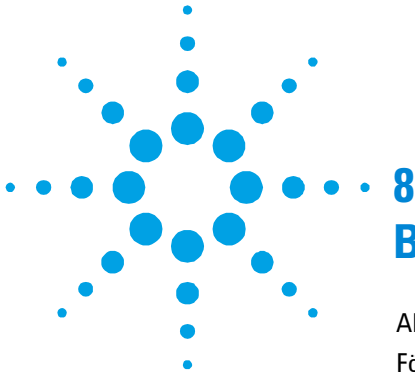

8

Bruksanvisning

Allmän Information	98
Förvaring	98
Förberedelser för installation	99
Installation	100
Användning	101
Kontroller, Indikatorer och Kontakter på Styrenheten	102
Instruktioner för bruk	104
Start av styrenheten	104
Start av pumpen	104
Stopp av pumpen	104
Underhåll	104
Bortskaffning	105
Felmeddelanden	106

Översättning av originalinstruktionerna



Allmän Information

Utrustningen är avsedd för yrkesmässig användning. Användaren bör läsa denna bruksanvisning, samt övrig dokumentation från Agilent före användning av utrustningen. Agilent tar inget ansvar för skador som helt eller delvis orsakats av åsidosättande av instruktionerna, olämplig användning av person utan tillräcklig kunskap, obehörigt bruk av utrustningen eller hantering som strider mot gällande lokala föreskrifter.

Styrenheterna i Turbo-V 3K-T är mikroprocessorstyrda frekvensomvandlare som består av komponenter med fast tillstånd. Styrenheterna är försedda med självdiagnos- och självskyddsfunktion.

I bruksanvisningen används följande standard-rubriker:

OBSERVER!

Detta varningsmeddelande visas framför procedurer som måste följas exakt för att undvika skador på maskinen.

VARNING!



Varningsmeddelandena informerar operatören om att en speciell procedur eller en viss typ av arbete måste utföras exakt enligt anvisningarna. I annat fall finns risk för svåra personskador.

OBSERVERA

Detta visar på viktig information i texten.

Förvaring

Följande krav på omgivningsförhållanden gäller vid transport och förvaring av styrenheten:

- temperatur: från -20 °C till +70 °C
- relativ luftfuktighet: 0 – 95 % (utan kondens)

Förberedelser för installation

Styrenheten levereras i ett särskilt skyddande emballage. Kontakta det lokala försäljningskontoret om emballaget visar tecken på skador som kan ha uppstått under transporten. Se till att styrenheten inte tappas eller utsätts för stötar vid upppackningen.

Kasta inte packmaterialet i soporna. Materialet är återvinningsbart till 100 % och uppfyller EU-direktiv 85/399 om miljöskydd.

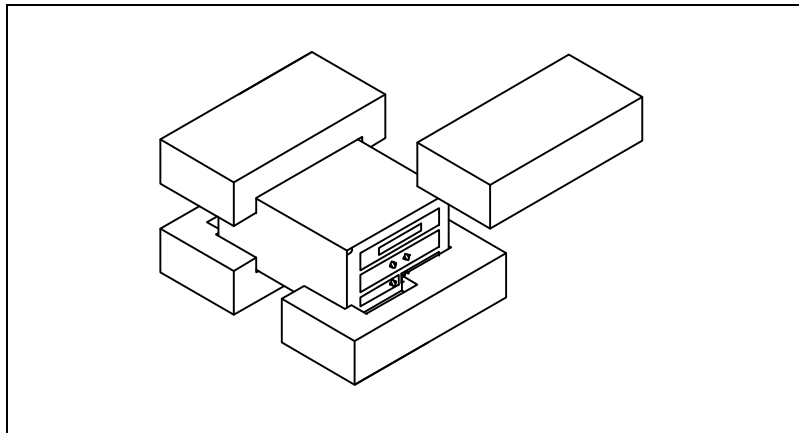

Figur 1 Styrenhetens förpackning

Styrenheten levereras från Agilent med förinställning för en viss matningsspänning:

- modellen 869-9447 för 220 V växelström
- modellen 869-9547 för 120 V växelström

Kontrollera att den valda matningsspänningen är korrekt. Återanslut strömkabeln.

Installation

VARNING!



Styrenheten levereras med strömkabel med tre ledare och godkänd stickpropp enligt internationella standarder. Använd endast den medlevererade strömkabeln. Stickproppen får endast anslutas till ett vägguttag med fungerande jordanslutning för att undvika elstötar. Spänningen inuti styrenheten kan nå höga värden och förorsaka allvarliga skador och dödsfall. Frånkoppla alltid strömkabeln innan något installations- eller underhållsmoment utförs på styrenheten.

OBSERVERA

Styrenheten kan installeras på ett bord eller inuti ett därtill avsett rack. I samtliga fall måste dock kylluften kunna cirkulera fritt kring apparaten. Installera och använd inte styrenheten i miljöer som utsätts för påverkan från atmosfären (regn, snö, is), damm, aggressiva gaser, och inte heller i explosiv eller brandfarlig miljö.

Följande krav på omgivningsförhållanden gäller vid drift:

- temperatur: från 0 °C till +40 °C
- relativ luftfuktighet: 0 – 95 % (utan kondens)

Pumpen och styrenheten ansluts med den speciella kabeln, som levereras med styrenheten.

Beträffande övriga anslutningar och installation av tillbehör hänvisas till avsnittet "Technical Information".

Användning

Detta avsnitt beskriver de viktigaste driftmomenten. För en detaljerad beskrivning samt beträffande moment som involverar anslutningar eller tillbehör hänvisas till avsnittet "Use" i bilaga "Technical Information". Innan styrenheten används bör samtliga elektriska och pneumatiska anslutningar utföras. Läs bruksanvisningen för den anslutna pumpen.

VARNING!



Försäkra dig om att pumpen står stadigt, om den är installerad på ett bord, detta för att förebygga skador på apparaten och personer. Sätt aldrig igång pumpen, om intagsflänsen varken är kopplad till systemet eller är blockerad på plats med låsflänsen.

OBSERVERA

Stängningskontakten J1 måste lämnas ansluten med aktuell brygga om ingen extern anslutning utförs. Förvakumpumpen och Turbo-V-pumpen kan fungera samtidigt.

Kontroller, Indikatorer och Kontakter på Styrenheten

Nedan beskrivs manöverpanelen för styrenheten samt anslutningspanelerna. För ytterligare information hänvisas till bilaga "Technical Information".

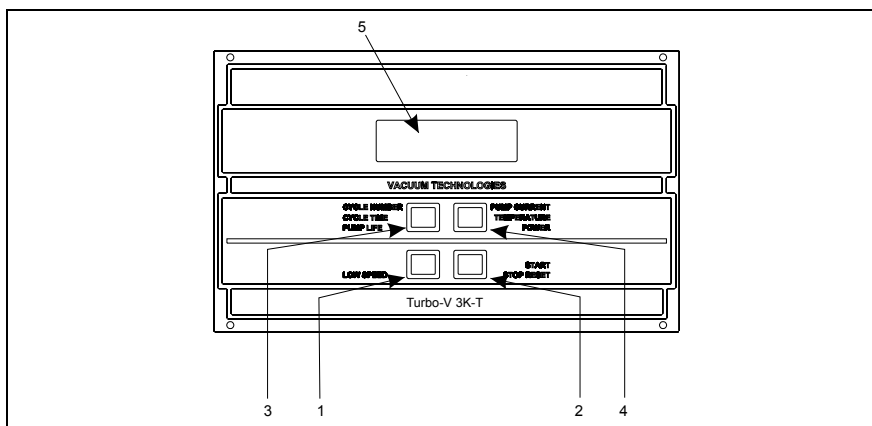

Figur 2 Frontpanelen på Styrenheten 869-9447 och 869-9547

1	Tryckknapp för inställning av HIGH/LOW SPEED driftsätt. Tryckknappen fungerar endast när styrsätt från frontpanelen har valts. Genom att trycka på knappen upprepade gånger går du stegvis från HIGH SPEED till LOW SPEED driftsättet.
2	Tryckknapp för överföring av START, STOP eller RESET. Tryckknappen fungerar endast när styrsätt från frontpanelen har valts. Tryck på knappen en gång för att starta pumpen, tryck på knappen igen för att stanna pumpen. Om pumpen stannat automatiskt i samband med ett fel, tryck på denna knapp en gång för att återställa styrenheten, och ytterligare en gång för att starta om pumpen.
3	Tryckknapp för att hämta parametrarna cycle number, cycle time och pump life på displayen och serienummer.
4	Tryckknapp för att hämta parametrarna pump current, pump temperature, pump power, rotational speed, det uppmätta flödesvärdet, gastyp och larmtillstånd på displayen. Tryckknappen fungerar alltid, oavsett det valda styrsättet. När tryckknapparna 3 och 4 hålls samtidigt intryckta i minst 2 sekunder, startas ett program som tillåter att programmera vissa driftparametrar.
5	LCD-display med siffror och bokstäver: punktmatris, 2 rader med 16 tecken.

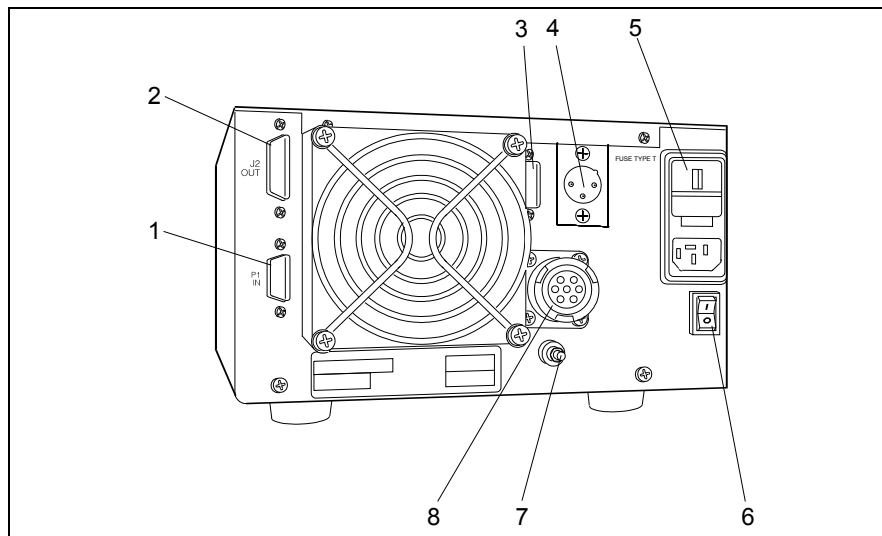

Figur 3 Bakre panel på Styrenheten 869-9447 och 869-9547

1	Ingångskontakt för logiska signaler (anslutningskontakten levereras med speciell stängningsbrygga).
2	Utgångskontakt för logiska signaler och kontroll av pumpens ström samt magnetiseringsfrekvens.
3	Tillgängligt utrymme för kontakt till seriell port RS-232 –RS-485 (levereras som tillbehör).
4	Dräneringskoppling.
5	Spänningsingångsmodul för styrenheten. Modulen omfattar skyddssäkring, spänningsomkopplare, uttag för spänningsmatning och EMC-filter.
6	Nätbrytare.
7	Jordanslutning.
8	Pumpens kontaktkabel.

Instruktioner för bruk

Start av styrenheten

Styrenheten startas enkelt genom att sätta strömkabeln i vägguttaget och sätt huvudströmbrytaren i läge 1.

Start av pumpen

Pumpen startas genom att trycka på tryckknappen START.

Stopp av pumpen

Pumpen stoppas genom att trycka på tryckknappen STOPP på frontpanelen.

Underhåll

Styrenheterna i Turbo-V 3K-T är underhållsfria. Allt servicearbete måste utföras av auktoriserad personal.

Om styrenheten havererar, kontakta Agilent reparationsverkstad eller Agilent utbytesservice, som kan ersätta styrenheten med en renoverad styrenhet.

VARNING!



Innan något arbete utförs på styrenheten måste dess strömförsörjning brytas.

Skrotning av pumpen ska ske enligt gällande lagstiftning.

Bortskaffning

Betydelse av logotypen "WEEE" på etiketterna. Symbolen som visas nedan har tillämpats i enlighet med CD-direktivet som har betecknats som "WEEE". Den här symbolen (**gäller endast i de länder som tillhör den Europeiska Unionen**) indikerar att produkten på vilken symbolen har applicerats INTE får skaffas bort tillsammans med vanliga hushålls- eller industriavfall, men att däremot ett differentierat uppsamlingsystem måste upprättas. Vi rekommenderar därför att slutanvändaren tar kontakt med leverantören av anordningen, oberoende om det handlar om moderföretaget eller återförsäljaren, för att kunna starta uppsamlings- och bortskaffningsprocessen, detta efter lämplig kontroll av kontraktsevenliga tidsgränser och försäljningsvillkor.

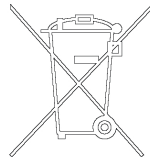

Felmeddelanden

När vissa fel uppstår visar styrenhetens självdiagnoskrets aktuellt felmeddelande på displayen. De möjliga meddelandena listas i följande tabell.

Tab. 1

MEDELANDE	BESKRIVNING	ÅTGÄRD
CHECK CONNECTION TO PUMP	Anslutningen mellan pump och styrenhet är defekt.	Kontrollera att anslutningskabeln mellan pump och styrenhet är ordentligt monterad samt att inget avbrott förekommer. Tryck två gånger på knappen START för att starta om pumpen.
PUMP WAITING INTERLOCK	Interlock-signalen finns på kontakt P1 på grund av kortslutning mellan stift 3 och stift 8 i kontakten J1, eller på grund av att den externa interlock-signalen är öppen.	Åtgärda kortslutningen mellan stift 3 och stift 8 på kontakt J1 eller stäng den externa interlock-signalen.
FAULT: PUMP OVERTEMP.	Temperaturen på det övre lagret eller pumpen överskrider 60 °C.	Vänta tills temperaturen sjunker under tröskelvärdet. Tryck två gånger på knappen START för att starta om pumpen.
FAULT: CONTROLLER OVERTEMPERATURE	Temperaturen på styrenhetens transformator överskrider 90 °C.	Vänta tills temperaturen sjunker under tröskelvärdet. Tryck två gånger på knappen START för att starta om pumpen.
FAULT: TOO HIGH LOAD	Under normal drift förbrukar pumpen en större effekt än det programmerade värdet.	Kontrollera att pumpens rotor kan rotera fritt. Tryck två gånger på knappen START för att starta om pumpen.

MEDDELANDE	BESKRIVNING	ÅTGÄRD
FAULT: SHORT CIRCUIT	Under normal drift (efter startmomentet) har utgången kortslutits.	Kontrollera anslutningarna mellan pump och styrenhet. Tryck två gånger på knappen START för att starta om pumpen.
OVERVOLTAGE	Ett fel har upptäckts i styrenhetens spänningsmatning eller styrenheten har fått en falsk signal.	Tryck två gånger på knappen START för att starta om pumpen. Om meddelandet upprepas kontakta Agilent för underhåll.
FLOW METER ALARM	Larm angående rengöringsflödet. Värdet är under det inmatade tröskelvärdet under 10 sekunder eller längre.	Kontrollera korrekt funktion av gasens matningskrets.

8 Bruksanvisning

Felmeddelanden

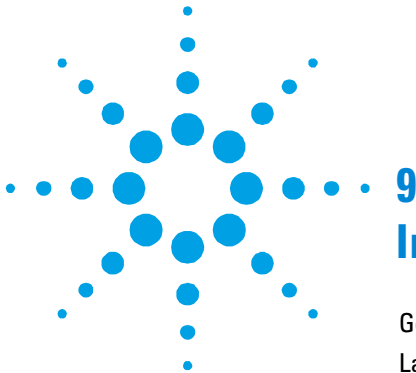

9

Instruksjon Manual

Generell informasjon	110
Lagring	110
Forberede installasjonen	111
Installasjon	112
Bruk	112
Kontroller, Indikatorer og Kontakter på Styreenheten	114
Instruksjoner for bruk	116
Starte styreenheten	116
Starte pumpen	116
Stoppe pumpen	116
Vedlikehold	116
Eliminering	117
Feilmeldinger	118

Oversetting av den opprinnelige samsvarserklæringen



Generell informasjon

Dette utstyret er beregnet til bruk av profesjonelle brukere. Brukeren bør lese denne brukerveiledningen og all annen informasjon fra Agilent før utstyret tas i bruk. Agilent kan ikke holdes ansvarlig for hendelser som skjer på grunn av manglende oppfølging, selv delvis, av disse instruksjonene, feilaktig bruk av utrenet personell, ikke godkjente endringer av utstyret eller handlinger som på noen måte er i strid med nasjonale bestemmelser. Styreenhetene i Turbo-V 3K-T er mikroprosessorstyrte frekvensomformere, som består av komponenter med fast tilstand. Styreenhetene har funksjoner for selvdiagnose og selvbeskyttelse.

Denne veiledningen bruker følgende standard-protokoll:

FORSIKTIG!

Denne advarselen vises foran fremgangsmåter som, dersom de ikke følges, kan føre til at utstyret skades.

ADVARSEL!



Disse meldingene skal tiltrekke seg brukerens oppmerksomhet til en spesiell fremgangsmåte eller praksis som, hvis den ikke følges, kan medføre alvorlige skader.

MERK

Merknadene inneholder viktig informasjon som er hentet fra teksten.

Lagring

Når styreenhetene transporteres eller lagres, må følgende forhold være oppfylt:

- temperatur: fra 20 °C til +70 °C
- relativ fuktighet: 0 – 95 % (uten kondens)

Forberede installasjonen

Styreenheten leveres i en spesiell beskyttelsesemballasje. Viser denne tegn på skader som kan ha oppstått under transporten, må du ta kontakt med det lokale salgskontoret.

Når styreenheten pakkes ut, må du passe på at den ikke slippes ned eller utsettes for noen form for støt.

Emballasjen må ikke kastes på en ulovlig måte. Alle materialer er 100 % resirkulerbare og er i samsvar med EU-direktiv 85/399 om miljøbeskyttelse.

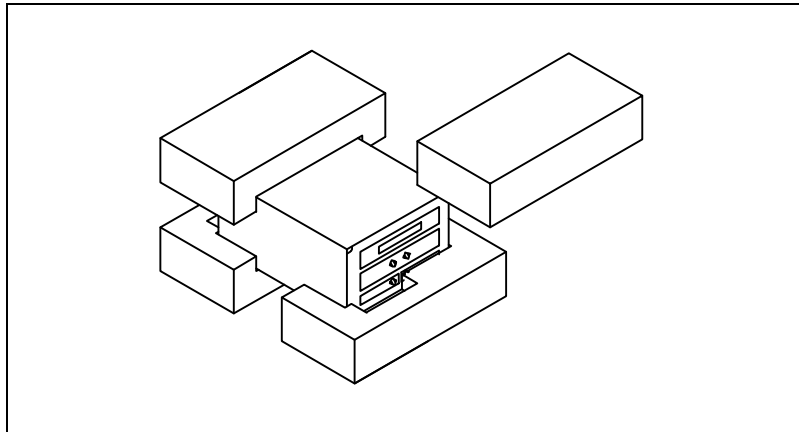

Figur 1 Styreenhetens emballasje

Styreenheten leveres fra Agilent med forhåndsinnstillinger for en viss nettspenning:

- modellen 869-9447 for 220 V vekselstrøm
- modellen 869-9547 for 120 V vekselstrøm

Kontroller at den valgte nettspenningen er korrekt, og kople maskinen til strømnettet.

Installasjon

ADVARSEL!



Styreenheten leveres med strømkabel med tre ledere og godkjent støpsel i henhold til internasjonale standarder. Bruk kun den vedlagte strømkabelen. Støpslet må kun benyttes i en veggkontakt som har tilfredsstillende jording, slik at faren for strømstøt kan unngås. Spenningen inne i styreenheten kan nå høye verdier og kan føre til alvorlige skader og dødsfall. Kople alltid strømkabelen fra strømmettet før alle installasjons- eller vedlikeholdsarbeider som utføres på styreenheten.

MERK

Styreenheten kan installeres på et bord eller inne i et passende stativ. Uansett så må kjøleluften kunne sirkulere fritt rundt apparatet. Ikke installer eller bruk styreenheten i miljøer som utsettes for regn, snø eller is, støv, aggressive gasser, eksplosjonsfarlige miljøer eller i miljøer med stor brannfare.

Under bruk må følgende forhold respekteres:

- temperatur: fra 0 °C til +40 °C
- relativ fuktighet: 0 – 95 % (uten kondens)

Pumpen og styreenheten tilkoples den spesielle kablen som leveres sammen med styreenheten.

Når det gjelder andre tilkoplinger og installasjon av ekstrautstyr vises det til avsnittet "Technical Information".

Bruk

Dette avsnittet beskriver de viktigste driftsmomentene. For en detaljert beskrivelse samt moment som omfatter tilkoplinger eller ekstrautstyr vises det til avsnittet "Use" i vedlegget "Technical Information". Før styreenheten tas i bruk bør samtlige elektriske og pneumatiske tilkoplinger gjøres. Les brukerveiledningen for pumpen som er tilkopleet.

ADVARSEL!



Dersom pumpen er installert på et bord må du kontrollere at pumpen står støtt. Dette er viktig for å forhindre skader på apparatet og på personer. Dersom inngangsslensen hverken er tilkoplest systemet eller dersom den er blokkert av låseflensen må pumpen aldri startes opp.

MERK

Lukkekontakten J1 må være tilkoplest aktuell brygge dersom det ikke skjer en annen ekstern tilkopling. Forvakuumpumpen og Turbo-V-pumpen må fungere sammen.

Kontroller, Indikatorer og Kontakter på Styreenheten

Nedenfor beskrives styrepanelet til styreenheten samt tilkoplingspanelene. For ytterligere informasjon vises det til avsnittet "Accessories and Spare Parts" i vedlegget "Technical Information".

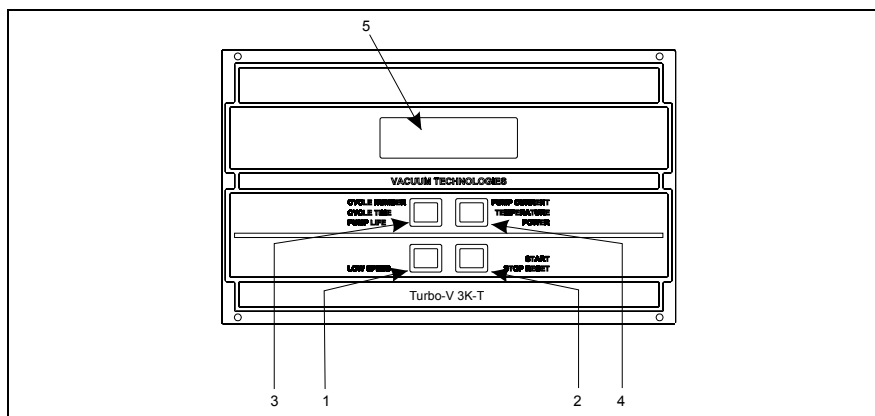

Figur 2 Frontpanelet på styreenheten 869-9447 og 869-9547

1	Trykknapp for innstilling av HIGH/LOW SPEED drift. Trykknappen fungerer kun når det er valgt styremåte fra frontpanelet. Når du trykker på knappen gjentatte ganger, går du omvekslende fra HIGH SPEED til LOW SPEED.
2	Trykknapp for overføring av START, STOP eller RESET. Trykknappen fungerer kun når det er valgt styremåte fra frontpanelet. Trykk på knappen en gang for å starte pumpen, trykk på knappen igjen for å stanse pumpen. Har pumpen stanset automatisk i forbindelse med en feil, trykk en gang på denne knappen for å tilbakestille styreenheten, en gang til for å startet pumpen.
3	Trykknapp for å vise parametrene cycle number, cycle time og pump life på displayet og serienummer.
4	Trykknapp for å vise parametrene pump current, pump temperature, pump power og rotational speed, verdien til målt strømning, gasstypen og alarmtilstanden på displayet. Trykknappen fungerer alltid, uavhengig av styremåten. Når trykknappene 3 og 4 trykkes ned samtidig i minst to sekunder, startes et program som tillater utvelging av visse driftsparametre.
5	LCD-display med siffer og bokstaver: punktmatrix, 2 rader med 16 tegn.

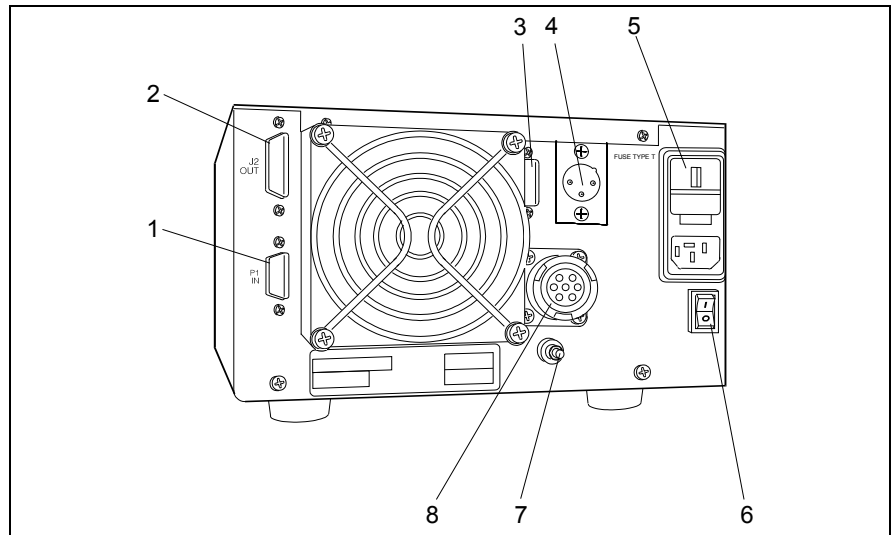

Figur 3 Bakpanelet på styreenheten 869-9447 og 869-9547

1	Inngangskontakt for logiske signaler (tilkoplings-kontakten leveres med spesiell lukkebrygge).
2	Utgangskontakt for logiske signaler og kontroll av pumpens strøm og magnetiseringsfrekvens.
3	Tilgjengelig plass for kontakt til seriekanal RS-232 – RS-485 (leveres som ekstrautstyr).
4	Koplingsstykke for drenering.
5	Spenningsinngangsmodul for styreenheten. Modulen omfatter vernesikring, spenningsomkopler, uttak for spenningsmåling og EMC-filter.
6	Hovedbryter.
7	Jordkopling.
8	Pumpens kabelkopling.

Instruksjoner for bruk

Starte styreenheten

Styreenheten startes ved å sette strømkabelen i veggkontakten og sett hovedbryteren i stilling 1.

Starte pumpen

Pumpen startes ved å trykke på knappen START.

Stoppe pumpen

Pumpen stoppes ved å trykke på knappen STOPP på frontpanelet.

Vedlikehold

Turbo-V 3K-T styreenheter er vedlikeholdsfrie. Alt arbeid på styreenheten må kun utføres av autorisert personell.

Dersom styreenheten stanser, må du ta kontakt med Agilents reparasjonsservice eller med Agilents avanserte bytteservice, som kan tilby overhalte styreenheter til erstatning for den ødelagte styreenheten.

ADVARSEL!

Før noe arbeid utføres på styreenheten, må den frakoples strømmettet.



Dersom en styreenhet skal kasseres, må dette skje i henhold til nasjonale bestemmelser.

Eliminering

Betydelsen av symbolet på logo "WEEE" på etikettene. Symbolet nedenunder som finnes, er anvendt i henhold til EC-direktiv kalt "WEEE". Dette symbolet (**som bare gjelder for land i Det europeiske fellesselskap**), viser at produktet som det sitter på, IKKE må behandles som vanlig hus-industriavfall, men må legges i kildesortering. Derfor oppfordrer man den sluttelige brukeren av anordningen å henvende seg til leverandøren av anordningen, som kan være et firma eller en forhandler, som sørger for oppsamling og eliminering etter å ha kontrollert avtal og betingelser i kjøpekontrakten.

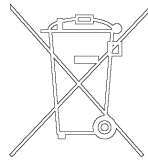

Feilmeldinger

Når det oppstår visse feil viser selvdiagnosekretsen i styreenheten den aktuelle feilmeldingen i displayet. De aktuelle feilmeldingen fremgår av tabellen nedenfor.

Tab. 1

MELDING	BESKRIVELSE	FORHOLDSREGEL
CHECK CONNECTION TO PUMP	Defekt kopling mellom pumpe og styreenhet.	Kontroller at tilkoplingskabelen mellom pumpe og styreenhet er skikkelig montert samt at kabelen ikke er skadet. Trykk to ganger på knappen START for å starte pumpen.
PUMP WAITING INTERLOCK	Låsesignalet for kontakt P1 skyldes en kortslutning mellom stift 3 og stift 8 i kontakten J1 eller fordi det eksterne låsesignalet er åpent.	Tilbakestill kortslutningen mellom stift 3 og stift 8 på kontakt J1 eller steng det eksterne låsesignalet.
FAULT: PUMP OVERTEMP.	Temperaturen på pumpens øverste lager er over 60 °C.	Vent til temperaturen synker under terskelverdien. Trykk to ganger på knappen START for å starte pumpen.
FAULT: CONTROLLER OVERTEMPERATURE	Temperaturen på styreenhetens transformator er over 90 °C.	Vent til temperaturen synker under terskelverdien. Trykk to ganger på knappen START for å starte pumpen.
FAULT: TOO HIGH LOAD	Ved normal drift har pumpen et strømforbruk som er høyere enn det som er programmert.	Kontroller om pumpens rotor kan rotere fritt. Trykk to ganger på knappen START for å starte pumpen.
FAULT: SHORT CIRCUIT	Ved normal drift (etter startmomentet) er utgangen kortsluttet.	Kontroller tilkoplingene mellom pumpe og styreenhet. Trykk to ganger på knappen START for å starte pumpen.

MELDING	BESKRIVELSE	FORHOLDSREGEL
OVERVOLTAGE	Det er en feil i styreenhetens forsyningsseksjon, eller styreenheten har mottatt et falsk signal.	Trykk to ganger på knappen START for å starte pumpen. Hvis meldingen dukker opp igjen, må du ta kontakt med Agilent for vedlikehold.
FLOW METER ALARM	Alarm for purgestrømmingen. Strømningsverdien har i 10 sekunder eller mer, blitt liggende på en verdi som er lavere enn innstilt terskel.	Kontroller at gassmatekretsen fungerer riktig.

9 Instruksjon Manual

Feilmeldinger



10 Ohjekäsikirja

Yleisiä tietoja	122
Varastointi	122
Valmistelut asennusta varten	123
Asennus	124
Käyttö	125
Valvojan Säätimet, Osoittimet ja Liittimet	126
Käyttötoimenpiteet	128
Valvojan käynnistys	128
Pumpun käynnistys	128
Pumpun pysäyttäminen	128
Huolto	128
Hävittäminen	129
Vianetsintä	130

Alkuperäisen ohjeiden käännös



Yleisiä tietoja

Tämä laite on tarkoitettu ammattimaiseen käyttöön. Ennen laitteen käyttöönottoa käyttäjän tulee lukea huolellisesti mukana seuraava käyttöohje sekä kaikki muut Agilentin toimittamat lisätiedot. Agilent ei vastaa seurauksista, jotka johtuvat laitteen käyttöohjeiden täydellisestä tai osittaisesta laiminlyömisestä, ammattitaidottomien henkilöiden suorittamasta laitteen virheellisestä käytöstä, valtuuttamattomista toimenpiteistä tai maakohtaisten säädösten ja normien vastaisesta käytöstä. Sarjan Turbo-V 3K-T valvojat ovat mikroprosessorien valvomia kiinteistä materiaaleista tehtyjä taajuudenmuuntimia, jotka kykenevät itsemäärittelyyn ja itsesuojaukseen.

Tämä ohjekirja käyttää seuraavia merkintöjä:

HUOMIO!

Huomio-merkinnät varoittavat toiminnoista, joiden laiminlyönti voi johtaa laitteen vaurioitumiseen.

VAROITUS!



Vaara-merkinnät saavat käyttäjän huomion kiinnittymään erityisiin toimintotapoihin, joiden seuraamatta jättäminen voi aiheuttaa vakavia henkilövaurioita.

HUOM

Huomiot sisältävät tärkeää tekstistä otettua tietoa.

Varastointi

Valvojan kuljetuksen ja varastoinnin aikana tulevat seuraavat ympäristövaatimukset olla täytettyinä:

- lämpötila: -20 °C ja +70 °C asteen välillä
- suhteellinen kosteus: 0 – 95 % (ilman lauhdetta)

Valmistelut asennusta varten

Valvoja toimitetaan erityisessä suojaavassa pakkauksessa. Mikäli havaitsette mahdollisesti kuljetuksen aikana tapahtuneita vaurioita, ottakaa yhteys paikalliseen myyntitoimistoon.

Pakkauksen purkamisen yhteydessä huolehtikaa, että valvoja ei pääse putoamaan ja välttäkää sen joutumista iskujen kohteeksi.

Älkää jättäkö pakkausta ympäristöön. Materiaali voidaan kokonaisuudessaan kierrättää ja se vastaa EU:n 85/399 direktiiviä ympäristön suojelusta.

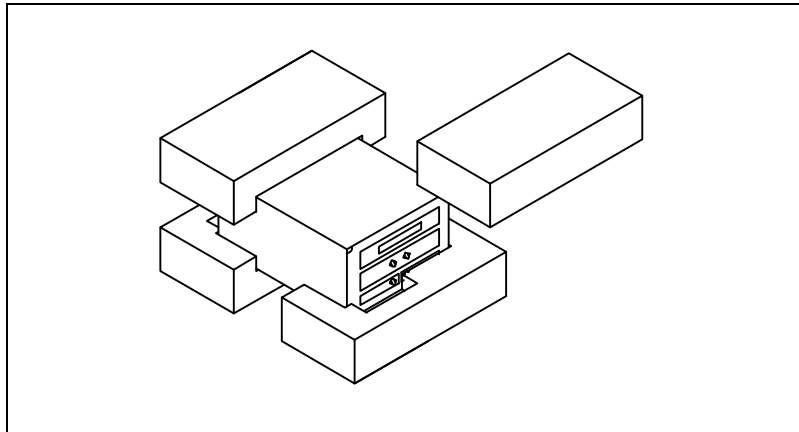

Kuva 1 Valvojan pakkaus

Jokainen valvoja on Agilentilla säädetty tietylle sähköjännitteelle:

- malli 869-9447 220 V:n vaihtovirrälle
- malli 869-9547 120 V:n vaihtovirrälle

Tarkistakaa, että valittu jännite on oikea ja kytkekää virtakaapeli uudelleen.

Asennus

VAROITUS!



Valvoja toimitetaan kolmijohtoisella sähkökaapelilla, jonka pistoke on kansainvälisesti hyväksytty. Käyttäkää aina tätä kaapelia ja asettakaa pistoke riittävästi maadoitettuun pistorasiaan, jotta sähköiskuilta vältytään. Valvojan sisällä syntyy korkeajännitettä, joka voi aiheuttaa vakavia vammoja tai jopa kuoleman. Ennen minkä tahansa valvojan huolto- tai asennustoimenpiteen suorittamista, irrottakaa valvoja sähköverkosta.

HUOM

Valvoja voidaan asentaa pöydän päälle tai siihen tarkoitukseen sopivan hyllyn sisään. Joka tapauksessa huolehtikaa siitä, että riittävä jäähdytysilma pääsee vapaasti kiertämään laitteen sisällä. Älkää asentako ja/tai käyttäkö valvojaa tiloissa, joissa se joutuu alttiiksi ympäristötekijöille (sade, jää, lumi), pölylle, syövyttävälle kaasulle, räjähdysalttiissa ympäristössä tai tiloissa, joissa paloriski on suuri.

Toiminnan aikana tulee noudattaa seuraavia ympäristöolosuhteita koskevia sääntöjä:

- lämpötila: 0 °C ja +40 °C välillä
- suhteellinen kosteus: 0 - 95% välillä (ilman lauhdetta)

Valvojaa kytkettäessä sille tarkoitettuun pumppuun käyttäkää valvojalle tarkoitettua erityiskaapelia.

Muiden kytkentöjen ja valinnaisten lisälaitteiden asennusten suorittamiseksi, katsokaa kappaletta "Tekniset tiedot".

Käyttö

Tähän kappaleeseen on kirjattu tärkeimmät käyttötoimenpiteet. Tarkempia lisätietoja sekä kytkentöjä ja valinnaisia lisälaitteita koskevien toimenpiteiden suorittamista käsitteleviä tietoja löydätte kappaleesta "Käyttö", joka on "Tekniset tiedot"- kappaleen liitteenä. Ennen valvojan käyttöä suorittakaa kaikki sähkökytkennät seuraten kytkettävän pumpun käyttöohjeita.

VAROITUS!



Mikäli pumppu on asetettu pöydälle, varmistakaa että se on vakaa. Näin vältetään vammoilta ihmisille sekä itse koneelle. Älkää myöskään käyttäkö pumppua, mikäli sisääntulon laippaa ei ole kytketty järjestelmään tai mikäli sitä ei ole suljettu laippasulkijalla.

HUOM

Sulkimen J1 liitin tulee jättää yhdyskaapelilla kytketyksi, mikäli ulkoisia kytkentöjä ei suoriteta. Esityhjiöpumppu ja Turbo-V-pumppu voidaan käynnistää samanaikaisesti.

Valvojan Säätimet, Osoittimet ja Liittimet

Seuraavassa on esitelty Valvojan valvontapaneeli ja yhteyspaneeli. Tarkempia lisätietoja saatte kappaleesta "Tekniset Tiedot".

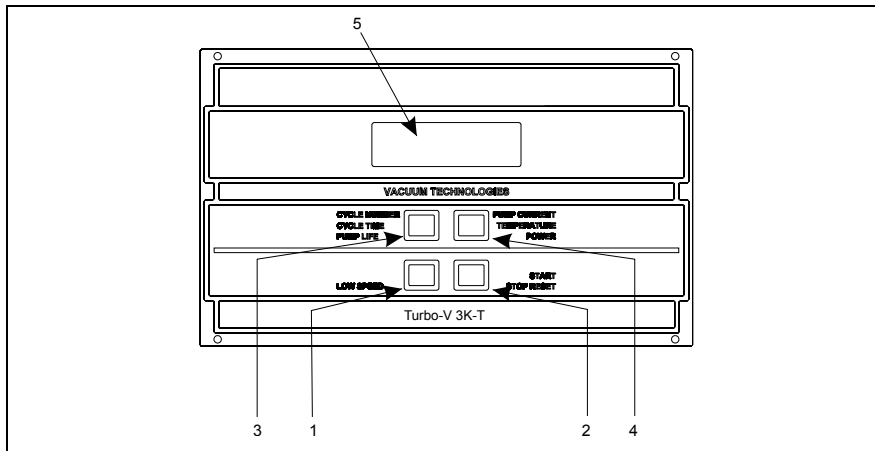

Kuva 2 Valvojen 869-9447 ja 869-9547 etupaneelit

1	HIGH/LOW SPEED -tilan valintapainonappi. Aktivoituu ainoastaan, kun valittuna on etupaneelin ohjaustila. Painettaessa painonappia toistuvasti siirrytään vaiheittain HIGH SPEED -tilasta LOW SPEED -tilaan.
2	KÄYNNISTYKSEN, PYSÄYTYKSEN JA UUDELLEENASETUKSEN käskyjen painonappi. Se aktivoituu ainoastaan, kun valittuna on etupaneelin toiminta-moodi. Yhden kerran painettaessa käynnistysvaihe aktivoituu. Uudelleen painettaessa pumppu pysähtyy. Mikäli pumppu on toimintahäiriön vuoksi pysähtynyt automaattisesti, painakaa painonappia yhden kerran, jolloin valvoja saadaan asetettua uudelleen. Toisen kerran painonappia painettaessa pumppu käynnistyy.
3	Painonappi, jonka avulla näyttöön saadaan kiertonumero, kiertoaika ja pumpun toiminta ja sarjanumero.
4	Painonappi, jonka avulla näyttöön ilmaantuvat pumpun sähkövirran, pumpun lämpötilan, pumpun tehon, kiertonopeuden, havaitun virtausarvon, kaasutyypin ja hälytystilan parametrit. Tämä on aina käytössä riippumatta valitusta toiminnosta. Painettaessa painonappeja 3 ja 4 vähintään kahden sekunnin ajan aktivoituu ohjelma, jonka avulla on mahdollista valita joitakin toimintaparametrejä.
5	Aakkosnumeerinen nestekidenäyttö : pistematriisi, 2 riviä x 16 merkkiä.

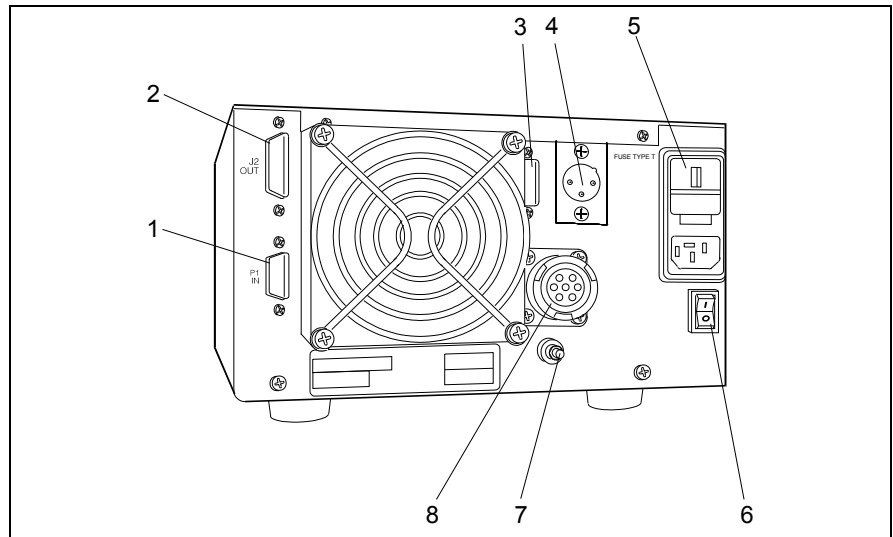

Kuva 3 Valvojen 869-9447 ja 869-9547 takapaneeli

1	Logiikkasignaalien tulokytkenä (pariliittimet toimitetaan niihin sopivilla yhdyskaapelisulkijalla).
2	Logiikkasignaalien poistokytkenä ja pumpun sähkövirran ja herätetaajuuden tarkistus.
3	Tila, joka on tarkoitettu viestintäportin sarjakytkennälle RS-232 – RS-485 (toimitetaan lisävarusteena).
4	Epäpuhtauksien poistoliitin.
5	Valvojan sähkövirran tulomoduuli. Käsittää suojasulakkeen, jännitteenmuuntajan, sähkövoiman pistorasian ja EMC suodattimen.
6	Virtakatkaisin.
7	Maadoitusliitäntä.
8	Pumpun kaapelin liitin.

Käyttötoimenpiteet

Valvojan käynnistys

Valvoja käynnistyy asetettaessa virtakaapeli pistorasiaan ja käännettäessä pääkatkaisin asentoon 1.

Pumpun käynnistys

Pumppu käynnistyy painettaessa START-painonappia.

Pumpun pysäyttäminen

Pumppu pysähtyy painettaessa etupaneelissa olevaa STOP-painonappia.

Huolto

Turbo-V 3K-T valvoja ei tarvitse huoltaa millään tavoin. Mahdolliset valvojaan tehtävät toimenpiteet tulee jättää aina valtuutetun henkilön tehtäviksi.

Toimintahäiriön sattuessa on mahdollista käyttää Agilentin korjauspalvelua tai "Agilent advance exchange service" -palvelua, jolloin on mahdollista vaihtaa rikkiöntunut valvoja ladattuun valvojaan.

VAROITUS!

Ennen minkä tahansa valvojaan tehtävän toimenpiteen suorittamista irrottakaa sähkökaapeli pistorasiasta.

Mikäli valvoja täytyy romuttaa, toimikaa sen hävittämisessä kansallisten säädösten ja normien määräämällä tavalla.

Hävittäminen

Pakkausmerkinnöissä olevan WEEE-logon merkitys. Alla näkyvä merkki on lisätty pakkaukseen EY:n ns. WEEE-direktiivin mukaisesti. Merkki (**koskee ainoastaan Euroopan Unionin jäsenmaita**) tarkoittaa, että tuotetta EI saa hävittää tavallisen kotitalous- tai teollisuusjätteen mukana, vaan se on toimitettava erilliseen keräyspisteeseen. Loppukäyttäjää kehoitetaan sen vuoksi ottamaan keräys- ja hävittämisprosessia varten yhteyttä laitteen toimittajaan, olipa se sitten laitteen valmistaja tai jälleenmyyjä, tarkastettuaan ensin kaupan sopimusehdot.

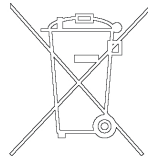

Vianetsintä

Joidenkin toimintahäiriöiden yhteydessä valvojan itsemäärittelypiiri analysoi virheen, joka näkyy viesteinä, jotka on kuvailtu seuraavassa taulukossa.

Tab. 1

VIESTI	VIKA	KORJAUSTOIMENPITEET
CHECK CONNECTION TO PUMP	Toimintahäiriö pumpun ja valvojan liitännässä.	Tarkistakaa, että pumpun ja valvojan välinen yhteyskaapeli on hyvin kiinnitetty päistään ja ettei siinä ole esteitä. Painakaa kaksi kertaa START-painonappia, jolloin pumppu käynnistyy.
PUMP WAITING INTERLOCK	Lukitussignaali (interlock) liittimessä P1 on aktiivinen johtuen liittimen J1 neurojen 3 ja 8 välillä tapahtuneen oikosulun keskeytyksestä tai ulkoisen lukitussignaalin (interlock) avautumisesta.	Palauttakaa liittimen J1 neurojen 3 ja 8 välinen oikosulku tai sulkekaa ulkopuolinen lukitussignaali (interlock).
FAULT: PUMP OVERTEMP.	Pumpun ylä lämpötila on ylittänyt 60 °C:ttä.	Odottakaa, että lämpötila palaa kynnysarvon alapuolelle. Painakaa START-painonappia kaksi kertaa, jolloin pumppu käynnistyy.
FAULT: CONTROLLER OVERTEMPERATURE	Valvojan muuntajan lämpötila on ylittänyt 90 °C:ttä.	Odottakaa, että lämpötila palaa kynnysarvon alapuolelle. Painakaa START-painonappia kaksi kertaa, jolloin pumppu käynnistyy.

VIESTI	VIKA	KORJAUSTOIMENPITEET
FAULT: TOO HIGH LOAD	Normaalityöskentelyn aikana (käynnistysvaiheen jälkeen) pumpun kuluttama sähkövirta on suurempi kuin sille on ohjelmoitu.	Tarkistakaa, että pumpun roottori pyörii vapaasti. Painakaa START-painonappia kaksi kertaa, jolloin pumppu käynnistyy.
FAULT: SHORT CIRCUIT	Normaalityöskentelyn aikana (käynnistysvaiheen jälkeen) poistoliitin on oikosulussa.	Tarkistakaa pumpun ja valvojan välinen liitos. Painakaa START-painonappia kaksi kertaa, jolloin pumppu käynnistyy.
OVERVOLTAGE	Valvojan sähköosastossa on jokin vika tai se on ottanut vastaan häiriösignaalin.	Painakaa START-painonappia kaksi kertaa, jolloin pumppu käynnistyy. Jos viesti ilmaantuu uudelleen, ottakaa yhteys Agilentiin huoltoa varten.
FLOW METER ALARM	Puhdistusvirtaukseen liittyvä hälytys. Virtausarvo on jäänyt asetettua kynnsarvoa alhaisemmaksi vähintään 10 sekunnin ajaksi.	Tarkista kaasun syöttöpiirin asianmukainen toiminta.

10 Ohjekäsikirja

Vianetsintä

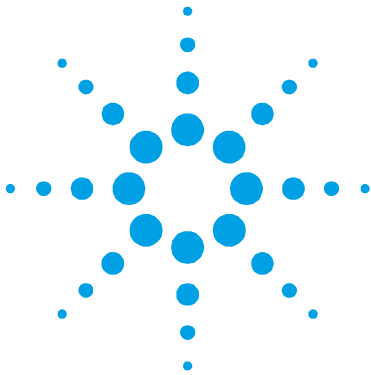

11 Felhasználói Kézikönyv

Általános információk	134
Tárolás	134
A telepítésre való előkészítés	135
Telepítés	136
Használat	137
A vezérlő parancsai, kijelzői és csatlakozói	138
Használati eljárások	140
A vezérlő bekapcsolása	140
A szivattyú beindítása	140
A szivattyú leállítása	140
Karbantartás	140
Megsemmisítés	141
Hibaüzenetek	142

Az eredeti utasítás fordítása



Általános információk

Ez a berendezés hivatásos használatra tervezett. A felhasználónak, a berendezés használatát megelőzően, gondosan el kell olvasnia e felhasználói kézikönyvet és minden egyéb, a Agilent által szolgáltatott információt. A Agilent elhárít magától minden esetleges felelősséget, mely a felhasználói utasítások teljes vagy részleges figyelmen kívül hagyásához, a nem kiképzett személyzet által történő nem megfelelő használathoz, meghatalmazás nélküli beavatkozásokhoz, vagy a specifikus nemzeti irányelvekkel ellentétes használathoz kötődik. A Turbo-V 3K-T sorozatú vezérlők mikroprocesszoros vezérlésű, szilárdtest-elemekkel realizált frekvencia-átalakítók, öndiagnosztikai és saját védelmi képességekkel.

E kézikönyv az alábbi megegyezésszerű jelöléseket alkalmazza:

FIGYELEM!

A figyelmeztető üzenetek azon eljárások előtt kerülnek megjelenítésre, melyek figyelmen kívül hagyása a berendezés károsodásához vezethet.

VESZÉLY!



A veszélyt jelző üzenetek olyan eljárásra vagy specifikus tevékenységre hívják fel a kezelő figyelmét, melyek, ha nem megfelelő módon kerülnek végrehajtásra, súlyos személyi sérüléseket okozhatnak.

MEGJEGYZÉS

A megjegyzések fontos, a szövegből kivonatolt információkat tartalmaznak.

Tárolás

A vezérlők szállítása és tárolása során az alábbi környezeti feltételeket kell biztosítani:

- hőmérséklet: -20 °C és +70 °C között
- relatív nedvességtartalom: 0 – 95 % (nem lecsapódó).

A telepítésre való előkészítés

A vezérlő speciális védőcsomagolásban kerül leszállításra; ha ez károsodás jeleit mutatja, melyek a szállítás során keletkezhetnek, kapcsolatba kell lépni a helyi forgalmazó irodával. A kicsomagolás során különleges figyelmet kell fordítani arra, hogy a vezérlő le ne essék, és ne szenvedjen ütődéseket. A csomagolóanyagot nem szabad szétszórni a környezetben. Az anyag teljes mértékben újrafelhasználható, s megfelel a környezetvédelemmel kapcsolatos EGK 85/399-es irányelvnek.

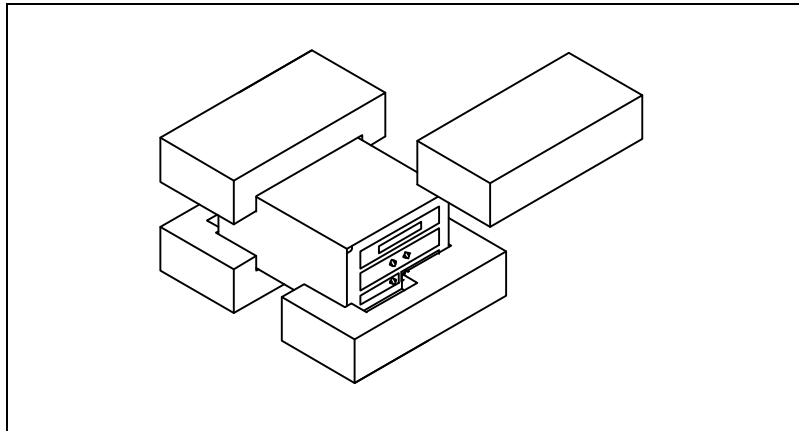

Ábra 1 A vezérlők csomagolása

Valamennyi vezérlő meghatározott tápfeszültségre előkészítve kerül a Agilent által leszállításra:

- a 869-9447 modell 220 Vac
- a 869-9547 modell 120 Vac

számára.

Ellenőrizendő, hogy a megfelelő feszültség került-e kiválasztásra, majd csatlakoztatni kell a hálózati kábelt.

Telepítés

VESZÉLY!



A vezérlő háromerű hálózati kábellel van ellátva, nemzetközileg jóváhagyott csatlakozódugóval. Mindig ezt a hálózati kábelt kell használni, s a csatlakozódugót megfelelő földcsatlakozóval ellátott aljzatba illeszteni, az elektromos kisülések elkerülése érdekében. A vezérlő belsejében nagyfeszültségek alakulnak ki, melyek súlyos károkat vagy halált okozhatnak. A vezérlő bármely telepítési vagy karbantartási műveletének megkezdése előtt ki kell húzni a hálózati csatlakozót.

MEGJEGYZÉS

A vezérlő telepítésre kerülhet egy asztalon, vagy egy megfelelő rack belsejében. Minden esetben szükséges azonban, hogy a hűtőlevegő szabadon áramolhasson a berendezés belsejében. A vezérlőt nem szabad légköri hatásoknak (eső, fagy, hó) kitett, poros, maró hatású gázt tartalmazó, robbanás- vagy fokozottan tűzveszélyes környezetben telepíteni vagy használni.

Üzem közben az alábbi környezeti feltételeket kell biztosítani:

- hőmérséklet: 0 °C és +40 °C között;
- relatív nedvességtartalom: 0 – 95 % (nem lecsapódó).

A többi összekötéssel és az opcionális kiegészítő felszerelések telepítésével kapcsolatosan lásd a "Technical Information" című alfejezetet.

Használat

Ebben a szakaszban a fontosabb működési eljárások kerülnek ismertetésre. További részletek és az összeköttéseket vagy az opcionális elemeket érintő eljárások találhatóak a “Technical Information” melléklet “Use” című szakaszában.

A vezérlő használata előtt valamennyi elektromos és pneumatikus összeköttetést létre kell hozni, és figyelembe kell venni a csatlakoztatott szivattyú kézikönyvét.

VESZÉLY!



Abban az esetben, ha a szivattyú egy asztalon került elhelyezésre, a személyekben és a berendezésben való károk elkerülése érdekében, biztosítani kell az asztal stabilitását. Soha nem szabad a szivattyút a bementi peremnek a rendszerhez való csatlakoztatása, vagy a záró peremmel való lezárása nélkül üzemeltetni.

MEGJEGYZÉS

A J1 lezáró csatlakozó össze kell maradjon kötve a megfelelő átkötéssel (jumper), ha nincs semmiféle külső összeköttetés. Az elő-vákuum és a Turbo-V szivattyú egyidejűleg is be lehetnek kapcsolva.

A vezérlő parancsai, kijelzői és csatlakozói

Az alábbiakban bemutatásra kerül a vezérlő kezelőpanelje és a csatlakozó panelek. További részletek találhatóak a “Technical Information” című szakaszban.

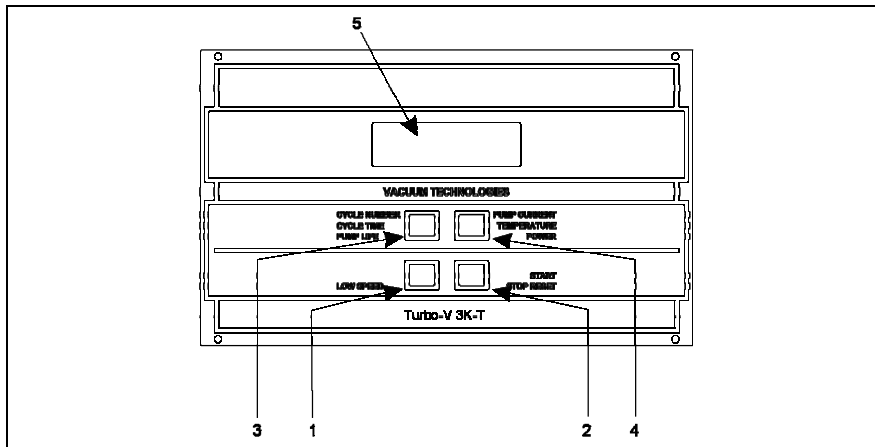

Ábra 2 A 869-9447-es és a 869-9547-as vezérlő előlapja

1	A HIGH/LOW SPEED (nagy/kis sebesség) üzemmód kiválasztására szolgáló nyomógomb. Csak akkor aktív, amikor az előlapról a parancsmód ki lett választva. Ismételt megnyomása ciklikusan vált a HIGH SPEED és a LOW SPEED között.
2	Nyomógomb a START, STOP vagy RESET parancsok indítására. Csak akkor aktív, amikor az előlapról a parancsmód ki lett választva. Egyszer megnyomva az indítási fázis kerül aktiválásra; még egyszer megnyomva a szivattyú leállításra kerül. Ha a szivattyú valamely hiba következtében automatikusan leáll, ezt a nyomógombot kell megnyomni; az első megnyomásra a vezérlő nullázódik (reset), a másodikra a szivattyú újraindul.
3	Nyomógomb a paramétereknek: ciklusszám, ciklusidő, szivattyú élettartama, a kijelzőre való lehívására és alkatrész kód.
4	Nyomógomb a paramétereknek: szivattyúáram, a szivattyú hőmérséklete, szivattyúteljesítmény, forgási sebesség, az érzékelt átfolyás értéke, a gáz típusa és a vészállapot kijelzőre való lehívására. Mindig aktív, függetlenül a kiválasztott üzemmódtól. A 3-as és 4-es nyomógombot együtt legalább 2 másodpercig nyomva tartva, egy program kerül aktiválásra, melynek segítségével kiválasztható néhány üzemi paraméter.
5	Folyadékkristályos alfanumerikus kijelző: pont-mátrixos, 2 sor x 16 karakter.

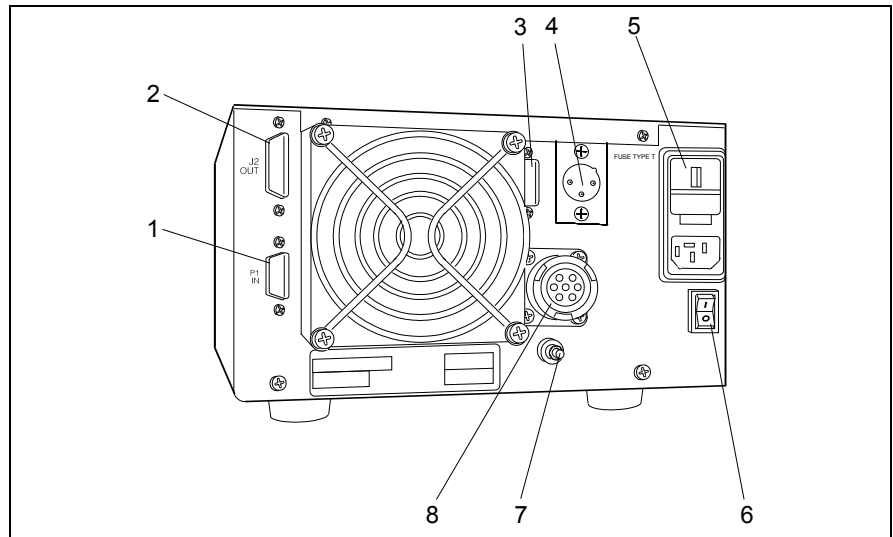

Ábra 3 A 869-9447-es és a 869-9547-as vezérlők hátlapja

1	Logikai jelek bemeneti csatlakozója (az összekötő csatlakozó megfelelő lezáró átkötéssel (jumper) van ellátva).
2	Logikai, és a szivattyú áramát valamint a gerjesztő frekvenciát ellenőrző jelek kimeneti csatlakozója.
3	Rekesz az RS 232 – RS 485 soros kommunikációs portok csatlakozói számára (opcióként szállítva).
4	Leengedő nyílás csatlakozója.
5	Bementei tápellátó modul, a vezérlő számára. Magában foglalja a védőbiztosítékot, a feszültségváltót, a tápfeszültség dugós csatlakozóját és az EMC-szűrőt.
6	Vonali megszakító.
7	Földösszeköttetés.
8	Szivattyúkábel csatlakozója.

Használati eljárások

A vezérlő bekapcsolása

A vezérlő bekapcsolásához elegendő a hálózati kábelt a hálózati aljzatba illeszteni és a vonali kapcsolót az 1. pozícióba hozni.

A szivattyú beindítása

A szivattyú beindításához meg kell nyomni az előlapon található START nyomógombot.

A szivattyú leállítása

A szivattyú leállításához meg kell nyomni az előlapon található STOP nyomógombot.

Karbantartás

A Turbo-V 3K-T sorozatú vezérlők semmiféle karbantartást sem igényelnek. Valamennyi beavatkozást meghatalmazott személyzet hajthat csak végre.

Meghibásodás esetén igénybe vehető a Agilent javítási szolgáltatása, vagy a "Agilent advanced exchange service", mely a meghibásodott helyett, egy javított vezérlőt biztosít.

VESZÉLY!



A vezérlőn való bármely beavatkozás végrehajtása előtt ki kell húzni a hálózati csatlakozót.

Amikor egy vezérlőt le kell selejtezni, megsemmisítésekor a tárgykörbe tartozó nemzeti normáknak megfelelően kell eljárni.

Megsemmisítés

A címkén jelenlévő "WEEE" logo jelentése. Az alább látható szimbólum az EK "WEEE" elnevezésű irányelvvel összhangban kerül alkalmazásra. Ez a szimbólum **(mely csak az Európai Közösség országaiban érvényes)**, azt jelzi, hogy a termék, melyen megtalálható, NEM kerülhet közöségi háztartási vagy ipari hulladékkal együtt megsemmisítésre, hanem azt egy szelektív hulladékgyűjtő rendszerbe kell továbbítani. A végfelhasználónak, a gyűjtési és megsemmisítési eljárás beindítása céljából, az adásvételi szerződés határidőinek és feltételeinek alapos áttanulmányozása után, fel kell vennie a kapcsolatot a berendezés szállítójával, legyen ez a gyártó vagy egy viszonteladó.

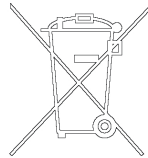

Hibaüzenetek

Néhány meghibásodási esetben a vezérlő öndiagnosztikai áramkörei hibaüzenetet jelenítenek meg (lásd az alábbi táblázatot).

Tab. 1

ÜZENET	LEÍRÁS	JAVÍTÁSI TEVÉKENYSÉG
CHECK CONNECTION TO PUMP	Összeköttetési hiba a szivattyú és a vezérlő között.	Ellenőrizni, hogy a szivattyú és a vezérlő közti összekötő kábel mindkét végén jól van-e rögzítve és nincs e megszakadva. A szivattyú újraindításához kétszer megnyomni a START nyomógombot.
PUMP WAITING INTERLOCK	A P1 csatlakozó reteszelés jelen jele aktív a J1 csatlakozó 3. és 8. pin-je közti rövidzár megszakadása, vagy a külső reteszelő jel nyitott állapota következtében.	Visszaállítani a J1 csatlakozó 3. és 8. pin-je közti rövidzárat, vagy zárni a külső reteszelő jelet.
FAULT: PUMP OVERTEMP.	A szivattyú felső csapágójának hőmérséklete meghaladta a 60 °C-t.	Várakozni, míg a hőmérséklet a küszöbérték alá esik. A szivattyú újraindításához kétszer megnyomni a START nyomógombot.
FAULT: CONTROLLER OVERTEMPERATURE	A vezérlő transzformátorának hőmérséklete túllépte a 90 °C-t.	Várakozni, míg a hőmérséklet a küszöbérték alá esik. A szivattyú újraindításához kétszer megnyomni a START nyomógombot.
FAULT: TOO HIGH LOAD	Normál üzem közben a szivattyú által felvett áram nagyobb a programozottnál.	Ellenőrizni, hogy a szivattyú forgórésze szabadon foroghat-e. A szivattyú újraindításához kétszer megnyomni a START nyomógombot.

ÜZENET	LEÍRÁS	JAVÍTÁSI TEVÉKENYSÉG
FAULT: SHORT CIRCUIT	Normál üzem közben (az indítási fázist követően) a kimeneti összeköttetés zárlatos.	Ellenőrizni az összeköttetéseket a szivattyú és a vezérlő között. A szivattyú újraindításához kétszer megnyomni a START nyomógombot.
OVERVOLTAGE	Meghibásodás történt a vezérlő tápellátási részegységében, vagy a vezérlő egy hamis jelet kapott.	A szivattyú újraindításához kétszer megnyomni a START nyomógombot. Ha az üzenet ismétlődik, a Agilent-től karbantartási beavatkozást kérni.
FLOW METER ALARM	A tisztítóáramhoz kapcsolódó vészjelzés. Az átáramló mennyiség, 10 másodpercig vagy azt meghaladó időtartamig a beállított küszöbérték alatt maradt.	Ellenőrizni a gáz tápláló körének helyes működését.

11 Felhasználói Kézikönyv

Hibaüzenetek

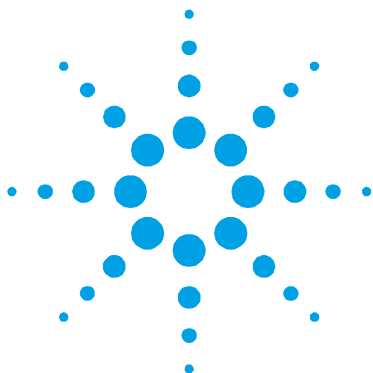

12 Podrecznik Instrukcji

Informacje ogólne	146
Magazynowanie	146
Przygotowanie do instalacji	147
Instalacja	148
Użytkowanie	149
Sterowniki, Wskazniki i Łączniki Kontrolera	150
Procedura użytkowania	152
Zaswiecenie kontrolera	152
Uruchomienie pompy	152
Zatrzymanie pompy	152
Konserwacja	152
Przetworstwo odpadów	153
Błędne informacje	154

Tłumaczenie instrukcji oryginalnej



Informacje ogólne

Urządzenie to jest przeznaczone do użytku zawodowego. Przed przystąpieniem do korzystania użytkownik powinien wnikliwie przesledzić zarówno ten podrecznik zawierający instrukcje jak również każda inna dostarczona przez Agilent informacje. Agilent uchyla się od jakiegokolwiek odpowiedzialności w przypadku całkowitego lub częściowego nie przestrzegania swoich instrukcji, przeznaczenia urządzenia niezgodnie z jego przeznaczeniem i jego obsługi przez personel uprzednio nie przeszkolony, naprawy urządzenia bez odpowiedniej autoryzacji lub przeznaczenia niezgodnego z obowiązującymi, specyficznymi normami krajowymi. Kontrolery z serii Turbo-V 3K-T są przetwornikami częstotliwości kontrolowanymi przez mikroprocesor zrealizowanymi z komponentów w stanie stałym i posiadającymi zdolności samodiagnostyczne i samoochronne.

Podrecznik ten opiera się na następujących konwencjach:

UWAGA!

Sygnały wzrokowe ukazujące się przed procedurą jeżeli zostaną zlekceważone mogą spowodować uszkodzenia urządzenia..

ZAGROZENIE!



Sygnały ostrzegające o zagrożeniu powinny zwrócić uwagę operatora na odpowiednią specyficzną procedurę którą jeżeli nie jest przestrzegana w sposób prawidłowy może przyczynić się do poważnych obrażeń osoby obsługującej.

PRZYPIS

Przypisy zawierają najważniejsze informacje wyciągnięte z tekstu.

Magazynowanie

Kontrolery podczas transportu i przechowywania w magazynie powinny mieć następujące warunki otoczenia:

- temperatura: od -20 °C do +70 °C
- wilgotność względna: od 0-95 %(nie kondensująca).

Przygotowanie do instalacji

Kontroler zostaje dostarczony w specjalnym, ochronnym opakowaniu; jeżeli opakowanie prezentuje jakiegokolwiek uszkodzenia które mogłyby powstać podczas transportu wówczas należy niezwłocznie powiadomić najbliższy, lokalny punkt sprzedaży.

Podczas operacji rozpakowywania należy zachować specjalną ostrożność żeby nie spowodować upadku kontrolera lub nie narazić na uderzenia. Nie wyrzucać opakowania ponieważ jest ono całkowicie recyklowalne i odpowiada normom CEE 85/399 dotyczącym ochrony środowiska.

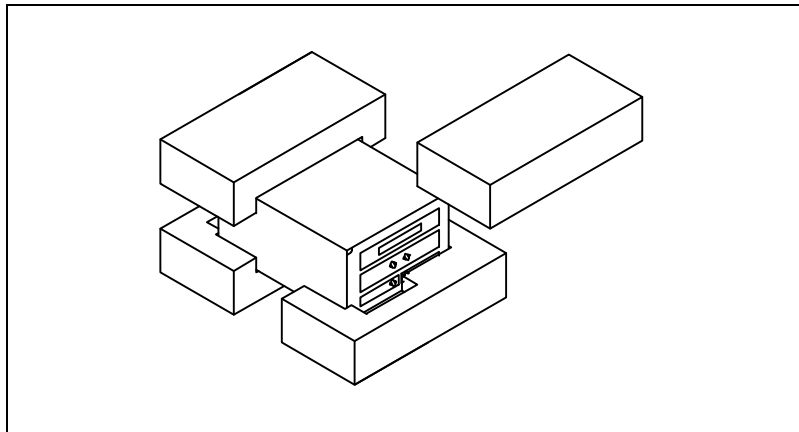

Posta 1 Opakowanie kontrolerów

Każdy kontroler dostarczony przez Agilent posiada już uregulowanie napięcia zasilania:

- model 869-9447 na 220 Vac
- model 869-9547 na 120 Vac

Sprawdź czy posiada prawidłowe napięcie i podłączyc kabel zasilania

Instalacja

ZAGROZENIE!



Kontroler jest zaopatrzony w kabel zasilający składający się z trzech przewodów i wtyczki odpowiadającej standardom międzynarodowym. Należy wyłącznie używać tego rodzaju kabla zasilającego i włączać wtyczkę do gniazdka posiadającego połączenie z masą celem wykluczenia iskrzen. We wnętrzu kontrolera powstają wysokie napięcia które mogą być przyczyną poważnych obrażeń lub wypadków śmiertelnych. Przed przystąpieniem do jakiegokolwiek operacji instalowania lub konserwacji należy odłączyć go od źródła zasilania.

PRZYPIS

Kontroler może być zainstalowany na stole lub wewnątrz odpowiedniego Rack. W obydwu przypadkach należy pamiętać aby wokół kontrolera zapewnić swobodny przepływ powietrza dla prawidłowego chłodzenia. Nie instalować i/lub użytkować kontrolerów w miejscach narazonych na działanie warunków atmosferycznych (jak deszcz, mroz, śnieg), pyłów, gazów agresywnych w środowisku wybuchowym lub o dużym stopniu zagrożenia pożarowego.

Podczas pracy kontrolera należy zapewnić następujące warunki otoczenia:

- temperatura: od 0 °C do +40 °C
- wilgotność względna: 0 – 95 % (nie kondensująca).

Do połączenia kontrolera z pompą należy używać jego specjalnego kabla.

Sposób połączenia i instalowania akcesoriów jest opisany w rozdziale "Technical Information".

Uzytkowanie

Paragraf ten zawiera podstawowe procedury operatywne. Dla uzyskania dodatkowych bardziej szczegolowych informacji lub dostepu do procedur na temat polaczen lub akcesoriow skonsultowac paragraf "Use" znajdujacy sie w dodatku do "Technical Information". Przed przystapieniem do uzytkowania kontrolera wykonac wszystkie polaczenia elektryczne i pneumatyczne podlaczenie pompy konsultowac z odnosa instrukcja.

ZAGROZENIE!



Kontroler Dla unikniecia obrazen personelu obslugujacego urzadzenie jak rowniez uszkodzen samego urzadzenia nalezy upewnic sie, szczegolnie w przypadku gdy pompa zostala ustawiona na stole, czy stol jest odpowiednio stabilny.Pod zadnym pozorem nie uruchamiac pompy jezeli kolnierz wejsciowy nie jest polaczony z systemem lub nie jest zamknieta kolnierzem zamykajacym.

PRZYPIS

W przypadku kiedy nie zostanie wykonane zadne polaczenie zewnetrzne lacznik zamykajacy J1 powinien pozostac polaczony ze swoim mostkiem.Pompa wstepnej prozni i pompa Turbo-V moga byc uruchomione jednoczesnie.

Sterowniki, Wskazniki I Laczniki Kontrolera

Ponizej jest przedstawiony pulpit sterowniczy kontrolera i pulpity polaczone. Dla uzyskania dokladniejszych szczegolow skonsultowac odpowiedni rozdzial "Technical Information".

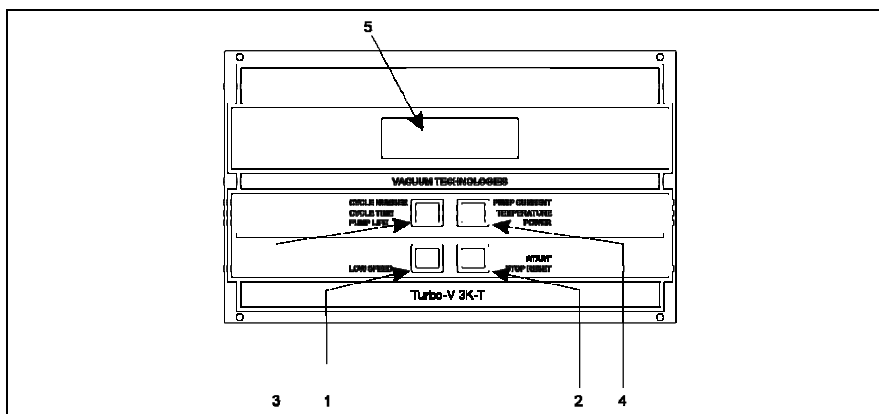

Posta 2 Pulpit frontany kontrolera 869-9447 e 869-9547

1	Przycisk do wybierania Przycisk do przesylnania sygnalu START, STOP LUB RESET. Dziala tylko wtedy kiedy sposob sterowania jest wybierany na pulpicie frontalnym naciskajac jeden raz uaktywnia sie faza uruchomienia; naciskajac ponownie zatrzymuje sie pompe. Jezeli pompa zatrzyma sie automatycznie z powodu uszkodzenia nalezy nacisnac przycisk jeden raz zeby zresetowac kontrolera I poraz drugi zeby uruchomic pompe.
2	Przycisk do przesylnania sygnalu START, STOP LUB RESET. Dziala tylko wtedy kiedy sposob sterowania jest wybierany na pulpicie frontalnym naciskajac jeden raz uaktywnia sie faza uruchomienia; naciskajac ponownie zatrzymuje sie pompe. Jezeli pompa zatrzyma sie automatycznie z powodu uszkodzenia nalezy nacisnac przycisk jeden raz zeby zresetowac kontrolera I poraz drugi zeby uruchomic pompe.
3	Pulsante per richiamare sul display i parametri cycle number, cycle time e pump life i numer serjiny.
4	Przycisk sluzacy do przywolania na display parametrov cycle number, cycle time I pump life Przycisk sluzacy do przywolania na display parametrov pump current., pump temperature, pump power I rotational speed.uzyskana wartosc przeplywu gazu i stan alarmowy. Jest zawsze aktywny niezaleznie od wybranego sposobu dzialania. Naciskajac jednoczesnie przyciski 3 I 4 przez conajmniej 2 sekundy uruchamia sie program przy pomocy ktorego jest mozliwe programowanie niektorych parametrov operatywnych.
5	Display alfanumeryczny na cieklych krysztalach: matryca punktowana, 2 linie x 16 czcionek.

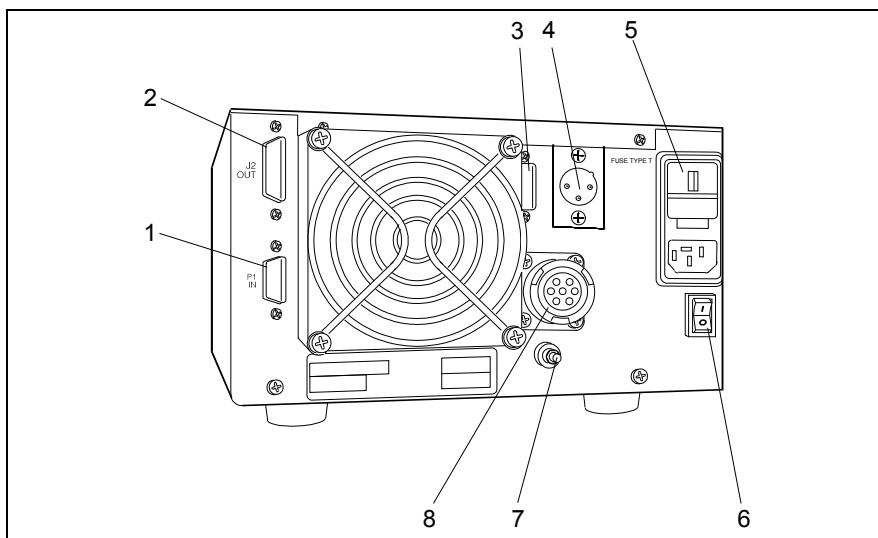

Posta 3 Tylny pulpit kontrolerow 869-9447 e 869-9547

1	Lacznik wejsciowy sygnalow logicznych (lacznik blizniaczy jest dostarczany z specjalnym mostkiem zamykajacym).
2	Lacznik wyjsciowy sygnalow logicznych i sprawdzania obecności prądu w pompie i częstotliwości pobudzenia.
3	Pomieszczenie przewidziane dla laczniaka wejsciowego komunikacji seryjnej RS-232 – RS-485 (dostarczany jako dodatkowy na zyczenie).
4	Łącznik ujścia odpowietrzającego.
5	Wejsciowy modul zasilania kontrolera zawiera bezpiecznik chroniaczy, zamiennik napiecia gniazdko wtyczkowe do zasilania mocy i filtr EMC.
6	Wylacznik linii.
7	Uziemienie.
8	Wejście dla kabla pompy.

Procedure uzytkowania

Zaswiecenie kontrolera

Do zaswiecenia kontrolera wystarczy wprowadzic kabel zasilajacy do gniazdka sieci sieciowego i przekrecic wylacznik do pozycji I.

Uruchomienie pompy

Do uruchomienia pompy wystarczy nacisnac przycisk START znajdujacy sie na pulpicie frontalnym.

Zatrzymanie pompy

Do zatrzymania pompy wystarczy nacisnac przycisk STOP znajdujacy sie na pulpicie frontalnym.

Konserwacja

Kontroler z serii Turbo-V 3K-T nie wymaga zadnej konserwacji.

Jakakolwiek interwencja moze byc dokonywana wylacznie przez osoby autoryzowane. W przypadku uszkodzenia mozliwe jest korzystanie z serwisow naprawczych Agilent lub "Agilent advance exchange service", w ktorym mozna otrzymac kontroler zregenerowany zastepujac go tym uszkodzonym.

ZAGROZENIE!



Przed wykonaniem jakiegokolwiek interwencji na kontrolerze nalezy odlaczyc kabel zasilajacy.

W przypadku decyzji zlomowania nalezy przeprowadzic operacje respektujac krajowe , specyficzne normy

Przetworstwo odpadów

Objasnienie znajdującego się na etykiecie znaczenia logo “WEEE”.

Użyty poniżej symbol jest zgodny z wymogiem zarządzenia “WEEE” Unii Europejskiej. Symbol ten (**prawomocny tylko w krajach Unii Europejskiej**) oznacza, że wyrob który nim został oznaczony NIE może być przetworzony jako odpad razem z innymi domowymi lub przemysłowymi natomiast musi być składowany w miejscu przeznaczonym dla odpadów do przerobki zroznicowanej . Dlatego też poleca się użytkownikowi, , po uprzedniej weryfikacji terminu i warunków zawartych w kontrakcie sprzedaży, nawiązać kontakt z dostawcą lub sprzedawcą urządzenia w celu uruchomienia procesu zbiórki i przerobu.

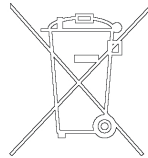

Bledne informacje

W niektórych przypadkach uszkodzen obwod do autodiagnozy kontrolera pokazuje blendne informacje przyklady sa wymienionee w ponizszej tabeli.

Tab. 1

INFORMACJA	OPIS	AKCJA KORYGUJACA
CHECK CONNECTION TO PUMP	Zaklozenia na polaczeniu miedzy pompa i kontrolerem.	Zweryfikowac czy kabel laczaczy pompe z kontrolerem jest dobrze zamocowany na obydwu koncach I czy nie jest przerwany. Nacisnac dwa razy przycisk START dla ponownego uruchomienia pompy.
PUMP WAITING INTERLOCK	Jest aktywny sygnal Interlock na laczniku P1 spowodowany zwarcieciem pomiedzy pin 3 I pin 8 lacznika J1, Lub na skutek otwarcia sygnalu zewnetrznego interlock.	Dokonac naprawy obwodu elektrycznego pomiedzy pin 3 i pin 8 lacznika J 1 lub zamknac sygnal interlock zewnetrzny.
FAULT: PUMP OVERTEMP.	Temperatura gornego lozyska lub pompy przekroczyła 60 °C.	Odczekac az temperatura sie obnizy ponizej ustalonego poziomu. Nacisnac dwa razy przycisk START dla ponownego uruchomienia pompy
FAULT: CONTROLLER OVERTEMPERATURE	Temperatura transformatora w kontrolerze przekroczyła 90 °C.	Odczekac az temperatura sie obnizy ponizej ustalonego poziomu. Nacisnac dwa razy przycisk START dla ponownego uruchomienia pompy.
FAULT: TOO HIGH LOAD	Podczas normalnej pracy (po fazie rozruchu) zuzycie pradu przez pompe jest wieksze od zaprogramowanego.	Sprawdzic czy wirnik nie ma przeszkod w swobodnym obrocie. Nacisnac dwa razy przycisk START dla ponownego uruchomienia pompy.

INFORMACJA	OPIS	AKCJA KORYGUJACA
FAULT: SHORT CIRCUIT	Podczas normalnej pracy (po fazie uruchomienia) na wyjściu sa zwarcia.	Sprawdzic polaczenie pompy z kontrolerem. Nacisnac dwa razy przycisk START dla ponownego uruchomienia pompy.
OVERVOLTAGE	Nastapilo uszkodzenie w sekcji zasilania kontrolera lub kontroler otrzymal sygnal nieprawidlowy.	Nacisnac dwa razy przycisk START dla ponownego uruchomienia pompy. Jezeli sygnal sie powtorzy zwrocic sie do Agilent o przeprowadzenie konserwacji.
FLOW METER ALARM	Sygnal alarmowy dotyczacy przeplywu strumienia przeczyszczajacego. Wartosc strumienia pozostala na poziomie nizszym od ustalonego progu i osiagnela szybkość wieksza/rowna 10 second.	Skontrolowac prawidlowe funkcjonowanie obwodu zasilania gazu.

12 Podrecznik Instrukcji

Bledne informacje

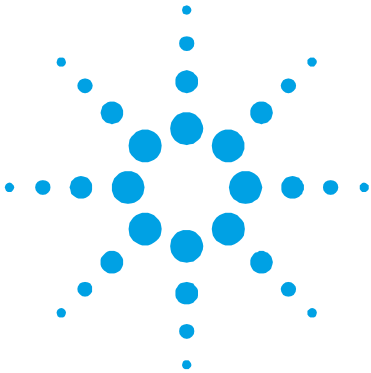

13 Návod k Použití

Všeobecné informace	158
Uskladnění	158
Příprava k instalaci	159
Instalace	160
Použití	161
Ovládání, indikátory a konektory Kontroléru	162
Používané procedury	164
Zapalování Kontroléru	164
Spouštění čerpadla	164
Zastavení čerpadla	164
Údržba	164
Likvidace	165
Chybné zprávy	166

Překlad originálního návodu



Všeobecné informace

Tento přístroj je určen pro profesionální potřebu. Uživatel si musí před použitím tuto příručku velmi pozorně přečíst, ale i každou další aktualizaci, kterou podnik bude předávat. V důsledku nedostatečného i částečně nesprávného použití, nebo v případě chyb nevyškoleného personálu či neoprávněných zásahů a neodpovídajících specifickým státním normám, Agilent nepřijímá a nenesí žádnou zodpovědnost.

Kontroléry série Turbo-V 3K-T jsou frekvenčními konvertory, jsou kontrolovány mikroprocesorem a skládají se z pevných komponentů s autodiagnostickou a samoochrannou schopností.

Tato příručka používá následující označení:

POZOR!

Tyto zprávy bývají vizualizovány před jakoukoliv procedurou, je třeba se jimi řídit, aby nedošlo k poškození přístroje.

NEBEZPEČÍ!



Odkazy, které upozorňují na nebezpečí a donutí operátora, aby se řídil dle procedury nebo specifické praktiky, která nebude-li řádně vykonána, může ohrozit vážným způsobem jeho zdraví.

POZNÁMKA

Poznámky, vyjmuté z textu obsahují velmi důležité informace.

Uskladnění

Během dopravy a skladování kontrolérů, se musí dbát na následující podmínky prostředí:

- teplota: od -20 °C do +70 °C
- relativní vlhkost: 0 – 95 % (nesmí kondenzovat).

Příprava k instalaci

Kontrolér je dodáván v speciálním ochranném balení; objeví-li se následkem dopravy nějaké poškození, je třeba se okamžitě obrátit na místní prodejní servis. Během rozbalování se obzvláště musí dávat pozor, aby kontrolér nespadol nebo aby neutrpěl nárazy. Balicí materiál se nesmí odkládat v přírodě. Tento materiál se může kompletně recyklovat, neboť se shoduje se směrnicemi EU, CEE 85/399, které se týkají životního prostředí.

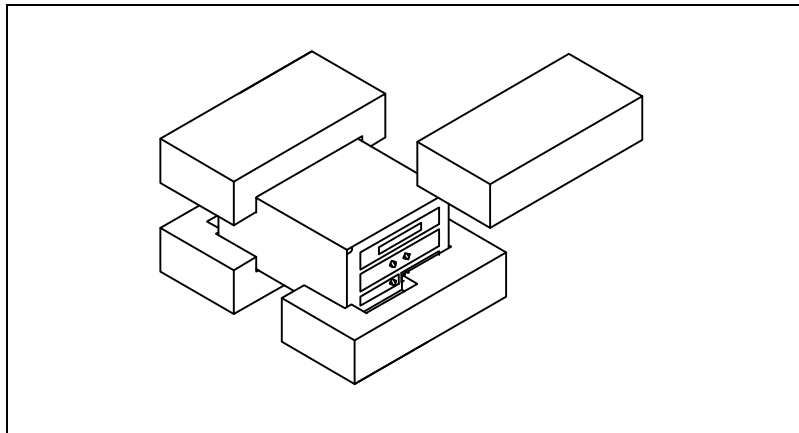

Postava 1 Obal kontrolérů

Každý kontrolér, dodaný podnikem Agilent, je připraven na jisté elektrické napětí:

- model 869-9447 pro 220 Vac
- model 869-9547 pro 120 Vac

Provéřít, zda bylo zvoleno správné napětí a kabel musí být napojen na elektrickou síť.

Instalace

NEBEZPEČÍ!



Kontrolér má napájecí kabel se třemi dráty a zástrčku shodnou s mezinárodním standardem. Výše uvedený kabel musíte používat neustále i zástrčku zasunovat do zásuvky s adekvátně uzeměným spojením, aby nevznikaly elektrické výboje. Uvnitř kontroléru dochází k vysokým napětím, která jsou velmi nebezpečná i smrtící. Před provedením jakékoliv instalační či údržbové operace s kontrolérem, je třeba ho odpojit od elektrického příkonu.

POZNÁMKA

Kontrolér může být nainstalován na stole nebo uvnitř příslušného rack. V každém případě je třeba, aby okolo přístroje mohl vzduch volně proudit. Kontrolér se nesmí instalovat v místech vystavených atmosferickým vlivům (déšť, mráz, sníh), prachu, agresivním plynům, na výbušných místech nebo na místech kde existuje velké riziko požárů.

Během provozu je třeba, aby se respektovaly následující podmínky, týkající se operativního prostředí:

- teplota: od 0 °C do +40 °C
- Relativní vlhkost: 0 – 95 % (nesmí kondenzovat).

Aby se kontrolér mohl napojit na relativní čerpadlo, je třeba použít specifický kabel, který je přidán k samotnému kontroléru.

Pro ostatní napojení a instalaci opčního příslušenství se obrátit na sekci "Technical Information".

Použití

V tomto odstavci jsou uvedené hlavní operativní postupy. Pro ostatní detaily a pro postupy, které se vztahují na napojení, anebo na zvolené příslušenství, postupovat dle odstavce "Use" v dodatku "Technical Information".

Před použitím kontroléru je třeba vykonat veškerá potřebná elektrická a pneumatická napojení, při čemž je třeba se obracet na příručku napojeného čerpadla.

NEBEZPEČÍ!



Aby se vyhnulo nebezpečí, které může ohrozit osoby i přístroj, musí se zkontrolovat jeho stabilita v případě, že čerpadlo je položené na stole. Jestliže vstupní příruba není napojená na systém nebo není uzavřena se zavírací přírubou, čerpadlo se nesmí spustit do provozu.

POZNÁMKA

Uzavírací konektor J1, jestliže nebude uskutečněno žádné vnější spojení, musí zůstat propojený se svým můstkem. Čerpadla pre-prázdná a Turbo-V se mohou zapnout současně.

Ovládání, indikátory a konektory Kontroléru

V následujícím je ilustrován ovládací pult kontroléru a panely vzájemných propojení. Pro širší detaily je třeba se obrátit na sekci "Technical Information".

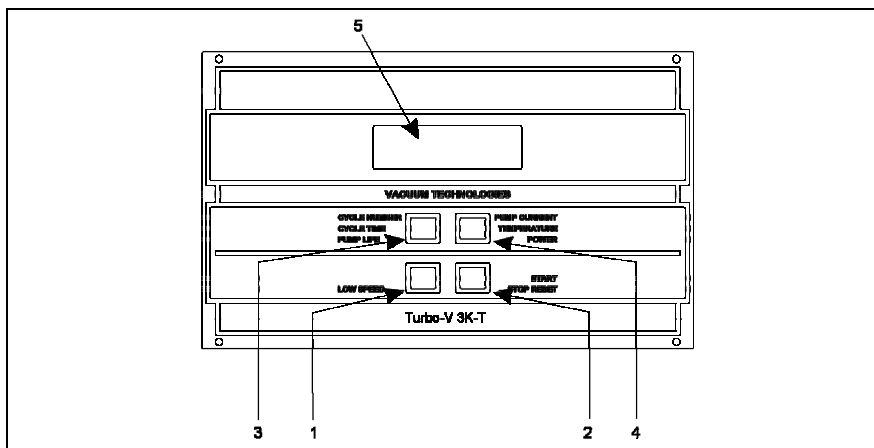

Postava 2 Čelný panel "Kontroléru" 869-9447 a 869-9547

1	Tlačítko na volbu HIGH/LOW SPEED. Je aktivní jen při zvoleném způsobu ovládání z čelního panelu. Několikerým stisknutím se přechází z HIGH SPEED do LOW SPEED.
2	Tlačítko ovládání START, STOP nebo RESET. Je aktivním jen po volbě na čelním panelu. Stiskne-li se jen jednou, spouštěcí fáze bude aktivována; jestliže se znovu stiskne, čerpadlo se zastaví. Jestliže se čerpadlo automaticky zastaví z důvodu nějaké poruchy, tlačítko se musí napoprvé stisknout, aby se uskutečnil reset kontroléru a po druhé aby se čerpadlo znovu spustilo.
3	Tlačítko na přivolání parametrů na displeji: cycle number, cycle time a pump life a pořadové číslo.
4	Tlačítko na přivolání parametrů na displeji: pump current, pump temperature, pump power, rotational speed, hodnoty zjištěného toku, druhu plynu a nouzového stavu. Nezávisle od zvoleného provozního způsobu, je neustále aktivní. Společným stisknutím tlačítek 3 a 4 na alespoň 2 sekundy, bude aktivován program, dle kterého se mohou naprogramovat některé operativní parametry.
5	Alfanumerický displej na tekuté krystaly: bodová matice, 2 linky x 16 charakterů.

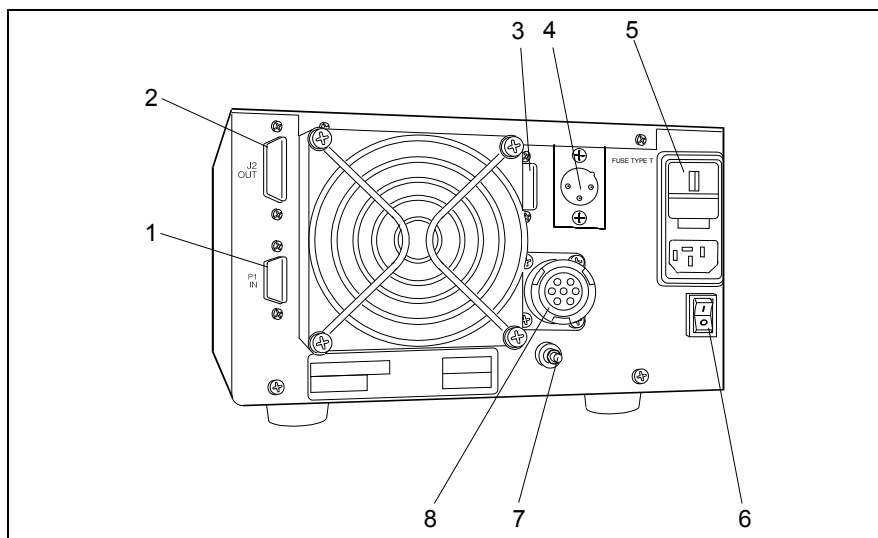

Postava 3 Zadní panel Kontroléru 869-9447 a 869-9547

1	Vstupní konektor logických signálů (spojovací konektor se dodává s příslušným uzavírajícím můstkem.).
2	Výstupní konektor logických signálů a kontroly elektrického proudu čerpadla a budícího kmitočtu.
3	Místo předurčené na konektor komunikačních seriálních dveří RS-232 – RS-485 (opční dodávka).
4	Výpustný konektor.
5	Vstupní modul napájení pro Kontrolér. Obsahuje ochrannou pojistku, meniče napětí, napájecí zásuvku výkonu a filtr EMC.
6	Síťový vypínač.
7	Uzemnění.
8	Konektor kabelu čerpadla.

Používané procedury

Zapalování Kontroléru

Kontrolér se zapne vložením kabele do zásuvky na síti a vypínač přepnout na polohu 1.

Spouštění čerpadla

Čerpadlo se spustí stisknutím tlačítka START na čelním panelu.

Zastavení čerpadla

Čerpadlo se zastaví stisknutím tlačítka STOP na čelním panelu.

Údržba

Kontroléry série Turbo-V 3K-T nevyžadují žádnou údržbu. Jakýkoliv zásah musí vykonat jen pověřený personál.

V případě poruchy se může využít opravářského servisu Agilent nebo "Agilent advanced exchange service", kde poškozený kontrolér bude vyměněn za nový.

NEBEZPEČÍ!



Nejdříve, před jakýmkoliv zásahem na kontroléru, se musí odpojit elektrický kabel.

Bude-li zapotřebí kontrolér likvidovat, musí se postupovat dle platných specifických státních norem.

Likvidace

Význam loga "WEEE" nacházejícího se na štítku. Níže uvedený symbol odpovídá směrnici CE pojmenovaným "WEEE". Tento symbol (**platný jen pro státy Evropské Unie**) určuje, že výrobek, který je takto označen NESMÍ být likvidován společně s ostatními domácími nebo průmyslovými odpady, ale je nutno ho předat do patřičných provozních sběrů, kde musí být tříděn a likvidován odděleně od městského odpadu. Uživateli, který má výrobek likvidovat doporučujeme, aby se nakontaktoval přímo s výrobcem nebo prodejcem, který se po patřičném prověření termínů a smluvních podmínek postará o kompletní likvidaci uvedeného výrobku.

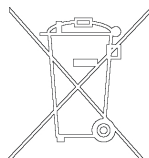

Chybné zprávy

V některých případných poruchách na autodiagnostických obvodech, kontrolér předává několik chybných odkazů, které jsou vyjmenovány v tabulce, která se nachází na následující stránce.

Tab. 1

ZPRÁVY	POPIS	KOREKCE
CHECK CONNECTION TO PUMP	Nefunguje napojení mezi čerpadlem a kontrolérem.	Provéřit zda kabelové spojení mezi pumpou a kontrolérem je správně upevněné na obou dvou koncích a že nedošlo k přerušení. Stisknout tlačítko START dvakrát pro opětné spuštění čerpadla.
PUMP WAITING INTERLOCK	Aktivní signál interlock se nachází na konektoru P1, neboť došlo k přerušení zkratu mezi pin 3 a pin 8 del konektoru J1, nebo kvůli otevření signálu vnějšího interlock.	Znovu obnovit spojení nakrátko mezi pin 3 a pin 8 konektoru J1, nebo uzavřít signál vnějšího interlock.
FAULT: PUMP OVERTEMP.	Teplota horního ložiska čerpadla překročila 60 °C.	Počkat až se teplota opět vrátí pod mezní hodnotu. Stisknout dvakrát tlačítko START pro opětné spuštění čerpadla.
FAULT: CONTROLLER OVERTEMPERATURE	Teplota transformátora kontroléru překročila 90 °C.	Počkat až se teplota opět vrátí pod mezní hodnotu. Stisknout dvakrát tlačítko START pro opětné spuštění čerpadla.
FAULT: TOO HIGH LOAD	Během normálního provozu spotřeba proudu čerpadla je vyšší než ta naprogramovaná.	Provéřit, zda se může rotor čerpadla volně otáčet. Stisknout dvakrát tlačítko START pro opětné spuštění čerpadla.
FAULT: SHORT CIRCUIT	Během normálního provozu výstupní spojení se nachází ve zkratu.	Provéřit propojení mezi čerpadlem a kontrolérem. Stisknout dvakrát tlačítko START pro opětné spuštění čerpadla.

ZPRÁVY	POPIS	KOREKCE
OVERVOLTAGE	Vznikla porucha v napájecí sekci kontroléru, nebo kontrolér dostal falešný signál.	Stisknout dvakrát tlačítko START pro opětné spuštění čerpadla. Po opětné zprávě, z důvodu údržby je nutné se obrátit na Agilent.
FLOW METER ALARM	Alarm vztahující se na tok purge. Hodnota toku zůstala oproti hodnotě nastavené na nižší hodnotě po dobu vyšší nebo rovnající se 10 vteřinám.	Zkontrolovat, zda plynový napájecí obvod funguje správně.

13 **Návod k Použití** Chybné zprávy

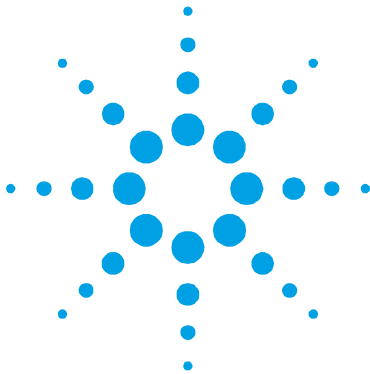

14 Návod na Obsluhu

Všeobecné informácie	170
Uskladnění	170
Príprava pre inštaláciu	171
Inštalácia	172
Použitie	173
Povely, Ukazovatele a Prípojky "Controller"	174
Postup pri použití	176
Zapnutie "Controller"	176
Naštartovanie čerpadla	176
Zastavenie čerpadla	176
Údržba	176
Likvidácia	177
Oznamy väd	178

Preklad originálneho návodu



Všeobecné informácie

Tento prístroj slúži k profesionálnemu použitiu. Užívateľ si pred použitím tohto prístroja musí pozorne prečítať tento návod k použitiu a jeho ďalšie doplnky, dodané podnikom Agilent. Podnik Agilent nepreberá na seba žiadnu zodpovednosť za úplné, alebo čiastočné nedodržanie návodu, za nesprávne používanie prístroja nekompetentnými osobami, za nepovolené zásahy a za používanie, ktoré nie je v zhode s príslušnými národnými normami. “Controllers” série Turbo-V 3K-T sú meniči kmitočtu, kontrolované mikroprocesorom, vyrobené prvkami pevnej fázy a so schopnosťou samodiagnostiky a samokontroly.

Tento návod používa nasledujúce signály:

POZOR!

Signály “pozor” sú pred tými postupmi, ktoré, v prípade ich nedodržania, môžu poškodiť prístroj.

NEBEZPEČIE!



Signál nebezpečie upozorňuje pracovníka na určitý pracovný postup, ktorý, keď nie je prevedený správne, môže zapríčiniť vážne osobné poranenia.

POZNÁMKA

Poznámky zahrňujú dôležité informácie, vytiahnuté z textu.

Uskladňovanie

Počas prepravy a uskladňovania “Controllers” musia byť dodržané tieto podmienky prostredia:

- teplota: od -20 °C do +70 °C
- relatívna vlhkosť: 0 – 95 % (bez kondenzátu).

Príprava pre inštaláciu

“Controller” je dodaný v špeciálnom ochrannom obale; keby ste objavili škodu, spôsobenú prepravou, skontaktujte sa s kanceláriou miestneho predaja. Pri rozbal'ovaní dávajte pozor, aby vám “Controller” nespadol, alebo niekde nenarazil. Obal nezahadzujte. Je vyrobený z recyklovateľného materiálu a zodpovedá smernici CEE 85/399 pre ochranu životného prostredia.

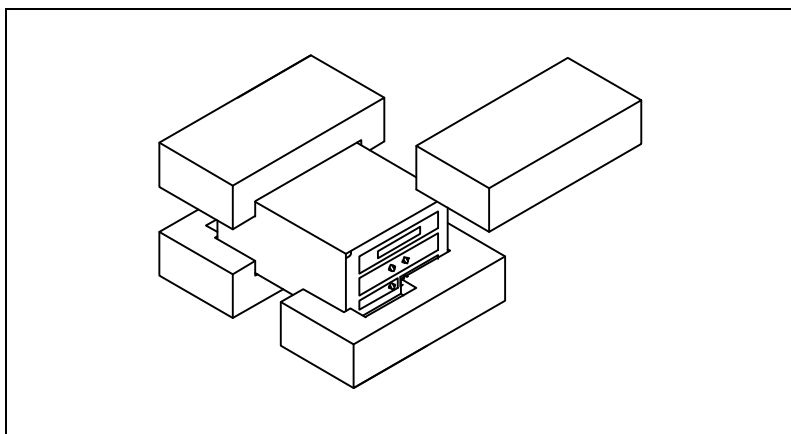

Postava 1 Obal “Controllers”

Každý “Controller”, dodaný firmou Agilent je prispôsobený na určité napätie:

- model 869-9447 pre 220 Vac
- model 869-9547 pre 120 Vac

Skontrolujte, či bolo zvolené správne napätie a len potom napojte na elektrinu.

Inštalácia

NEBEZPEČIE!



“Controller” je dodaný s trojdrôtovým napájacím káblom a so zástrčkou, ktorá zodpovedá medzinárodnej úrovni. Používajte vždy iba tento napájací kábel a zástrčku zasúvajte do zásuvky, ktorá má vhodné uzemnenie, aby ste sa vyhli elektrickému výboju. Vo vnútri “Controller” sa vytvára vysoké napätie, ktoré môže spôsobiť vážne škody alebo smrť. Pred akýmkoľvek úkonom, týkajúceho sa inštalácie alebo údržby “Controller” nezabudnite vytiahnuť zástrčku z elektrickej zásuvky.

POZNÁMKA

“Controller” musí byť inštalovaný na pracovnom stole alebo vo vnútri príslušnej kovovej skrine. V každom prípade je potrebné, aby chladiaci vzduch mohol voľne krúžiť okolo prístroja. “Controller” nepoužívajte a neinštalujte v prostredí, vystavenom atmosferickým vplyvom (dážď, mráz, sneh), prachu, agresívnym plynom a v prostredí s vysokým rizikom požiaru.

Počas chodu je dôležité, aby boli rešpektované tieto podmienky prostredia:

- teplota: od 0 °C do +40 °C;
- relatívna vlhkosť: 0 – 95 % (nekondenzovaná).

Pre napojenie “Controller” na príslušné čerpadlo použite jeho príslušný kábel.

Pre ostatné napojenia a inštaláciu zvoliteľného príslušenstva vid' časť "Technical Information".

Použitie

V tomto odstavci sú uvedené hlavné operatívne postupy. Pre ostatné detaily a pre postupy, ktoré sa vzťahujú na napojenia, alebo na zvolené príslušenstvo, postupujte podľa časti "Use" v dodatku "Technical Information".

Pred použitím "Controller" preveďte všetky potrebné elektrické a pneumatické napojenia a riadte sa podľa návodu napojeného čerpadla.

NEBEZPEČIE!



Aby ste sa vyhli osobnému nebezpečeniu a poškodeniu prístroja, skontrolujte, aby čerpadlo, umiestnené na pracovnom stole bolo stabilné. Čerpadlo nikdy nenašartujte vtedy, keď vstupná príruha nie je napojená na systém, alebo nie je zavretá s uzáverovou prírubou.

POZNÁMKA

Uzavierajúca prípojka J1 sa musí nechať napojená na jej mostík vtedy, keď nie je prevedené žiadne vonkajšie napojenie. Pred-prázdňové čerpadlo a čerpadlo Turbo-V môžu byť zapnuté súčasne.

Povely, Ukazovatele a Prípojky "Controller"

Dolu je znázornený ovládací panel "Controller" a panely medzinapojenia. Pre ďalšie detaily konzultuje časť "Technical Information".

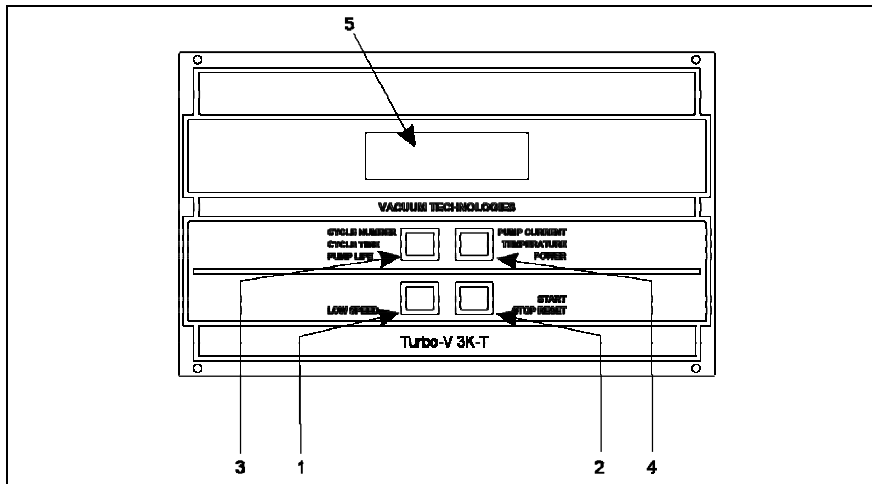

Postava 2 Čelný panel "Controller" 869-9447 e 869-9547

1	Tlačidlo pre voľbu HIGH/LOW SPEED. Je aktívne iba vtedy, keď povel vychádza z čelného panelu. Držiac ho stále stlačený, sa cyklicky prechádza z HIGH SPEED do LOW SPEED.
2	Tlačidlo povelov ŠTART, STOP alebo RESET. Je aktívne iba vtedy, keď povel vychádza z čelného panelu. Keď sa stlačí raz, spustí sa fáza naštartovania; stlačiac ho znovu sa zastaví čerpadlo. Keď sa čerpadlo v prípade poruchy zastaví automaticky, treba stlačiť toto tlačidlo prvýkrát pre resetovanie "Controller" a druhýkrát pre znovunaštartovanie čerpadla.
3	Tlačidlo pre vyvolanie parametrov cycle number, cycle time a pump life na displej a poradové číslo.
4	Tlačidlo pre vyvolanie parametrov pump current, pump temperature, pump power, rotational speed, hodnoty zisteného toku, druhu plynu a núdzového stavu na displeji. Je stále aktívny, nezávisle od voľby funkcie. Stlačiac spolu tlačidlá 3 a 4 na aspoň 2 sekundy, sa spustí program, s ktorým je možné zvoliť niektoré operatívne parametre.
5	Alfanumerický displej na tekutý kryštál: bodová matica, 2 línie x 16 písmen.

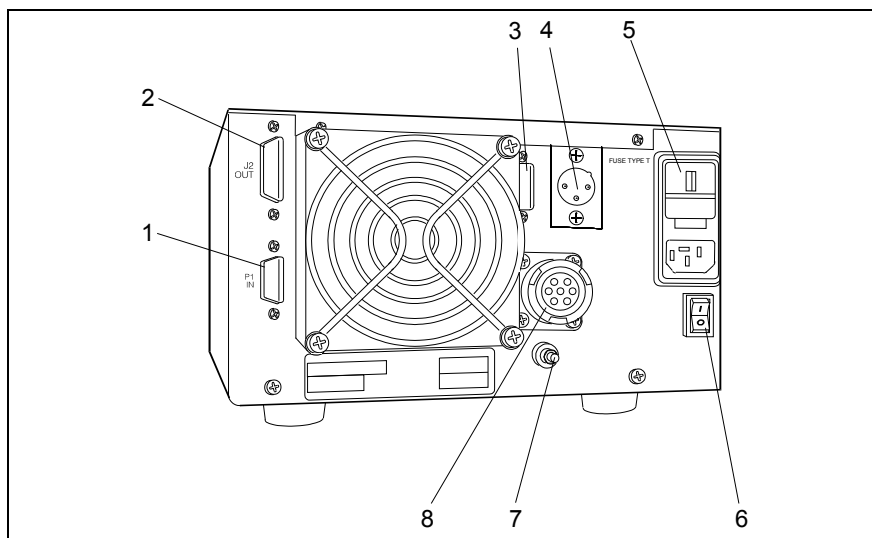

Postava 3 Zadný panel "Controller" 869-9447 e 869-9547

1	Vstupná spojka logických signálov (spojovacia spojka je doganá s príslušným uzavierajúcim mostíkom.).
2	Spojka výstupu logických signálov a kontroly elektrického prúdu čerpadla a budiaceho kmitočtu.
3	Miesto určené pre spojku hradlového obvodu pre seriálnu komunikáciu RS-232 – RS-485 (dodaný na požiadavku).
4	Výpustný konektor.
5	Vstupný modul napájania pre "Controller". Má v sebe ochrannú poistku, menič napätia, napájaciu zásuvku výkonu a filter EMC.
6	Vypínač siete.
7	Uzemnenie.
8	Spojka pre kábel čerpadla.

Postup pri použití

Zapnutie "Controller"

Pre zapnutie "controller" stačí zapojiť kábel na elektrickú sieť a vypínač siete dať do polohy 1.

Naštartovanie čerpadla

Pre naštartovanie čerpadla treba stlačiť tlačidlo START na čelnom paneli.

Zastavenie čerpadla

Pre zastavenie čerpadla treba stlačiť tlačidlo STOP na čelnom paneli.

Údržba

"Controllers" série Turbo-V 3K-T nevyžadujú žiadnu údržbu. Akýkoľvek zásah musí previesť poverený personál.

V prípade vady je možné využiť opravnú službu Agilent alebo "Agilent advanced exchange service", ktorá vymení vadný "controller".

NEBEZPEČIE!



Pred akýmkoľvek zásahom na "controller" vytiahnite šnúru z elektrickej siete.

V prípade, že "controller" musí ísť do zberu, riad'te sa platnými príslušnými národnými normami.

Likvidácia

Význam loga "WEEE" nachádzajúceho sa na štítkoch. Aplikovanie doluo značeného symbolu dodržiava smernicu EÚ s názvom "WEEE". Tento symbol (**platný iba pre štáty Európskej Únie**) znamená, že výrobok s týmto štítkom NEMIE byť odstránený spolu s bežným domácim alebo priemyselným odpadom, ale sa musí odstrániť ako delený odpad. Vyzývame preto konečného užívateľa, aby sa skontaktoval s dodávateľom prístroja, či už je to výrobca alebo predajca za účelom jeho likvidácie podľa zmluvných podmienok predaja.

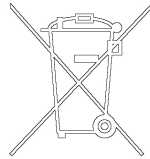

Oznamy vąd

V niektorých prípadoch, týkajúcich sa vąd, obvod samodiagnostiky “controller” signalizuje niekoľko oznamov vąd, uvedených na ďalšej strane.

Tab. 1

OZNAM	POPIS	ZÁSAAH OPRAVY
CHECK CONNECTION TO PUMP	Nefunguje napojenie medzi čerpadlom a “controller”.	Skontrolujte, či je spojovací kábel medzi čerpadlom a “controller” správne zasunutý na oboch koncoch a či nie je prerušený. Stlačte dvakrát tlačidlo START pre znovunaštartovanie čerpadla.
PUMP WAITING INTERLOCK	je aktívny signál interlock na spojke P1 z dôvodu prerušenia skratu medzi pin 3 a pin 8 spojky J1, alebo z dôvodu otvorenia signálu vonkajšieho interlock.	Obnoviť skrat medzi pin 3 a pin 8 spojky J1, alebo zavrieť signál vonkajšieho interlock.
FAULT: PUMP OVERTEMP.	Teplota horného ložiska čerpadla prekročila 60 °C.	Počkať, kým teplota neklesne pod hranicu. Stlačte dvakrát tlačidlo START pre znovunaštartovanie čerpadla.
FAULT: CONTROLLER OVERTEMPERATURE	Teplota transformátora “controller” prekročila 90 °C.	Počkať, kým teplota neklesne pod hranicu. Stlačte dvakrát tlačidlo START pre znovunaštartovanie čerpadla.
FAULT: TOO HIGH LOAD	Počas bežného chodu spotreba prúdu čerpadla je vyššia ako spotreba naprogramovaná.	Skontrolujte, či má rotor čerpadla možnosť točiť sa voľne. Stlačte dvakrát tlačidlo START pre znovunaštartovanie čerpadla.
FAULT: SHORT CIRCUIT	Počas bežného chodu (po naštartovaní) východzie napojenie je v skrate.	Skontrolujte napojenia medzi čerpadlom a “controller”. Stlačte dvakrát tlačidlo START pre znovunaštartovanie čerpadla.

OZNAM	POPIS	ZÁSAH OPRAVY
OVERVOLTAGE	Objavila sa vada v sekcii napájania "controller", alebo "controller" dostal falošný signál.	Stlačte dvakrát tlačidlo START pre znovunaštartovanie čerpadla. Keď sa tento oznam objaví znovu, obráťte sa na firmu Agilent pre údržbu.
FLOW METER ALARM	Alarm, vzťahujúci sa na tok purge. Hodnota toku zostala pod nastavenou hodnotou na dobu vyššiu, alebo rovnajúcu sa 10.-tim sekundám.	Skontrolujte, či obvod napájania plynu funguje správne.

14 **Návod na Obsluhu**

Oznamy vád



15 Priročnik za Navodila

Splošne informacije	182
Skladiščenje	182
Priprava za montažo	183
Montaža	184
Uporaba	185
Komande, indikatorji in konektorji Controllera	186
Postopki uporabe	188
Vklonitev Controllera	188
Zagon črpalke	188
Zaustavitev črpalke	188
Vzdrževanje	188
Odlaganje odpadkov	189
Obvestilo o napaki	190

Prevod navodil v izvirniku



Splošne informacije

Naprava je namenjena samo za strokovno rabo. Uporabnik mora temeljito prebrati priročnik in pri tem upoštevati vsako dodatno informacijo, ki jo nudi Agilent. Agilent ne odgovarja v slučaju celotnega ali delnega nespoštovanja navodil, pri nepravilni uporabi s strani nestrokovnega osebja, v slučaju nedovoljenih posegov ali pri zanemarjenju specifičnih nacionalnih meril. Controller serije Turbo-V 3K-T je frekvenčni pretvornik, na katerega nadzor ima mikrokrmilnik, sestavljen iz solidnih delov za katere so značilne lastnosti avtodiagnoze in avtozaščite.

V tem priročniku so varnostne informacije razvrščene v dva razreda:

POZOR!

Znak 'pozor' se pojavi pred postopke, ki če jih uporabnik zanemari, lahko napravo poškoduje.

SVARILO!



Znak svarila opozarja uporabnika, da mora pri določenem postopku ali pri posebnem delovanju paziti. Kršitev svarila lahko privede do lažjih ali hudih telesnih poškodb.

OPOMBA

Opombe vsebujejo vse najbolj pomembne informacije iz besedila.

Skladiščenje

Med prevozom in skladiščenjem controllerjev morate zagotoviti naslednje pogoje okolice:

- temperatura: od -20 °C do +70 °C
- relativna vlaga: 0 – 95 % (bez kondenzacije).

Priprava za montažo

Controller dobite v posebni zaščitni embalaži; če so na embalaži znaki poškodbe, ki naj bi nastale med transportom obrnite se krejavnemu prodajalnemu biroju. Pri odstranitvi embalaže morate še posebno paziti, da controller ne pade na tla ali da ne podleigne udarcem. Ne zavržite embalaže v okolico. Material lahko v celoti reciklirate in ustreza direktivi CEE 85/399 za zaščito okolja.

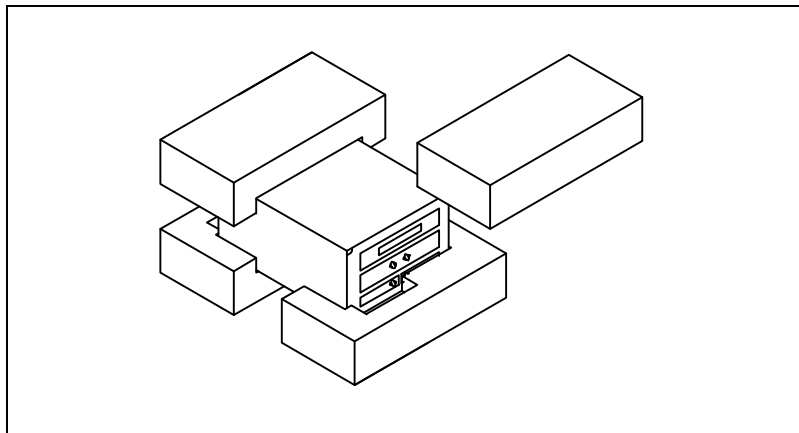

Slika 1 Embalaža controllerjev

Vsak Controller Agilent je napravljen za določeno napajalno napetost:

- model 869-9447 za 220 Vac
- model 869-9547 za 120 Vac

Preverite, da ste izbrali pravilno napetost in ponovno priključite napajalni kabel.

Montaža

SVARILO!



Controller ima napajalni vod s tremi žicami in vtikač priznan na mednarodni ravni. Uporabljajte vedno ta napajalni kabel in vtikač vtaknite v vtičnico z ustreznim masovnim vezanjem, ker drugače vas lahko strese električni tok. Znotraj controller-jev se stvori visoka napetost, ki lahko človeku povzroči hude poškodbe ali celo smrt. Preden bi nadaljevali s katerokoli dejavnostjo montaže ali vzdrževanja controllera, izklopите controller iz vtičnice.

OPOMBA

Controller lahko montirate na mizo ali vgradite v notranjost ustreznega rack-a. V vsakem slučaju morate poskrbeti, da voda za hlajenje prosto kroži skozi napravo. Controller-a ne smete montirati ali uporabiti v okolici, ki je izpostavljena klimatskim dejavnikom (dežju, ledu, snegu), prahu, agresivnim plinom, v okolici kjer obstaja nevarnost vnetja ali požara.

Med delovanjem morate zagotoviti naslednje pogoje okolice:

- temperatura: od 0 °C do +40 °C;
- relativna vlaga: 0 – 95 % (ne-kondezna).

Za priključitev controllera s črpalko uporabite kabel, ki spada k controlleru

Za ostale priključke in montažo drugih dodatnih delov, si lahko ogledate poglavje "Technical Information".

Uporaba

V tem odstavku so navedeni glavni operativni postopki. Podrobnejše informacije in postopke, ki zadevajo priključitve in ostale opcije najdete v paragrafu "Use" v priponki "Technical Information".

Preden bi vključili controller, morate zagotoviti da boste priključili vse električne in pnevmatske kable, pri tem pa si oglejte priročnik priložene črpalke.

SVARILO!

Da bi se izognili poškodbam bodisi oseb kot naprave, morate poskrbeti, da ste črpalko stabilno položili (če ste jo vgradili na mizi). Črpalka ne sme nikoli delovati, če vhodna prirobnica ni priklopljena k sistemu ali če ni zaprta s zapiralno prirobnico.

OPOMBA

Konektor za zapiranje J1 mora ostati priključen k svojemu mostičku, če niste izvršili nikakršne druge zunanje priključitvije. Črpalko predhodnega črpanja in črpalko Turbo-V lahko istočasno vklopite.

Komande, indikatorji in konektorji Controllera

Spodaj prikaz komandne plošče Controllera in interkonektorske plošče. Za podrobnejše informacije si oglejte paragraf "Technical Information".

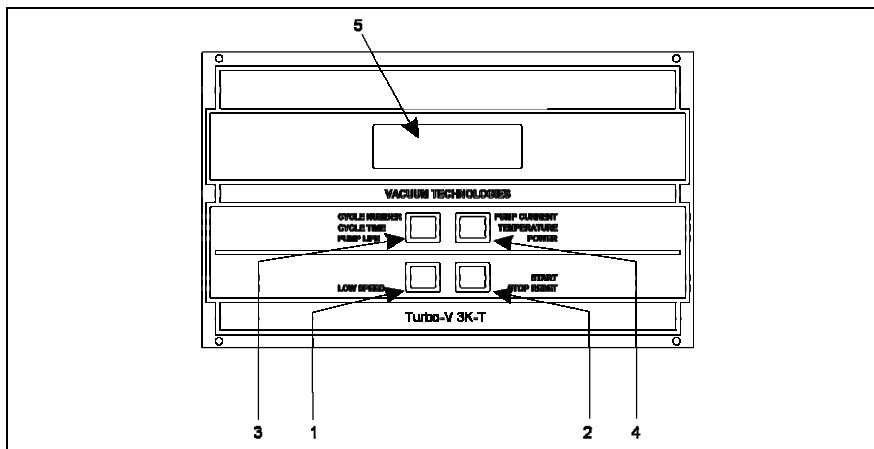

Slika 2 Prednja plošča Controllera 869-9447 e 869-9547

- | | |
|---|---|
| 1 | Tipka za LOW SPEED modus je aktivna samo nato, ko ste izbrali to komando iz prednje plošče. Če gumb enkrat pritisnete, črpalka se vrti za 2/3 nominalne vrednosti. Če še enkrat pritisnete gumb, izključite LOW SPEED modus. |
| 2 | Tipka za zagon komand START, STOP ali RESET. Aktivna je samo nato, ko ste to komando nastavili na prednji plošči. Če gumb enkrat pritisnete boste pognali črpalko; če ga še enkrat pritisnete, boste črpalko zaustavili. Če se je črpalka sama zaustavila zaradi kvara, morate to tipko enkrat pritisniti, da bi lahko controller-a resetirali in še drugič za ponoven zagon črpalke. |
| 3 | Tipka za preklic na zaslonu parametrov cycle number, cycle time in pump life, registrska številka. |
| 4 | Tipka za preklic na zaslonu parametrov pump current, pump temperature, pump power, rotational speed, vrednost posnetega toka, vrsta plina in stanje alarma. Vedno je aktivna neodvisno od nastavljenega delovanja tipke. Če skupaj pritisnete tipki 3 in 4 za vsaj 2 sekundi boste aktivirali program, s katerim lahko nastavite nekaj operativnih programov. |
| 5 | Alfaštevilčni zaslon od tekočih kristalov: prebija bodov, 2 linije x 16 znakov. |

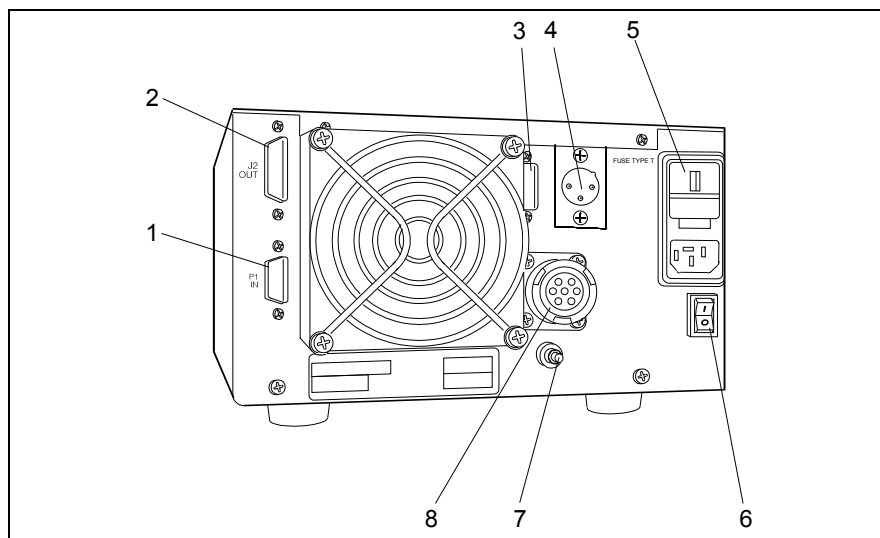

Slika 3 Ozadnja plošča controllerjev 869-9447 e 869-9547

1	Vhodni konektor logičnih signalov (spajalni z ustreznim zapiralnim mostičkom).
2	Izhodni konektor logičnih signalov in za preveritev toka črpalke in frekvence razburljivosti.
3	Odprtina za konektor komunikacijskih serijskih vrat RS-232 – RS-485 (kot opcija).
4	Čistilni konektor.
5	Vhodni napajalni modul Controller-a. Vsebuje zaščitno varovalko, menjalca napetosti, močno napajalno vtičnico in filter EMC.
6	Linjsko stikalo.
7	Ozemljitev.
8	Konektor za kabel črpalke.

Postopki uporabe

Vklopitev Controllera

Za vklopitev Controller-a morate napajalni kabel vtakniti v omrežno vtičnico in namestiti linijsko stikalo na položaj 1.

Zagon črpalke

Za zagon črpalke morate pritisniti gumb START na prednji plošči.

Zaustavitev črpalke

Za zaustavitev črpalke pritisnite tipko STOP na sprednji plošči.

Vzdrževanje

Controllerji serije Turbo-V 3K-T ne potrebujejo vzdrževanja. Samo pooblaščen osebje lahko rokuje s to napravo.

V slučaju okvare obrnite se servisu Agilent ali "Agilent advanced exchange service", ki Vam bo dal na razpolago obnovljeni controller.

SVARILO!

Pred katerikoli posegom, izklopite iz controller-a. napajalni kabel



Controller zavrzite kot industrijski odpadek v skladu z državnimi predpisi.

Odlaganje odpadkov

Pomen znamke "WEEE" na etiketah. Spodaj navedeni simbol je v skladu z direktivo ES znano pod imenom "WEEE". Ta simbol (**ki velja samo v državah Evropske Skupnosti**) pomeni, da izdelek NE SMETE ODSTRANITI skupaj z ostalimi komunalnimi ali pa industrijskimi odpadki, temveč morate poskrbeti za njihovo primerno ločevanje. Zato pozivamo uporabnike, da se ali pri prodajalnem centru ali pa pri prodajalcu seznanijo o postopku ločevanja in odstranitve odpadkov, šele nato, ko se je seznanil s pogoji in z merili kupopordajne pogodbe.

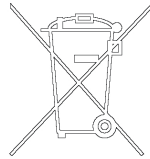

Obvestilo o napaki

V nekaterih slučajih kvara, vezje avtodiagnoze controllera pokaže nekaj obvestil o napakah kot so prikazane v tabeli na naslednji strani.

Tab. 1

OBVESTILO	OPIS	POPRAVA
CHECK CONNECTION TO PUMP	Napaka v delovanju priključitve črpalke in controllera	Preverite, da je priključni kabel med črpalko in controllerjem na obeh koncih trdno pričvrščen in da ni prekinjen. Dvakrat pritisnite tipko START za ponoven zagon črpalke.
PUMP WAITING INTERLOCK	Signal interlocka prisoten na konektoju P1 zaradi prekinitve kratkega stika med pinom 3 in pinom 8 konektorja J1, ali ker se je odprl signal zunanjega interlocka.	Ponovno nastavite kratki stik med pinom 3 in pinom 8 konektorja J1, ali zaprite signal zunanjega interlocka.
FAULT: PUMP OVERTEMP.	Temperatura gornjega ležišča ali črpalke je presegla $60\text{ }^{\circ}\text{C}$.	Počakajte, da se temperatura vrne pod normalnim vrednostnim pragom. Pritisnite dvakrat tipko START za ponoven zagon črpalke.
FAULT: CONTROLLER OVERTEMPERATURE	Temperatura transformatorja controllera je presegla $90\text{ }^{\circ}\text{C}$.	Počakajte, da se temperatura vrne pod normalnim vrednostnim pragom. Dvakrat pritisnite tipko START za ponoven zagon črpalke.
FAULT: TOO HIGH LOAD	Med navadnim delovanjem (po zagonu) je tok, ki ga črpalka črpa večji od nastavljenega.	Preverite, da lahko rotor črpalke prosto vrti. Dvakrat pritisnite tipko START za ponoven zagon črpalke.
FAULT: SHORT CIRCUIT	Med navadnim delovanjem (po zagonu) je priklopitev na izhodu v kratkem stiku.	Preverite priključke črpalke in controllera. Dvakrat pritisnite tipko START za ponoven zagon črpalke.

OBVESTILO	OPIS	POPRAVA
OVERVOLTAGE	Kvar v oddelku za napajanje controllera, ali je controller dobil nepristen znak.	Dvakrat pritisnite tipko START za ponoven zagon črpalke. Če se to obvestilo spet pojavi, obrnite se Agilent za pravilno vzdrževanje.
FLOW METER ALARM	Alarm glede toka purge. Vrednost toka je manjša od nastavljenega vrednostnega praga, za daljše ali isto obdobje od 10 sekund.	Preverite, da napajalno vezje plina dobro deluje.

15 Priročnik za Navodila
Obvestilo o napaki

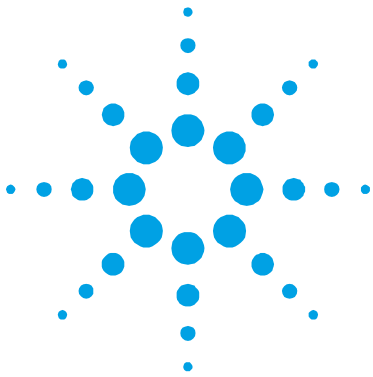

16 Instructions for Use

General information	194
Storage	194
Preparation for installation	195
Installation	196
Use	197
Controller Controls, Indicators and Connectors	198
Use procedure	200
Controller Startup	200
Starting the Pump	200
Pump Shutdown	200
Maintenance	200
Disposal	201
Error Messages	202

Original Instructions



General information

This equipment is intended for use by professionals. The user should read this instruction manual and any other additional information supplied by Agilent before operating the equipment. Agilent will not be held responsible for any events occurring due to non-compliance, even partial, with these instructions, improper use by untrained people, non-authorized interference with the equipment or any action contrary to that provided for by specific national standards. The Turbo-V 3K-T Rack Controller are microprocessor-controlled, solid-state, frequency converters with self-diagnostic and self-protection features.

This manual uses the following conventions:

CAUTION!

The caution messages are displayed before procedures which, if not followed, could cause damage to the equipment.

WARNING!



The warning messages are for attracting the attention of the operator to a particular procedure or practice which, if not followed correctly, could lead to serious injury.

NOTE

The notes contain important information taken from the text.

Storage

When transporting and storing the controllers, the following environmental requirements should be satisfied:

- temperature: from -20 °C to + 70 °C
- relative humidity: 0 – 95 % (without condensation)

Preparation for installation

The controller is supplied in a special protective packing. If this shows signs of damage which may have occurred during transport, contact your local sales office. When unpacking the controller ensure that it is not dropped or subjected to any form of impact. Do not dispose of the packing materials in an unauthorized manner. The material is 100 % recyclable and complies with EEC Directive 85/399.

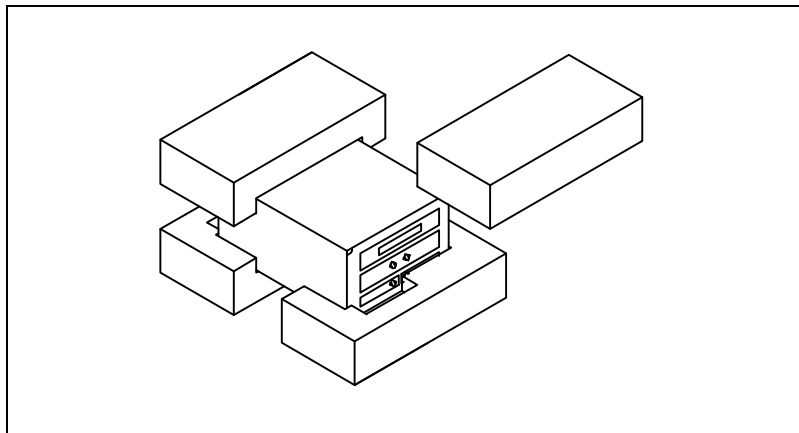

Figure 1 Controllers packing

Each controller is factory set for a specific power supply:

- model 869-9447 is factory set for 220 Vac operation
- model 869-9547 is factory set for 120 Vac operation

Check voltage selector window for correct set and connect power cord.

Installation

WARNING!



The Turbo-V controller is equipped with a 3-wire power cord and plug (internationally approved) for user safety. Use this power cord and plug in conjunction with a properly grounded power socket to avoid electrical shock. High voltage developed in the controller can cause severe injury or death. Before servicing the unit, disconnect the input power cable.

NOTE

The Turbo-V controller can be used as a bench unit or a rack module, but it must be positioned so that free air can flow through the holes. Do not install or use the controller in an environment exposed to atmospheric agents (rain, snow, ice), dust, aggressive gases, or in explosive environments or those with a high fire risk.

During operation, the following environmental conditions must be respected:

- temperature: from 0 °C to +40 °C;
- relative humidity: 0 – 95 % (without condensation).

To connect the controller to the pump use the specific cable supplied with the controller.

See the appendix “Technical Information” for detailed Information about the above mentioned and the other connections, and about the options installation.

Use

This paragraph describes the fundamental operating procedures. Detailed information and operating procedures that involve optional connection or option are supplied in the paragraph “USE” of the appendix “Technical Information”. Make all vacuum manifold and electrical connections and refer to Turbo-V pump instruction manual before operating the Turbo-V controller.

WARNING!



To avoid injury to personnel and damage to the equipment, if the pump is laying on a table make sure it is steady. Never operate the Turbo-V pump if the pump inlet is not connected to the system or blanked off.

NOTE

The input signal J1 connector should be left in position including the shipping links if no external connections are made. The forepump and Turbo-V pump can be switched on at the same time.

Controller Controls, Indicators and Connectors

The following paragraph illustrates the Controller control panel and interconnection panel. More details are contained in the appendix "Technical Information".

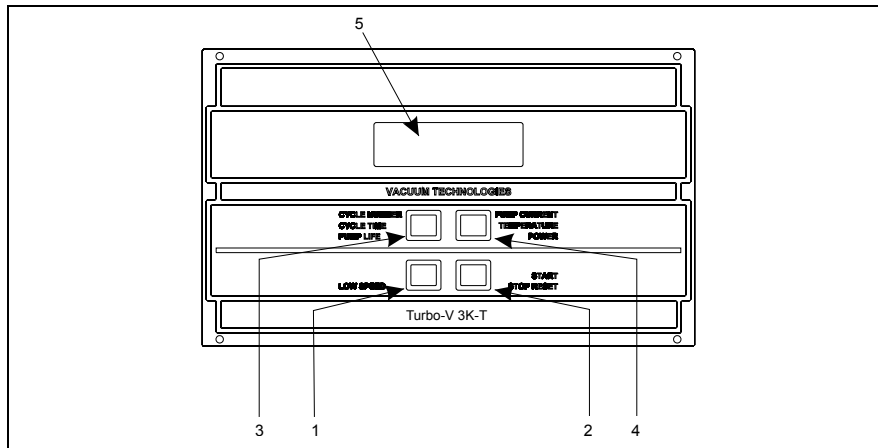

Figure 2 Controller 869-9447, 869-954 front panel

- | | |
|---|--|
| 1 | Keyboard push-button for HIGH/LOW SPEED mode selection. It is active only when the front panel operation has been selected. Pressed repeatedly, toggles between HIGH SPEED and LOW SPEED. |
| 2 | Keyboard push-button for START, STOP, RESET mode selection. It is active only when the front panel operation has been selected. By pressing once the starting phase begins; if pressed again it stops the pump. If the pump has been stopped automatically by a fault, this push-button must be pressed once to reset the controller and a second time to restart the pump. |
| 3 | Keyboard push-button to recall on the display the cycle number, cycle time and pumplife and serial number. |
| 4 | Keyboard push-button to recall on the display the pump current, pump temperature, pump power, rotational speed, flow value detected, type of gas and alarm status. It is always active regardless of the operating mode selected. Push-buttons 3 and 4, if pressed together for at least 2 seconds put the controller in a routine where it is possible to select some operation parameters. |
| 5 | LCD back-lighted alphanumeric display: dot matrix 2 lines x 16 characters. |

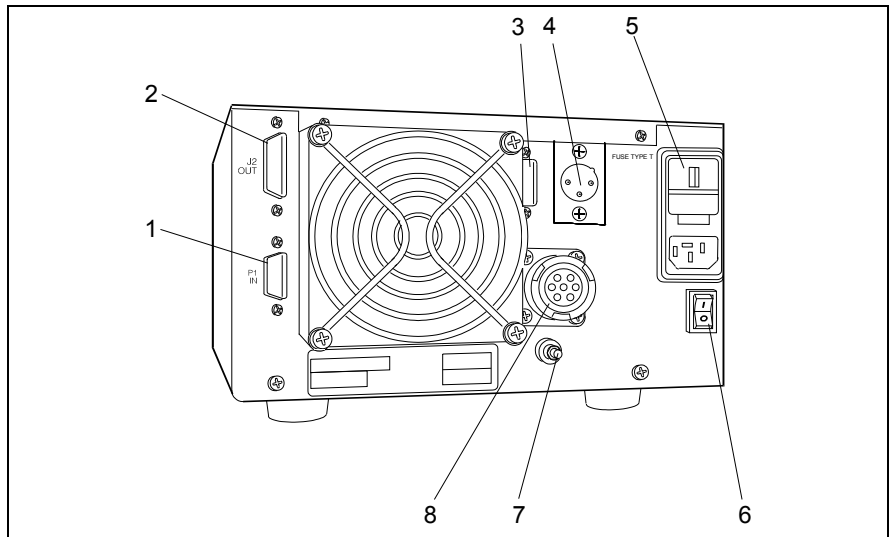

Figure 3 Controller 869-944 and 869-954 rear panel

1	Logic input signals connectors (mating connector supplied with link).
2	Logic signals, pump current monitor and activation frequency output connector.
3	Provision for RS-232 - RS-485 communication port connector (provided as an option). Purge vent connector.
4	Purge vent connector.
5	Controller power entry module consisting of mains fuses, voltage change over, mains socket and EMC filter.
6	Power switch.
7	Ground connection.
8	Pump cable socket.

Use procedure

Controller Startup

To startup the controller plug the power cable into a suitable power source and set the line switch to the position 1.

Starting the Pump

To start the pump press the START push-button on the controller front panel.

Pump Shutdown

To shutdown the pump press the STOP push-button on the controller front panel.

Maintenance

The Turbo-V 3K-T Rack Controller does not require any maintenance. Any work performed on the controller must be carried out by authorized personnel.

When a fault has occurred it is possible to use the Agilent repair service. Replacement controllers are available on an advance exchange basis through Agilent.

WARNING!

Before carrying out any work on the controller, disconnect it from the supply.



If a pump is to be scrapped, it must be disposed off in accordance with the specific national standards.

Disposal

Meaning of the "WEEE" logo found in labels

The following symbol is applied in accordance with the EC WEEE (Waste Electrical and Electronic Equipment) Directive. This symbol (**valid only in countries of the European Community**) indicates that the product it applies to must NOT be disposed of together with ordinary domestic or industrial waste but must be sent to a differentiated waste collection system. The end user is therefore invited to contact the supplier of the device, whether the Parent Company or a retailer, to initiate the collection and disposal process after checking the contractual terms and conditions of sale.

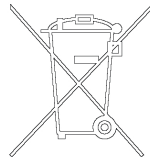

Error Messages

For a certain type of failure, the controller will self-diagnose the error and the messages described in the following table are displayed.

Tab. 1

MESSAGE	DESCRIPTION	REPAIR ACTION
CHECK CONNECTION TO PUMP	Wrong connection between the pump and the controller.	Check connection between controller and pump. Press the START push-button twice to start the pump.
PUMP WAITING INTERLOCK	The interlock signal of P1 connector is activated by an interruption of the link between pin 3 and 8 of J1 connector, or because the external interlock signal is open.	Reset the short circuit between pin 3 and pin 8 of J1 connector, or close the external interlock signal.
FAULT: PUMP OVERTEMP.	The pump upper bearing temperature exceeded 60 °C.	Wait until the temperature decrease below threshold value. Press the START push-button twice to start the pump.
FAULT: CONTROLLER OVERTEMPERATURE	The controller transformer temperature exceeded 90 °C.	Wait until the temperature decrease below threshold value. Press the START push-button twice to start the pump.
FAULT: TOO HIGH LOAD	In normal operation, the current drawn by the pump is higher than programmed.	Check that the pump rotor is free to rotate. Press the START push-button twice to start the pump.
FAULT: SHORT CIRCUIT	In normal operation (after the starting phase) the output connection is shorted.	Check connections and shortages between pump and controller. Press the START push-button twice to start the pump.

MESSAGE	DESCRIPTION	REPAIR ACTION
OVERVOLTAGE	A failure has occurred in the controller power supply section, or the controller has received a spurious signal.	Press the START button twice to start the pump again. If the message is redisplayed, contact Agilent for maintenance.
FLOW METER ALARM	Alarm relating to the purge flow. The flow value remained at less than the set threshold for 10 seconds or more.	Check the correct operation of the gas supply circuit.

16 Instructions for Use Error Messages



17

Technical Information

Turbo-V 3K-T Rack Controller Description	207
Controller Specifications	209
Controller Outline	209
Fuse Holder and Voltage Changer Assembly	211
Interconnections	212
Connection P1 - Logic Input Interconnections	212
Connection J2 - Logic Output Interconnections	214
Connection J7 Purge-Vent	216
Connection J10 - Controller to Pump Connection	218
Optional Serial Port	219
Serial Port Installation	220
Serial Communication Port J13	221
RS 232 Communication Descriptions	221
Transmission Channel Characteristics	221
RS 485 Communication Description	222
Transmission Channel Characteristics	221
Message Structure	222
Window-Based Protocol	222

Original Instructions



17 Technical Information

Error Messages

Use	232
General	232
Startup	233
Front / Remote Selection	237
Monitor Relay Programming	251
Starting the Pump	251
Operating the Pump	253
Pump Shutdown	253
Power Failure	254
Remote Control Mode Operation	254
RS 232/485 Control Mode Operation	255
Orderable Parts	255

Turbo-V 3K-T Rack Controller Description

The controller is available in two versions:

- Model 869-9447 (220 Vac, 50-60 Hz)
- Model 869-9547 (120 Vac, 50-60 Hz)

The models are provided with a front panel with an LCD alphanumeric display to indicate the operating conditions/parameters of the Turbo-V pump and a keyboard, and a rear panel with input/output connectors.

The following figure is a picture of the Turbo-V controllers. The controller is a solid-state frequency converter which is driven by a single chip microcomputer and is composed of:

- Power transformer
- Front panel display and keyboard
- Rear panel with input/output connectors
- PCB including: power supply analog and input/output section, microprocessor and digital section, display and keyboard circuits. The power supply converts the single phase (50-60 Hz) AC mains supply into a 3-phase, low voltage, medium frequency output which is required to power the Turbo-V pump.

The microcomputer generates the variable output frequency and controls the 3-phase output voltage according to the software and the gas load condition of the pump. Moreover, it manages signals from sensors, input/output connection information to be displayed, and gives outputs for a fully automatic operation. The heater jacket and flow meter are also handled. An EEPROM internal to the microprocessor is used to store pump operating parameters and the input/output programmed information.

The controller can be operated via:

- Front panel switches
- Remote signals via rear panel connectors
- RS 232/485/422 serial link (option)

17 Technical Information

Turbo-V 3K-T Rack Controller Description

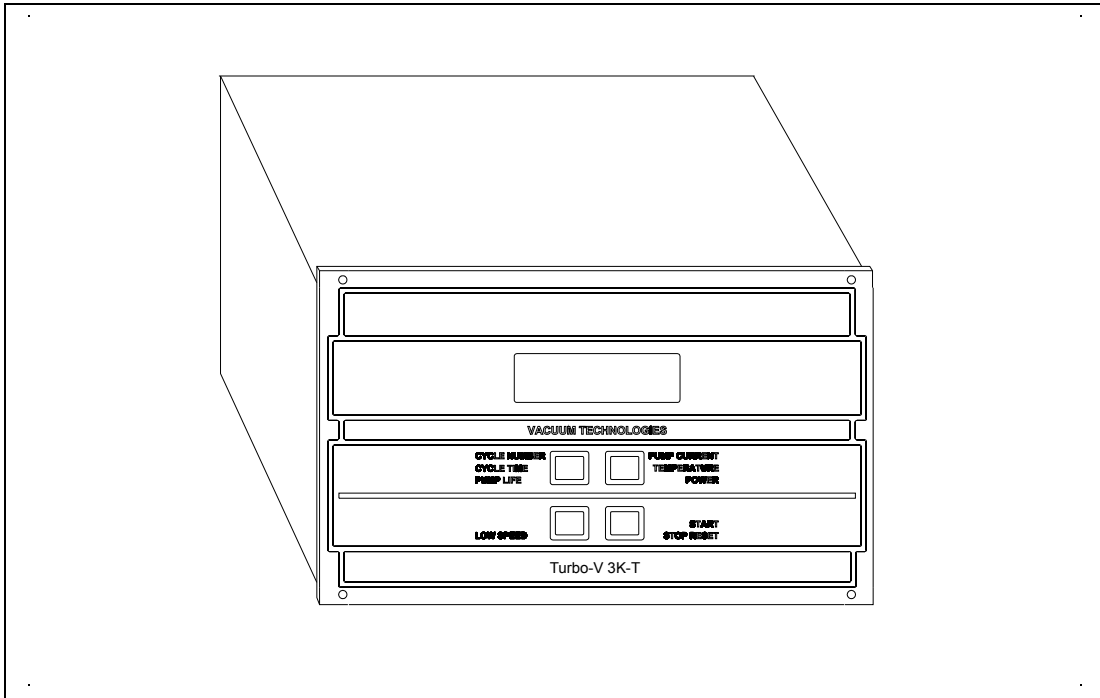

Figure 4 Turbo-V 3K-T Rack controllers

Controller Specifications

Tab. 2

Input:	
Voltage	100, 120, 220, 240 Vac, 1-phase
Frequency	50 to 60 Hz
Power	1300 VA maximum
Output for pump:	
Voltage	64 Vac
Frequency	530 Hz
Power starting	560 W maximum
Power normal	450 W maximum
Operating temperature	0 °C to +40 °C
Storage temperature	-20 °C to +70 °C
Fuse:	
Mains	2 x T5A(slow blow) for 220 or 240 input Voltage 2 x T10A(slow blow) for 100 or 120 input Voltage
P1 optoisolator input	Minimum ON 3mA, Maximum 5mA
J2 optoisolator output	24 Vdc, 60 mA
In compliance with norms	EN 61010-1 EN 61326-1 EN 55011 class A group 1 EN 6100-4-2 EN 6100-4-3 EN 6100-4-4 EN 6100-4-5 EN 6100-4-6 EN 6100-4-8 EN 6100-4-11 EN 6100-3-2
Max altitude	3000 m
Max line voltage variation	+/- 10%
Internal use only	
Weight (both models)	12,5 kg (28 lbs)
Installation category	II
Pollution degree	2

17 Technical Information

Controller Outline

NOTE All connecting cables for remote I/O and serial connections, if longer than 3 m, must be of the shielded type.

Controller Outline

The outline dimensions for the Turbo-V 3KT Rack Controller are shown in the following figures:

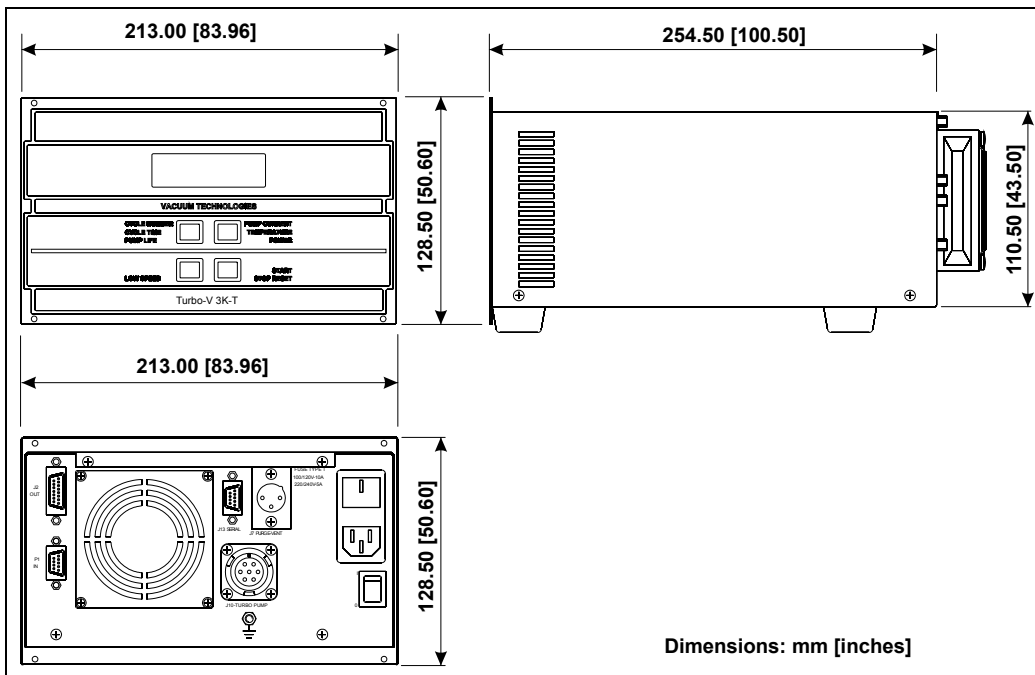

Figure 5 Controller models 869-9447 and 869-9547 outline

Fuse Holder and Voltage Changer Assembly

The following figure shows the location of this assembly.

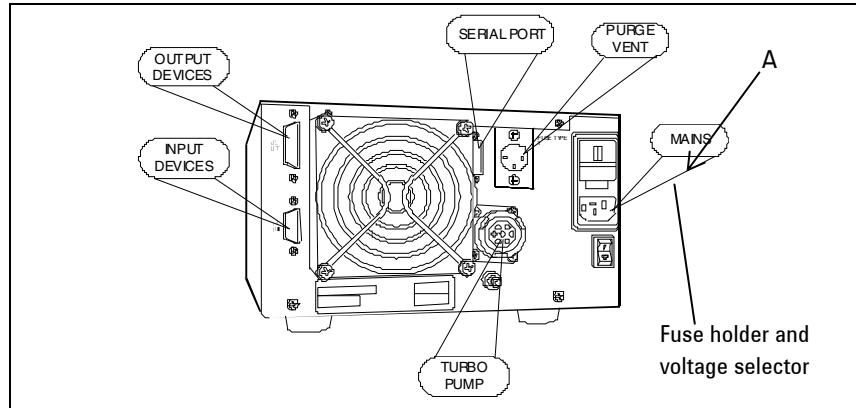

Figure 6 Rear panel

Proceed as follows to replace one or both fuses:

- 1 Remove the assembly by levering in position **A** with a small screwdriver.
- 2 Replace the fuse.

Use only T-type fuses of the following characteristics:

- 100/120 Vac 10 A
- 220/240 Vac 5 A

17 Technical Information

Interconnections

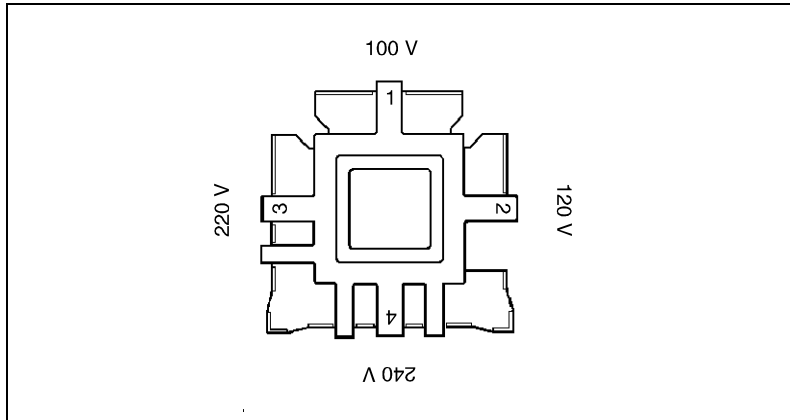

Figure 7 Voltage Changer

To change the power supply voltage rating after having removed the assembly as explained above, extract the voltage changer and then reposition it to view the desired voltage rating.

Interconnections

The following figure shows the Controller interconnections.

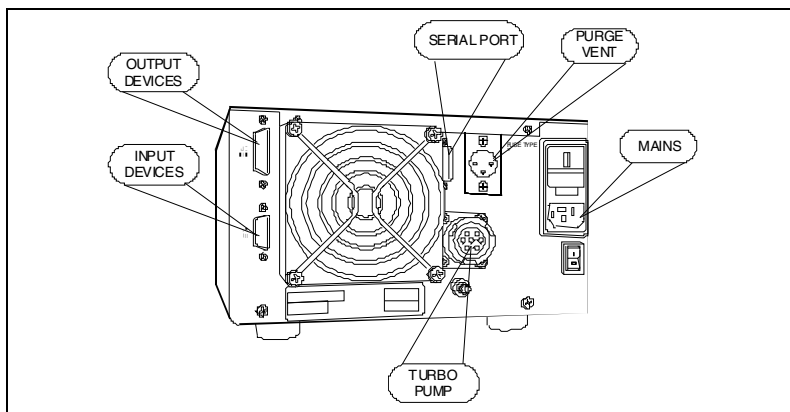

Figure 8 Controller models 869-9447 and 869-9547 interconnection

Connection P1 - Logic Input Interconnections

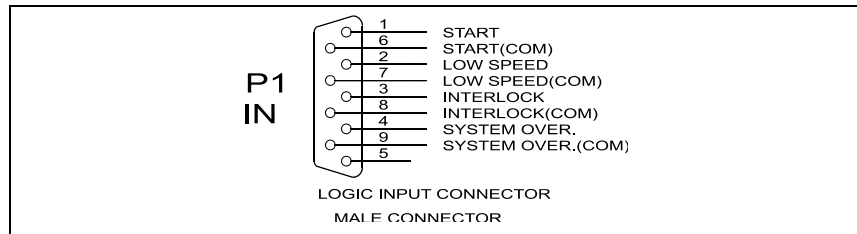

Figure 9 P1 input connector

All the logic input to the controller must be connected at J1 mating connector. With the provided J1 mating connector (shipped with pin 3 and pin 8 shorted) make the connections with AWG 24, (0.24 mm²) or smaller wire to the pins indicated in the figure to obtain the desired capability. The following table describes the signals available on the connector.

Tab. 3

PIN	DESCRIPTION
1-6	Remote START/STOP optically isolated from the internal circuit, requires a permanently closed contact (relay contact, transistor, etc.). When the contact closes the turbopump starts at high speed and when the contact opens, the turbopump is stopped. With the remote mode operation selected, the front panel push-button is inoperative.
2-7	Remote LOW SPEED optically isolated from the internal circuit, requires a permanently closed contact (relay contact, transistor, etc.). When the contact closes, the turbopump runs at low speed and when the contact opens, the turbopump reverts to high speed mode. With the remote mode operation selected, the front panel push-button is inoperative.
3-8	INTERLOCK optically isolated from the internal circuit, this signal can be used to delay the starting of the turbopump. It requires a permanent closed contact before starting the turbopump.
4-9	SYSTEM OVERRIDE optically isolated from the internal circuit, this signal is used to stop the pump in emergency condition, requires a closed contact. When the contact is closed, the turbopump and the interconnected devices are stopped until the operator: give the Start command (Local Mode); give the Stop command and Start command (Remote Mode).

17 Technical Information

Interconnections

NOTE

Pin 3-8 must be shorted to allow the Turbo-V 3 KT Rack Controller pump to start if no interlock contact is connected. If after starting the pump, the interlock contact opens, it has no effect on the operation and the pump continues to turn.

The following figure shows a typical contact logic input connection and the related simplified circuit of the controller.

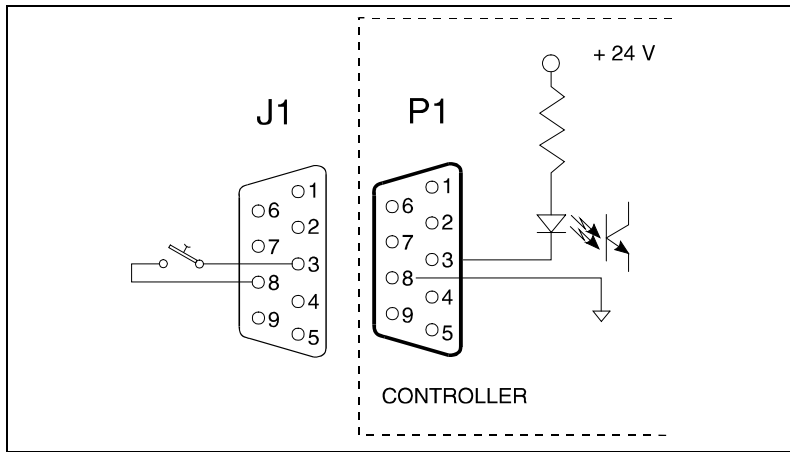

Figure 10 Typical logic input connection

Connection J2 - Logic Output Interconnections

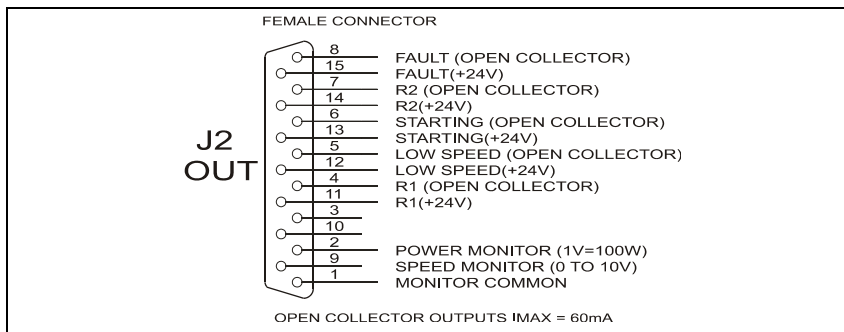

Figure 11 Logic output connector

All the logic output from the controller must be connected at P2 mating connector. With the optional P2 mating connector make the connection with AWG 24 (0.25 mm²) or smaller wire to the pins indicated in the figure to obtain the desired capability. The following table describes the signals available on the connector.

The following figure shows a typical logic output connection (relay coil) but any other device may be connected e.g. a LED, a computer, etc., and the related simplified circuit of the controller.

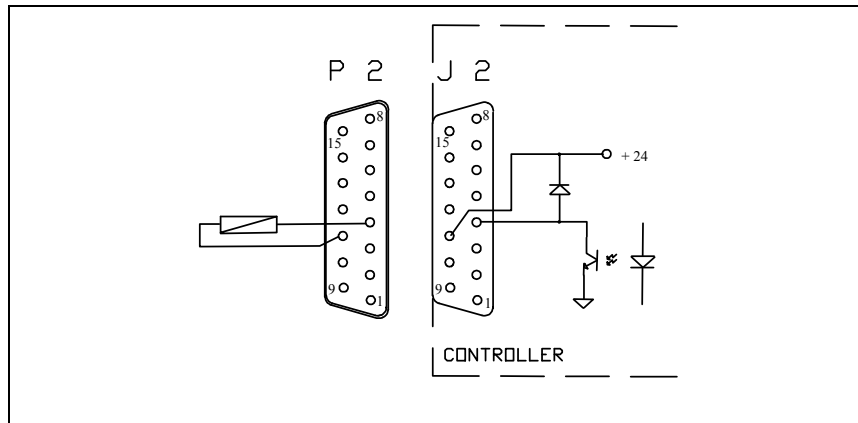

Figure 12 Typical output connection open collector

Tab. 4

PIN	DESCRIPTION
2-1	Analog output Voltage of power drawn by the turbopump (pin 2 positive, pin 1 negative). 1 Vdc proportional to 100 W.
4-11	R1 signal 24 V, 60 mA optically isolated output (pin 11 positive, pin 4 negative). The output Voltage will be present when the rotational speed of the pump is higher than the selected speed threshold
5-12	LOW SPEED signal, 24 V, 60 mA, optically isolated output (pin 12 positive, pin 5 negative). The output Voltage will be present when the low speed mode is selected, either through, the front panel, the remote signal, or RS 232/RS 485.
6-13	START signal 24 V, 60 mA, optically isolated output (pin 13 positive, pin 6 negative). The output Voltage will be present when the START push-button on front panel is pressed or the remote start is present, or the function has been requested by or RS 232/RS 485, until NORMAL operation is reached.

17 Technical Information

Interconnections

PIN	DESCRIPTION
7-14	<p>R2 signal 24 V, 60 mA, optically isolated output (pin 14 positive, pin 7 negative). The output Voltage will be present upon the programmed condition delay YES or delay NO (see the cycle diagram in the following pages).</p> <p>If YES is selected, R2 is off and the output is zero over all run up time, than:</p> <p>If running speed > speed threshold R2 = OFF</p> <p>If running speed < speed threshold R2 = OFF</p> <p>If NO is selected:</p> <p>If running speed > speed threshold R2 = OFF</p> <p>If running speed < speed threshold R2 = ON</p>
8-15	<p>FAULT signal 24 V, 60 mA, optically isolated output (pin 15 positive, pin 8 negative). The output Voltage will be present when a fault condition is displayed on the front panel display.</p>
9-1	<p>Analog output voltage (0 – 10 V) proportional to pump speed (pin 9 positive, pin 1 negative).</p>

Connection J7 Purge-Vent

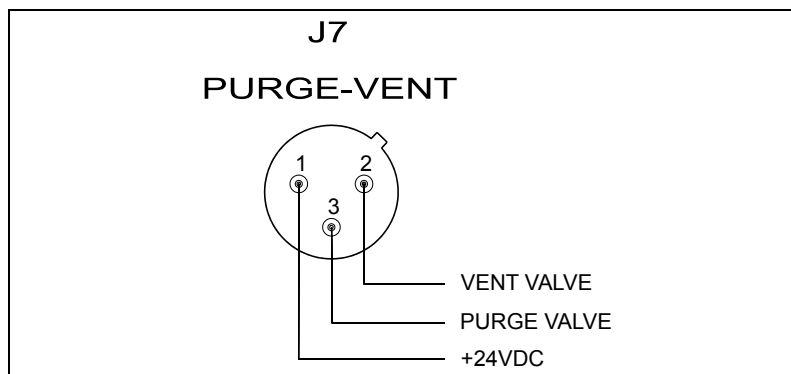
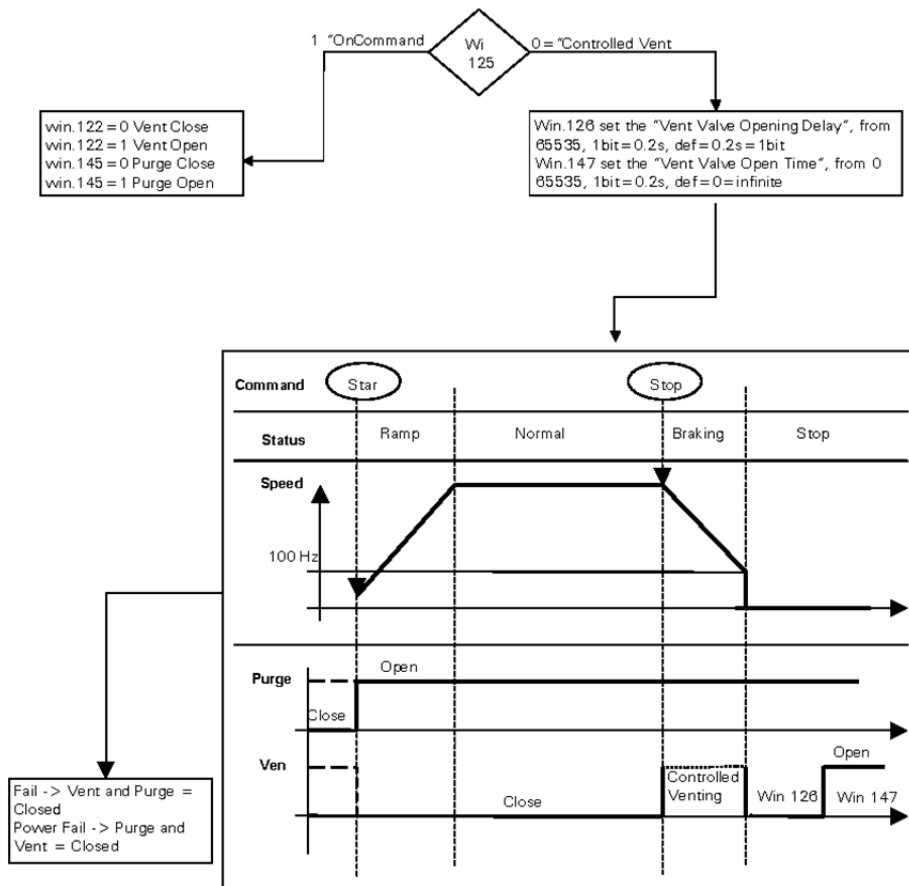

Figure 13 J7 connectors

The integrated purge-vent valves (if present on the pump) can be driven by the controller, in this case use the “purge-vent valves cable” reported in the “ordrable parts” table.

The Turbo-V 3K-T pump can integrate the purge and vent valves. The two valves are Normally Closed so if a power fail occur, the valves will remain closed. The valves operating mode is independent from the controller operating mode. The valve operating mode can be set by serial line by win.125 or by front panel using the “program menu”, see following diagram for details. Note that the vent and purge valve can also be controlled by means of the serial connection (see the following diagram for details).



Controlled Vent Procedure

The default setting for vent operating mode is “Controlled Vent Procedure” (Win 125 = 0).

When activated the procedure guarantees that the pump is slowed down properly modulating in automated way the vent valve.

If WIN 125= 1 the vent valve is opened via serial or Remote I/O, but the “Controlled Vent Procedure” is automatically activated until the speed of pump is 100 Hz.

NOTE

The vent could damage the pump. Please, use the Agilent “Controlled Vent Procedure” or refer to Agilent personnel.

Connection J10 - Controller to Pump Connection

A five-meter long cable is provided to connect the controller to the pump. The following figures show the controller output connector configuration where pins:

- A-F = upper bearing sensor
- B-C-D = 64 Vac 3-phase output to pump motor stator
- E = ground
- A-G =lower bearing sensor

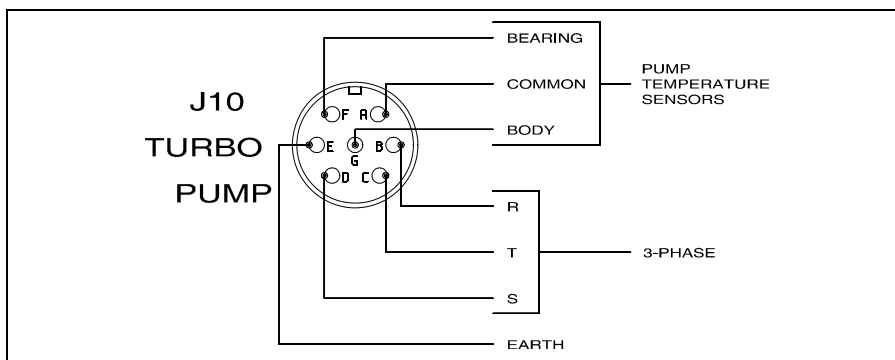

Figure 14 Controller-to-pump connector (applicable to model 869-9447 and 869-9547)

Optional Serial Port

NOTE

The Controller can be read when set in the Front/Remote mode, (read window only enabled), while it can be written to and read when set in the Serial mode (write window enabled).

Serial Port Installation

An optional RS 485 kit is available for both models. To install it, proceed as follows:

- 1 Switch off the power and disconnect the power cord.
- 2 Unscrew the cover screws and remove the cover.
- 3 On rear panel, remove the connector plate, and then secure connectors J13 to the frame using the turrets provided.
- 4 On rear panel, remove the fixing turrets of connectors **B** and **C** and then remove the controller.
- 5 Attach the interface board connector to connector P6 on the controller and then secure it in place using screw **A** (3x6), which is not provided.
- 6 Insert the flat cable through the rear panel and plug it into the socket **P1** located on the Interface board.
- 7 Restore the main board into its original position.
- 8 Install and tighten the connector screws and turrets.
- 9 Replace the cover.

17 Technical Information

Optional Serial Port

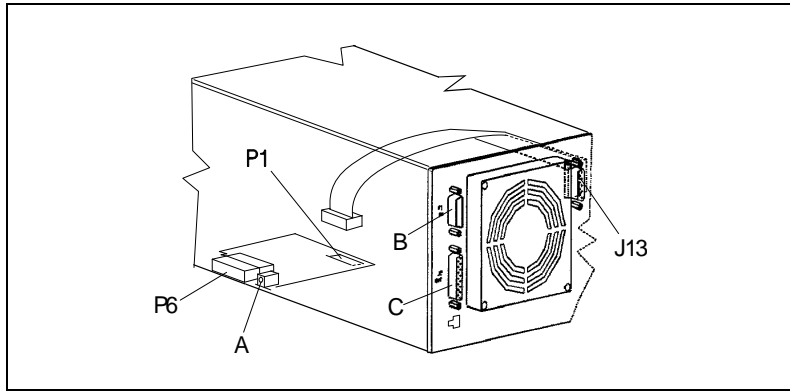

Figure 15 Serial port connector installation

Serial Communication Port J13

Communication serial port connections and minimum connection configuration are shown in the following figures. The communication port mating connector is supplied with the RS 232 PCB (AMP/Cannon or equivalent 9-pin "D" type male connector). The external cable (not supplied) between the host computer and the controller does not require crossed wires so that signals are connected correctly. For example, the Transmit data signal from controller (pin 2) must be connected to the host computer's Receive data line (pin 2) and vice versa. Consult the host computer's instruction manual for its serial port connections.

NOTE

Agilent cannot guarantee compliance with FCC regulations for radiated emissions unless all external wiring is shielded, with the shield being terminated to the metal shroud on the O-subconnector. The cable should be secured to the connector with screws.

RS 232 Communication Descriptions

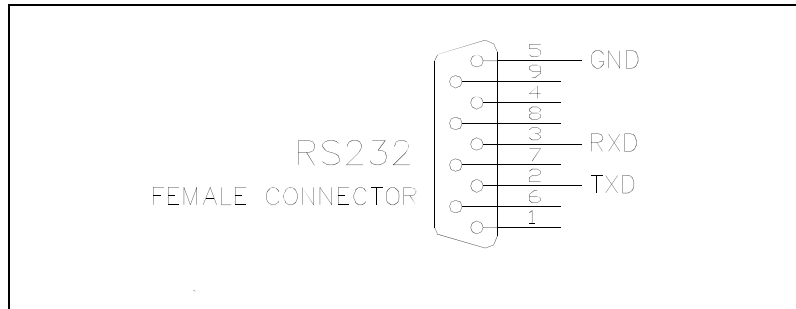

Figure 16 Communication RS 232 serial port connections

Transmission Channel Characteristics

levels:	RS 232
baud rate:	9600/4800/2400/1200/600 programmable
character length:	8 bits
parity:	none
stop bit:	1 bit
protocoll:	master (PC) / slave (converter)

In this case the value to be assigned to the ADDRESS field must be 80 hex (for RS 232).

RS 485 Communication Description

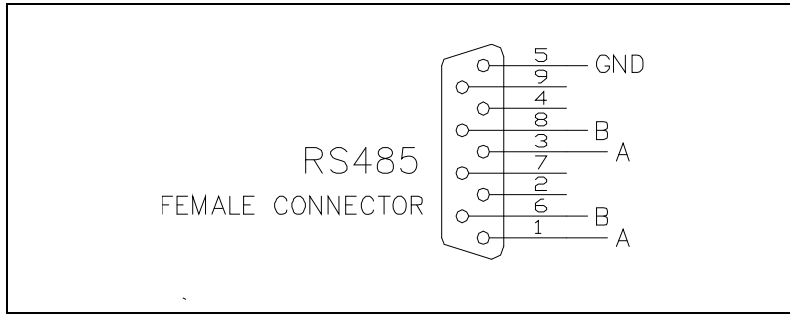

Figure 17 Communication RS 485 serial port connections

Transmission Channel Characteristics

levels:	RS 485
baud rate:	9600/4800/2400/1200/600 programmable
character length:	8 bits
parity:	none
stop bit:	1 bit
protocoll:	master (PC) / slave (converter)
max. devices:	32

Message Structure

(request and answer have the same format)

The master system (PC) starts every session sending the following message to the slave units connected:

<STX> / <ADDR> + <WINDOW> + <COMMAND> + <DATA> + <ETX>
+ <CRC>

where:

<STX> = 0x02

<ADDR> = 0x80 (for RS 232)

<ADDR> = 0x80 + device number (0...31)
0xFF: broadcasting command (recognized by all the devices, it doesn't implicate any answer)
(for RS 485 only)

<WINDOWS> = ' 000 '...' 999' window number the meaning of the window depends to the device type

<COMMAND> = 0x30: window value reading
0x31: window writing

<DATA> = alphanumeric ASCII string containing, in the case of writing operation, the parameter to input into the window addressed by the field <WINDOW> This field may have variable length according to the data type contained in the window where you are working in. In the case of reading request of a window, the data field doesn't exist.

<ETX> = 0x03

<CRC> = XOR among all the characters following <STX> = (with exception of <STX>), including the end character <ETX> hexadecimally encoded by two ASCII characters.

17 Technical Information

Optional Serial Port

- 1 When a slave device is addressed by the master:
In case of reading request of the value contained in a window, the slave answers a string equal to the one sent by the master but in addition there is the field <DATA> containing the value of the window. The format of the field <DATA> depends to the window type.
 - The different types are:

Tab. 5

	Length	Characters Permitted
Logic (L)	1	'0'=OFF '1'=ON
Numeric (N)	6	'0'...'9' (Justified to the right with '0')
Alphanumeric (A)	max 10	' '...'_'

Examples

Command: START

Source: PC

Destination: Inverter

02	80	30	30	30	31	31	03	42	33
STX	ADDR	WINDOW			WR	ON	ETX	CRC	

Source: Inverter

Destination: PC

02	80	06	03	38	35
STX	ADDR	ACK	ETX	CRC	

Command: STOP

Source: PC

Destination: Inverter

02	80	30	30	30	31	30	03	42	32
STX	ADDR	WINDOW			WR	OFF	ETX	CRC	

Source: Inverter

Destination: PC

02	80	06	03	38	35
STX	ADDR	ACK	ETX	CRC	

17 Technical Information

Examples

Command: SOFT-START (ON)

Source: PC

Destination: Inverter

02	80	31	30	30	31	31	03	42	32
STX	ADDR	WINDOW			WR	ON	ETX	CRC	

Source: Inverter

Destination: PC

02	80	06	03	38	35
STX	ADDR	ACK	ETX	CRC	

Command: SOFT-START (OFF)

Source: PC

Destination: Inverter

02	80	31	30	30	31	30	03	42	33
STX	ADDR	WINDOW			WR	OFF	ETX	CRC	

Source: Inverter

Destination: PC

02	80	06	03	38	35
STX	ADDR	ACK	ETX	CRC	

Command: LOW SPEED (ON)

Source: PC

Destination: Inverter

02	80	30	30	31	31	31	03	42	32
STX	ADDR	WINDOW			WR	ON	ETX		CRC

Source: Inverter

Destination: PC

02	80	06	03	38	35
STX	ADDR	ACK	ETX	CRC	

Command: LOW SPEED (OFF)

Source: PC

Destination: Inverter

02	80	30	30	31	31	30	03	42	33
STX	ADDR	WINDOW			WR	OFF	ETX		CRC

Source: Inverter

Destination: PC

02	80	06	03	38	35
STX	ADDR	ACK	ETX	CRC	

17 Technical Information

Examples

Command: CURRENT

Source: PC

Destination: Inverter

02	80	32	30	30	30	03	38	31
STX	ADDR	WINDOW		RD	ETX	CRC		

Source: Inverter

Destination: PC

02	80	32	30	30	30	30	30	30	2E	30	30	03	39	46
STX	ADD	WINDOW		RD	000.00						ETX	CRC		

Command: FREQUENCY

Source: PC

Destination: Inverter

02	80	32	30	33	30	03	38	32
STX	ADDR	WINDOW		RD	ETX	CRC		

Source: Inverter

Destination: PC

02	80	32	30	33	30	30	30	30	30	33	38	03	38	39
STX	ADD	WINDOW		RD	000038						ETX	CRC		

Command: ERR-CODE

Source: PC

Destination: Inverter

02	80	32	30	36	30	03	38	37
STX	ADDR	WINDOW			RD	ETX	CRC	

Source: Inverter

Destination: PC

02	80	32	30	36	30	30	30	30	30	30	30	03	38	37
STX	ADD	WINDOW			RD	000000						ETX	CRC	

NOTE

Using the RS 485 interface, the message structure remains identical to the one used for the RS 232 interface, the only difference being that the value assigned to the ADDRESS <ADDR> field in this case can be any hex value, while for the RS 232 this value must be set to 80 hex.

Window-Based Protocol

The following table, valid for the RS 232, and RS 485 interfaces, describes each single window used in the protocol.

Tab. 6

WIN	Type	Description
000	L	START/STOP
001	L	LOW SPEED [0 = OFF / 1 = ON]
100	L	SOFT START YES/NO (1= YES ; 0= NO)
101	L	DELAY EVEN AFTER THRESHOLD [0 = OFF / 1 = ON]
102	L	WATER COOLING [0 = OFF / 1 = ON]
103	N	SPEED THRESHOLD (from 0 to 999 Hz)
104	N	RUN UP TIME (0 ÷ 359.999 sec)
107	N	MODE (0, 1, 2) [FRONT, REMOTE, SERIAL]
108	N	BAUD_RATE (0-4) [600, 1200, 2400, 4800, 9600]
109	L	PUMP LIFE RESET [write "1" to reset]
116	N	HIGH SPEED ADJUST [Hz]
117	N	LOW SPEED ADJUST [Hz]
118	L	BODY TEMP ENABLE (0=NO, 1=YES)
119	L	HOST PRINTER MODE [0=HOST / 1=PRINTER]
122	L	SET VENT VALVE (1=ON ; 0=OFF)
125	L	SET THE VENT VALVE OPERATION [0=controlled vent 1=on command]
126	N	VENT VALAVE OPENING DELAY (expressed in sec, max 65535 sec)
145	L	PURGE OPERATION (0= CLOSE, 1 = OPEN)
147	N	VENT OPEN TIME (1 sec/bit, 0=always open, max 65535 sec)
167	L	STOP SPEED READING
200	N	CURRENT [A]
201	N	VOLTAGE [V]
202	N	POWER [W]
203	N	DRIVING FREQUENCY [Hz]
205	N	STATUS [0=stop; 1= waiting interlock; 2=starting; 3=normal; 4=high load; 5=failure; 6=approaching]

WIN	Type	Description
206	N	ERROR CODE [0=no error, 1=overvolt, 2=short circuit, 3=check conn., 4=too high load, 5=override, 6=overtemp pump, 7=overtemp controller]
207	L	STATE R1 [0 = OFF / 1 = ON]
208	L	STATE R2 [0 = OFF / 1 = ON]
209	N	UPPER BEARING TEMPERATURE (°C)
210	N	PUMP BODY TEMPERATURE (°C)
300	N	CYCLE TIME [min]
301	N	CYCLE NUMBER
302	N	PUMP LIFE [h]
319	A	CONTROLLER MODEL
320	A	PUMP MODEL NUMBER
323	A	CONTROLLER SERIAL NUMBER
400	A	PROGRAM LISTING CRC [QEYxxxx]
402	A	PARAMETER LISTING CRC [PAYxxxx]
406	A	PROGRAM LISTING CODE & REVISION
407	A	PARAMETER LISTING CODE & REVISION
501	L	ENTER USER MODE
502	N	ENTER TEST MODE (exit with password)

WIN = Window

T = Type

L = Logical

N = Numeric

A = Alphanumeric

Use

General

Make all vacuum manifold and electrical connections and refer to Turbo-V 3K-T pump instruction manual before to operating the Turbo-V 3K-T controller.

WARNING!



To avoid injury to personnel and damage to the equipment, if the pump is laying on a table make sure it is steady. Never operate the Turbo-V ICE pump if the pump inlet is not connected to the system or blanked off.

NOTE

The input signal P1 connector should be left in position including the shipping links if no external connections are made. The forepump and the Turbo-V 3K-T pump can be switched on at the same time.

NOTE

When the Turbo-V 3K-T Rack Controller pump is baked by a membrane pump, the Soft Start mode should be deselected.

Startup

- Plug the controller power cable into a suitable power source.
- The display lights, and shows:

				A	U	T	O	T	E	S	T			
					C	H	E	C	K					

NOTE

The above message is only displayed when a board with optional serial ports is installed.

				A	U	T	O	T	E	S	T			
							O	K						

The controller with the Soft Start mode allows the pump to ramp-up to Normal Speed slowly with a minimum ramp-up time of 30 minutes and a maximum of about 55 minutes.

The Soft Start mode is always operative as default mode. If it is necessary to deselect this mode refer to the following paragraph. If the Soft Start mode is deselected, the ramp- up will be done within 360 seconds and the display changes as follows:

P	U	M	P		R	E	A	D	Y	:		P	U	S	H
	S	T	A	R	T		B	U	T	T	O	N		H	S

17 Technical Information

Use

NOTE

If the pump is not connected, the display will be as shown:

C	H	E	C	K		C	O	N	N	E	C	T	I	O	N
			T	O		P	U	M	P					H	S

NOTE

After pressing the START push-button, if the P1 connector is not in place with the link or the external interlock connection are open, the display will be as shown in the following figure.

P	U	M	P		W	A	I	T	I	N	G				
I	N	T	E	R	L	O	C	K							

Unplug the controller power cable and verify the P1 connection according to paragraph “Interconnections”.

- Press the PUMP CURRENT push-button and the display shows (e.g.):

With reference to two temperature sensors T1 and Tb.

X	X		K	R	P	M			P	=	X	X	X	W	
T	1	=	X.	X.	°	C			T	2	=	X	X.	°	C

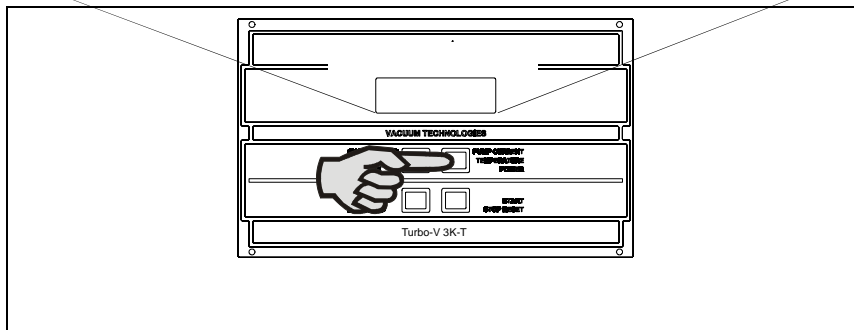

Figure 18

- Press the PUMP CURRENT push-button and the display shows:

X	X	X		H	Z				P	=	X	X	X	W	
			V	=	X	X	V		I	=	X	X	.	X	A

Where:

- I** = is the DC current drawn by the pump range (0.00 to 10.0 Ampere)
- P=** is the DC power drawn by the pump (range 0 to 999 Watt)
- Hz** = is the theoretical rotational speed of the pump as a function of the controller output frequency (range 50 to 530 KRPM)
- T1** = is the temperature of the outer ring of the upper bearing (range 00 to 99 °C)
- Tb** = is the temperature of the outer ring of the lower bearing (range 00 to 99 °C)
- V** = is the pump voltage
- Press the PUMP CURRENT push-button and the display shows

X	X	X		H	z				P	=	X	X	X	W	
			N	2		P	L	I	M	=	X	X	X	W	

Where:

- N2** = Gas flow (Nitrogen or Argon) expressed in SCCM (Standard cubic centimeters per minute)

17 Technical Information

Use

- Press the **CYCLE NUMBER** push-button twice and the display shows:

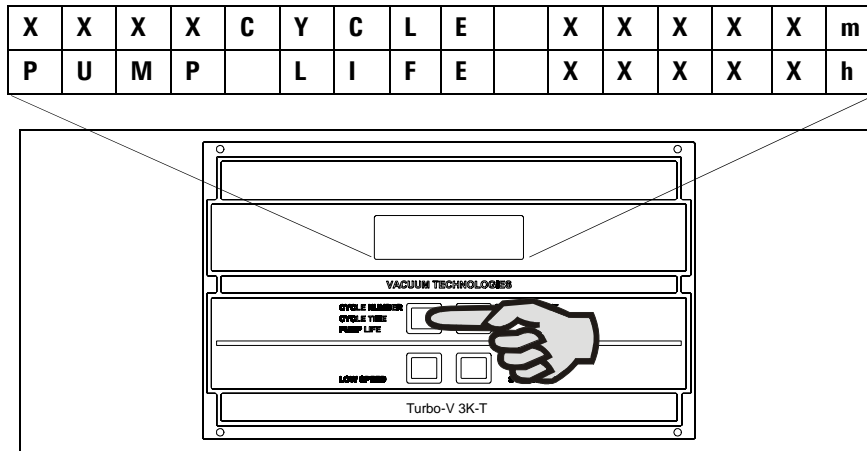

Figure 19

Where:

- **CYCLE** = are the cycles performed (range 0 to 9999)
- **m** = is the elapsed time related to the cycle number displayed (range 0 to 99999 minutes)
- **PUMP LIFE** = is the total operation time of the pump (range 0 to 99999 hours).

Front / Remote Selection

Press CYCLE NUMBER and PUMP CURRENT pushbuttons together for at least 2 seconds and the processor enters a routine where it is possible to program the controller. In this routine, the CYCLE push-button is used for choosing/changing the value or condition; the PUMP CURRENT push-button is used to enter and confirm the value. At any time it is possible to exit this routine by pressing the CYCLE and PUMP CURRENT pushbuttons at the same time for at least 2 seconds.

The display shows:

C	O	N	F	I	G	U	R	A	T	I	O	N			

H	I	G	H		S	P	E	E	D						
S	E	T	T	I	N	G	:		X	X	X		H	z	

Where:

- **XXX** = 510 ÷ 530 Hz

Confirm the flashing digit by pressing the PUMP CURRENT key.

L	O	W			S	P	E	E	D						
S	E	T	T	I	N	G	:		X	X	X		H	z	

Where:

- **XXX** = 510 ÷ 530 Hz

Confirm the flashing digit by pressing the PUMP CURRENT key.

S	O	F	T		S	T	A	R	T		M	O	D	E	
S	E	L	E	C	T	I	O	N	:		X	X	X		

17 Technical Information

Use

Where:

- **XXX** = YES or NO

If YES is selected, the Soft Start mode allows the pump to rump-up the Normal speed within ten steps. When NO is selected, the Soft Start mode is deselected and the rump-up of the pump will be done within 360 seconds.

The controller is factory set to YES.

NOTE

The Soft Start mode may be deselected/selected only when the pump is stopped.

- Press CYCLE NUMBER push-button to select YES or NO

S	O	F	T		S	T	A	R	T		M	O	D	E	
S	E	L	E	C	T	I	O	N	:		Y	E	S		

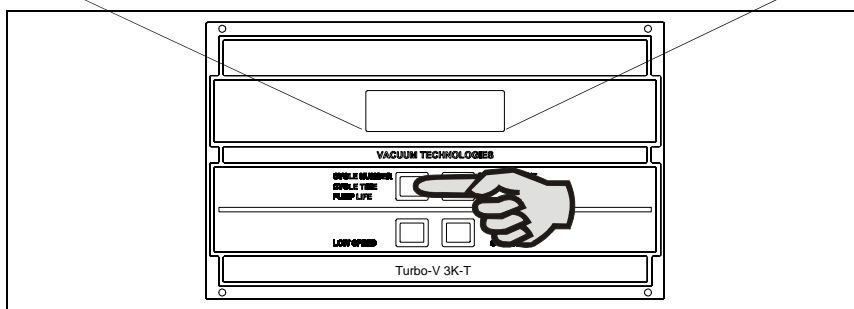

Figure 20

- Press the PUMP CURRENT push-button and the display shows:

P	R	O	C	E	S	S		G	A	S	?				
					A	R	G	O	N						

Select the type of purge gas, the default is air. Argon can be selected if needed.

- Enter the selection by pressing the PUMP CURRENT push-button, and the display shows:

F	R	O	N	T	/	R	E	M	O	T	E	/	S	E	R
S	E	L	E	C	T	I	O	N	:	X	X	X	X	X	X

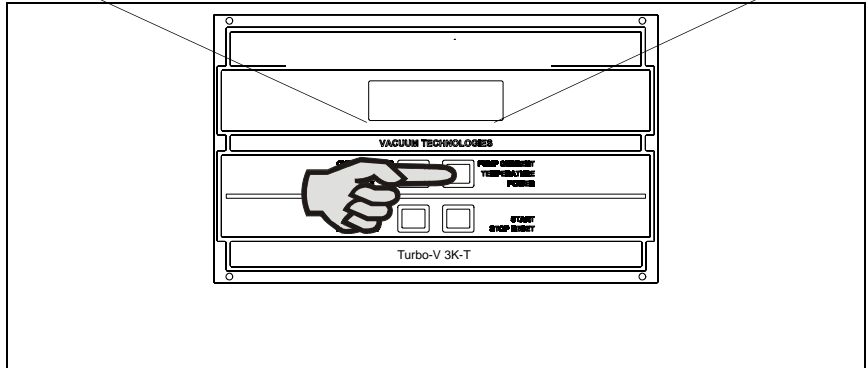

Figure 21

where: **XXXXXX** = means the word FRONT, REMOTE, or SER depending on the last selection. The controller is factory-set for FRONT panel operation. SER will only be displayed if the optional serial card is installed.

- Choose the desired selection by pressing the CYCLE push-button.

F	R	O	N	T	/	R	E	M	O	T	E	/	S	E	R
S	E	L	E	C	T	I	O	N	:	F	R	O	N	T	

17 Technical Information

Use

- Press the PUMP CURRENT push-button to enter the value and if the serial option is installed, the display shows:

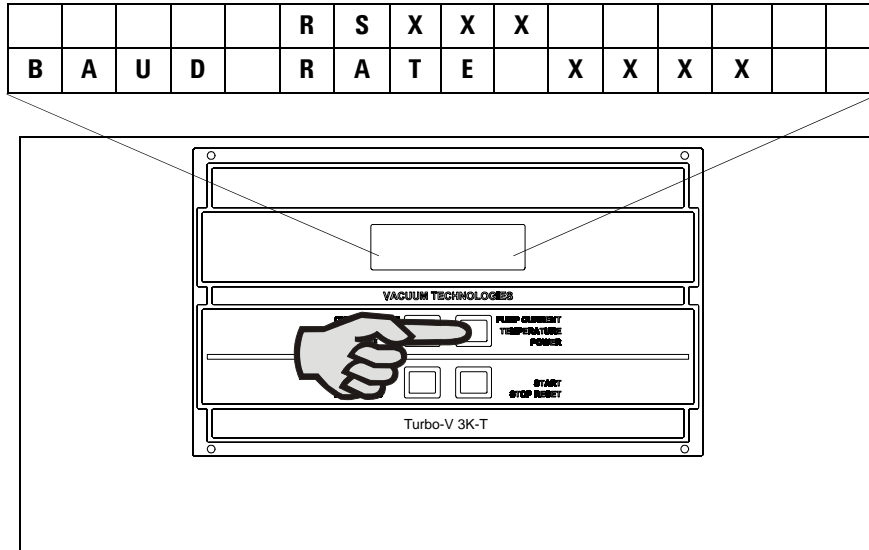

Figure 22

Where:

BAUD RATE **XXXX** = means 600, 1200, 2400, 4800, 9600 baud rate for the host computer or printer communication. The controller is factory-set for 9600 baud rate operation.

The value which corresponds to the board installed will be assigned to RSXXXX.

- Press PUMP CURRENT push-button and the display shows:

	S	E	R	I	A	L		A	D	D	R	E	S	S	
							X	X							

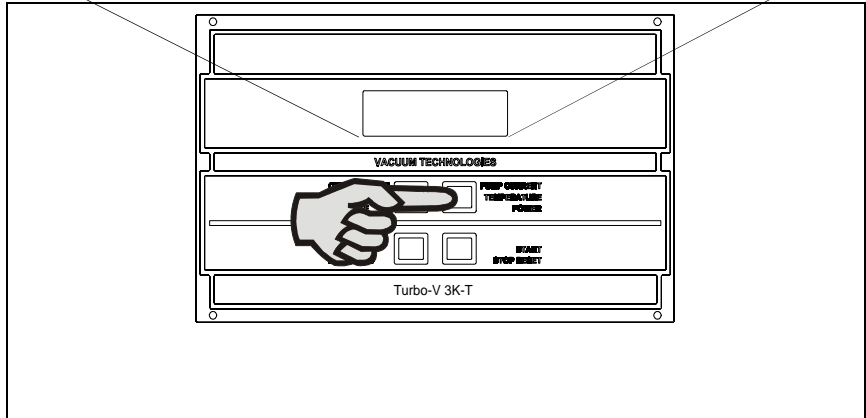

Figure 23

This message will only be displayed if the RS 485 module is installed.

Where: **XX** = 00 ÷ 31 is the unit address

17 Technical Information

Use

- If the RS 232 is installed, enter the value by pressing the PUMP CURRENT push-button and, if the serial option is installed, the display shows:

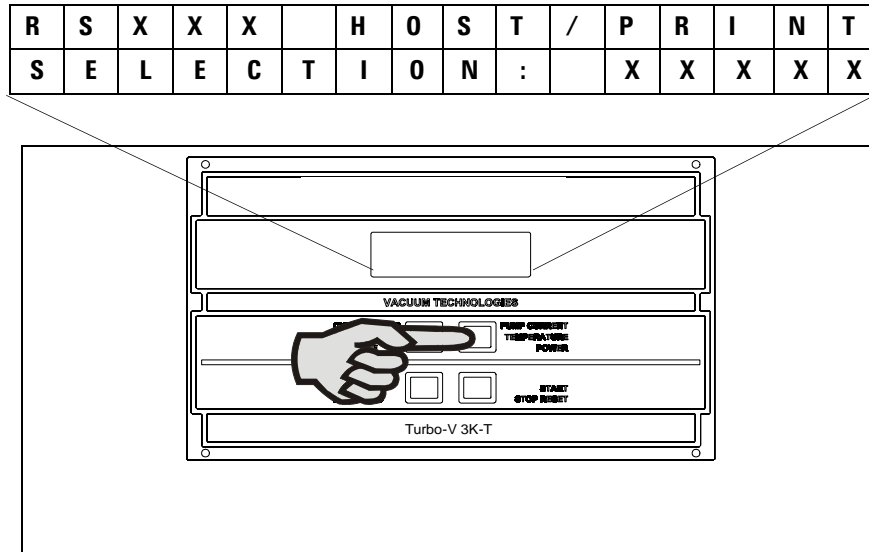

Figure 24

This message will only be displayed if the RS232 interface is present.

Where: SELECTION: **XXXXXX** = means HOST or PRINT.

The controller is factory-set to HOST

With the RS 232/485 connected, a bi-directional communication is established by selecting HOST. Data are sent to an external computer every time the external computer asks for the values.

The available data are listed in the read mode in the serial protocol table.

NOTE

With the serial module installed, the data can also be read in the FRONT or REMOTE mode.

If PRINT is selected and a printer is connected on RS 232 line, an unidirectional communication is established and every minute the data are sent to the printer, even if the pump is not running.

The set of data available are:

- Pump speed Hz
- Pump temperature
- Pump current A
- Pump power W
- R1 condition
- R2 condition
- Confirm the selection by pressing the PUMP CURRENT push-button.
- In this way you enter into an operating phase named "Monitor Relay Programming" described later.
- Enter the value by pressing the PUMP CURRENT push-button.

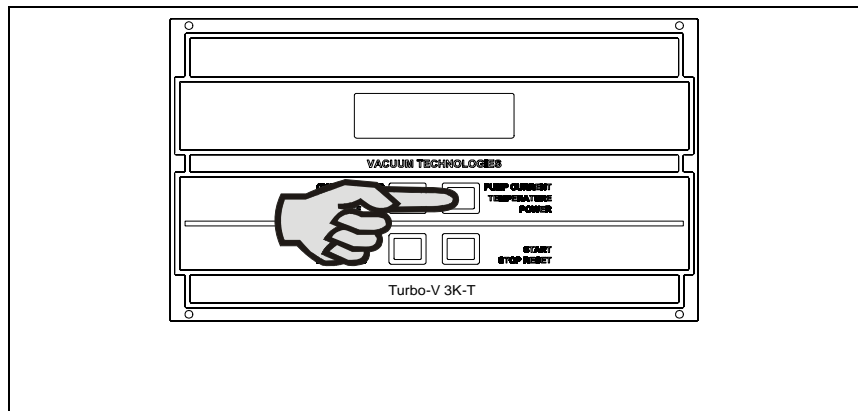

Figure 25

Monitor Relay Programming

The display shows:

S	P	E	E	D		T	H	R	E	S	H	O	L	D	
S	E	L	E	C	T	I	O	N	:	X	X	X		H	z

where: **XXX HZ** = is the switch point of relay R1 at the preset turbopump speed, adjustable from 100 to 500 HZ.

The speed threshold will condition the R1 and R2 operation (see the following cycle diagram) and it is factory-set to 36 Hz. Press the CYCLE NUMBER push-button to select the first number.

S	P	E	E	D		T	H	R	E	S	H	O	L	D	
S	E	L	E	C	T	I	O	N	:	X	X	X		H	z

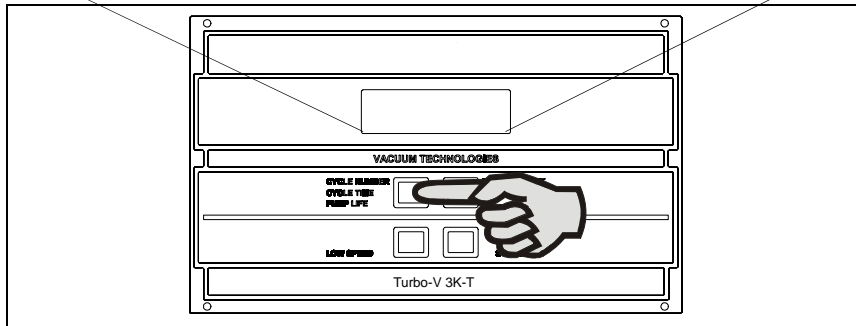

Figure 26

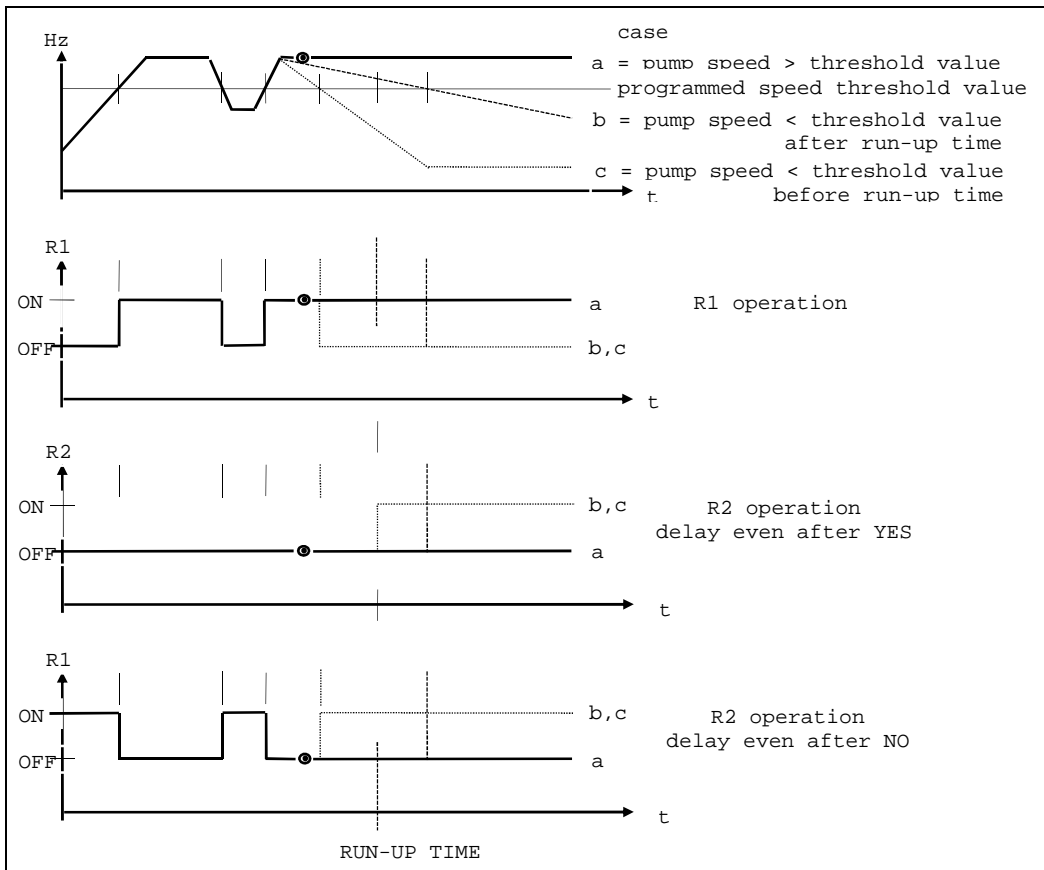

Figure 27 Cycle diagram

17 Technical Information

Use

- Enter the value by pressing the PUMP CURRENT push-button.

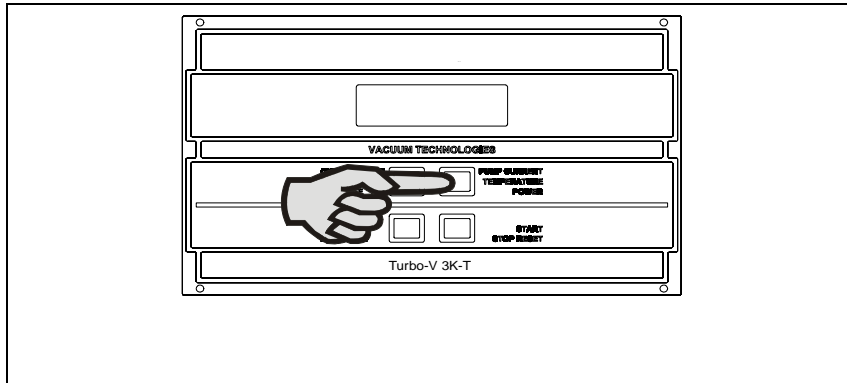

Figure 28

- Press the CYCLE NUMBER push-button to select the second number.

S	P	E	E	D		T	H	R	E	S	H	O	L	D	
S	E	L	E	C	T	I	O	N	:	X	X	X		H	z

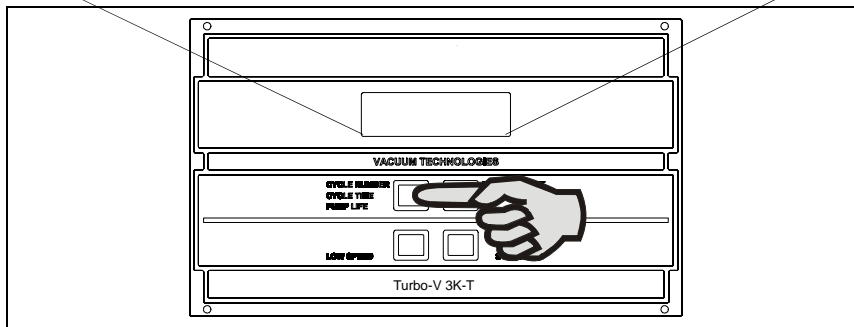

Figure 29

- Enter the value by pressing the PUMP CURRENT push-button, and the display shows:

R	U	N	-	U	P		T	I	M	E					
S	E	L	:		X	X	h		X	X	m		X	X	s

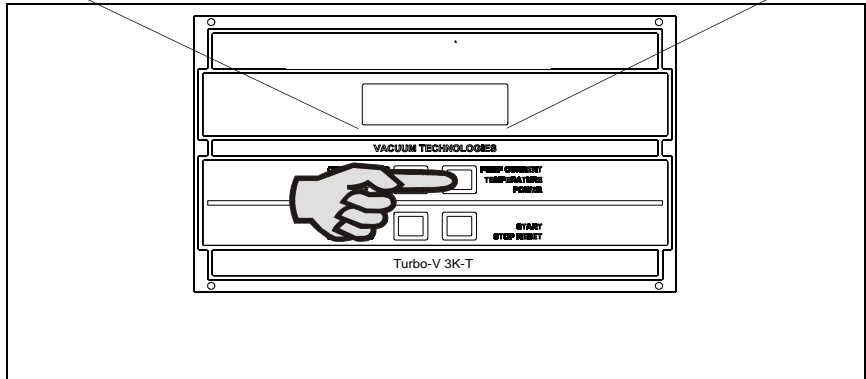

Figure 30

where: **RUN-UP TIME** = is the interval time from start to speed threshold value in hours, minutes, seconds. Select from 00 to 99 hours, and from 00 to 59 minutes or seconds.

Select the run-up time according to the chamber volume and/or operating cycle feature (see the preceding cycle diagram) by pressing the CYCLE NUMBER push-button to select the desired number.

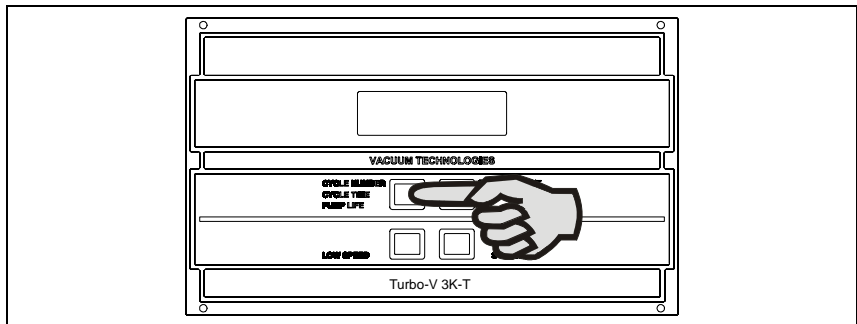

Figure 31

17 Technical Information

Use

- Press the PUMP CURRENT push-button to enter the data.

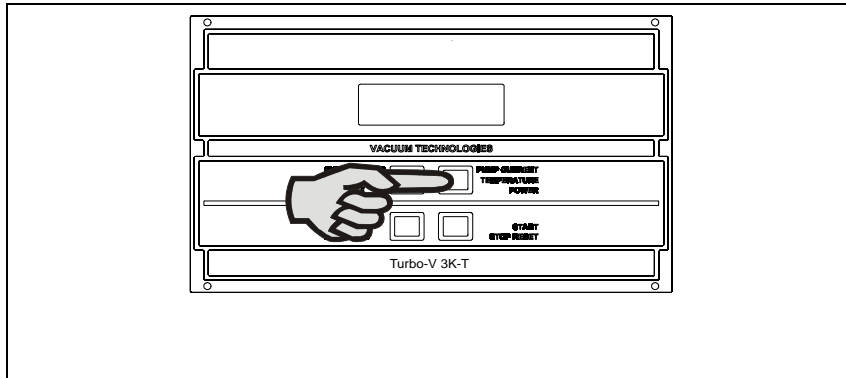

Figure 32

The run up time is factory-set to: 00h 08m 00s.

- Press the PUMP CURRENT push-button to enter the data.

When the last digit is entered, the display shows:

D	E	L	A	Y		E	V	E	N		A	F	T	E	R
	T	H	R	E	S	H	O	L	D	:			X	X	X

Where: **XXX** = YES or NO.

- Press the CYCLE NUMBER push-button and select YES if relay R2 must operate only after the run-up time or select NO when the R2 operation is needed right from start of the turbopump and after the rotational speed of the turbopump exceeds for the first time the speed threshold value (see the preceding cycle diagram).

This function is factory-set to YES.

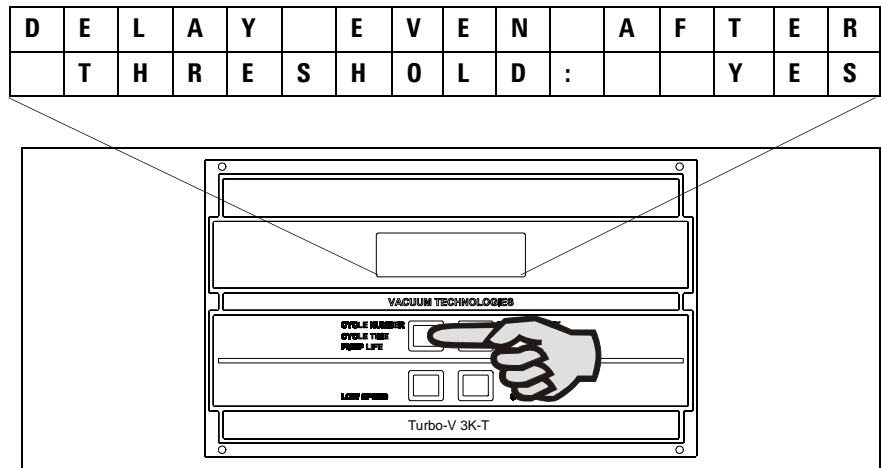

Figure 33

Press the PUMP CURRENT push-button and the display shows:

V	E	N	T		V	A	L	V	E		M	O	D	E	
			X	X	X	X	X	X	X						

where: **XXX** = CONTROLLED VENT or SERIAL COMMAND

- Press the PUMP CURRENT push-button. If VENT VALVE MODE = AUTO MODE, the display shows:

V	E	N	T		V	A	L	V	E		D	E	L	A	Y
					X	X	X	X	X		S				

Delay time of the vent valve from 0 to 999999

- Press the PUMP CURRENT push-button. If VENT VALVE MODE = AUTO MODE, the display shows:

	V	E	N	T		O	P	E	N		T	I	M	E	
X	X	X	X	X		S			0	=	I	N	F		

17 Technical Information

Use

- Press PUMP CURRENT push-button and the display shows:

			S	T	O	P		S	P	E	E	D			
		R	E	A	D	I	N	G		:		X	X	X	

where: **XXX** = YES or NO.

- Press PUMP CURRENT to confirm. and the display shows:

P	U	M	P		L	I	F	E		X	X	X	X	X	h
			R	E	S	E	T	?		X	X	X			

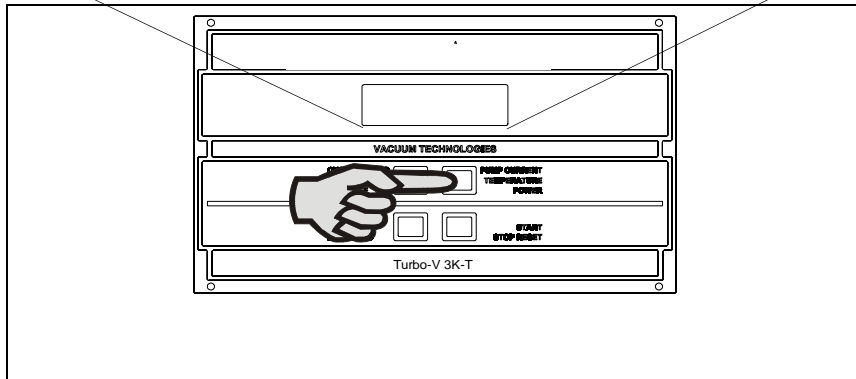

Figure 34

Where:

- PUMP LIFE** = is the elapsed operating time range 000 to 99999 hours.
- RESET XXX** = YES or NO.

The controller is factory-set to NO.

NOTE

When PUMP LIFE is reset to 000, the CYCLE number is also reset to 000.

Starting the Pump

If the forepump and vent device are not operated by the controller, close the vent valve and switch on the forepump.

NOTE

Before starting the pump the cooling mode must be selected.

NOTE

With the FRONT panel operation selected, the REMOTE and RS 232/485 operations are inoperative; conversely, the CYCLE NUMBER and PUMP CURRENT push-buttons are always active, even when the operating mode selected is REMOTE or RS 232/485.

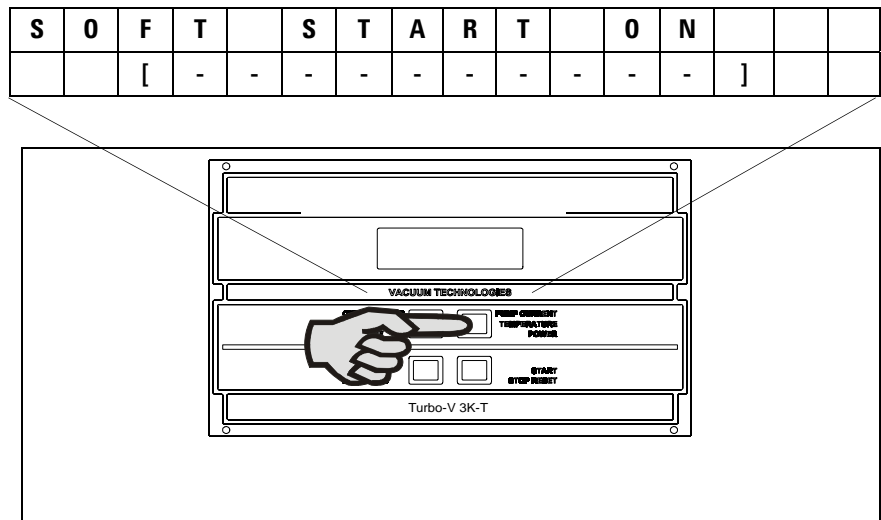

Figure 35

Where the sign minus (-) become a square (□) when the pump finish the ramp-up step. The active step is indicated by a flashing square (◻).

17 Technical Information

Use

As the ten steps are fully covered, the pump will reach the Normal operation. If during the Soft Start mode the power drawn by the pump exceed 200 W the speed of the pump is decreased to maintain the maximum power allowable (200 W).

- If the Soft Start mode has been deselected the display will change and shows:

P	U	M	P		I	S		S	T	A	R	T	I	N	G
1	2		X	X	X		H	z		H	J		H	S	

where:

1 2 = contrast inverted identifies the set point condition:

- **1** is displayed when relay R1 is de-energized and the related output is zero voltage.
- **2** is displayed when relay R2 is energized and the related output is 24V.

XX Hz = indicates the actual theoretical rotational speed of the pump as a function of the controller output frequency.

HJ = displayed only when the heater jacket is active.

HS/HL = indicates that the pump is working in the High speed or Low speed mode.

After START command, frequency output will be at the maximum level, then the frequency will decrease to a value proportional to the pump rotational speed (about 3 Hz if the pump is completely stopped).

The pump will accelerate to its normal rotational speed.

- During acceleration of the pump or during any operating condition, it is always possible to select the other parameters to be displayed pressing the PUMP CURRENT or the CYCLE NUMBER pushbuttons.
- After the run up time and when the normal rotational speed is reached, the display will be as follows, even if any previous display selection was made, and the normal condition has been reached.

N	O	R	M	A	L		O	P	E	R	A	T	I	O	N
1	2		X	X	X		H	z		H	J		H	S	

where: **XX** = indicates the rotational speed (36 Hz for high speed, or 22 Hz for low speed).

Operating the Pump

After the starting period, if the system has a vacuum leak or the pressure in the pump chamber is high (from 1 mbar to atmosphere), the pump continues to operate indefinitely. If the gas load at the turbopump inlet flange continues to stay high, the power drawn by the turbopump increases up to the maximum value.

Then the Turbo-V 3K-T pump is slowed down in proportion to the gas load at least until it reaches about 4 or 3 Hz.

As soon as the gas load decreases, the pump will automatically accelerate to reach normal operation. The pump can be stopped at any rotational speed and can be restarted at any rotational speed from either the front panel buttons or the remote connections. The controller automatically synchronizes the output to the rotational speed of the pump and then accelerates linearly up to the nominal speed or within steps if the Soft Start has been selected.

Pump Shutdown

Press the front panel STOP push-button or remove the remote signal; the power from the turbopump will be removed and the pump will begin to slow down.

Power Failure

In the event of a power failure (momentary or long term), the Turbo-V 3K-T controller will stop the turbopump and all the interconnected pumps/devices. The Turbo-V 3K-T vent valve dev3KT, if used, will vent the turbopump only if the power failure is longer than the preset delay time. When power is restored, the Turbo-V 3K-T controller automatically restarts the interconnected dev3KTs and the turbopump in the proper sequence.

The display shows:

P	U	M	P		I	S		S	T	A	R	T	I	N	G
1	2		X	X	X		H	z		H	J		H	S	

until normal operation achieved.

Remote Control Mode Operation

If remote signals are used to operate the controller, it must be programmed for remote operation (see paragraph "Operating parameter selections") and when ready to start, the display shows:

R	E	A	D	Y		F	O	R		R	E	M	O	T	E
S	O	F	T		S	T	A	R	T					H	S

If the Soft Start has been deselected the display shows:

P	U	M	P		R	E	A	D	Y	:		U	S	E	
	R	E	M	O	T	E		S	T	A	R	T		H	S

With or without Soft Start mode selected the START/STOP and LOW SPEED front panel push- buttons are inoperative, while the CYCLE NUMBER and PUMP CURRENT pushbuttons are always active.

RS 232/485 Control Mode Operation

If the RS 232 option is installed and the controller has been programmed for RS 232 operation, the controller may be driven by a computer and when ready to operate, the display shows:

P	U	M	P		R	E	A	D	Y	:		U	S	E	
	R	S	2	3	2		L	I	N	E				H	S

If the Soft Start has been deselected the display shows:

R	E	A	D	Y		F	O	R		R	S	2	3	2	
S	O	F	T		S	T	A	R	T					H	S

The value which corresponds to the board installed will be assigned to RSXXX

With or without Soft Start mode selected the START/STOP, LOW SPEED functions are under computer control, while the CYCLE NUMBER and PUMP CURRENT front panel pushbuttons are always active.

Orderable Parts

Tab. 7

Description	Part number
Turbo-V 3K-T Rack Controller 120 V	869-9547
Turbo-V 3K-T Rack Controller 220 V	869-9447
Pump-controller connection cable	969-9953
Turbo-V 3K-T Rack valves cable (5 m)	969-9938
RS 485 computer communication kit	969-9856
RS 232 computer communication kit	969-9857



Agilent Technologies

Vacuum Products Division

Dear Customer,

Thank you for purchasing an Agilent vacuum product. At Agilent Vacuum Products Division we make every effort to ensure that you will be satisfied with the product and/or service you have purchased.

As part of our Continuous Improvement effort, we ask that you report to us any problem you may have had with the purchase or operation of our products. On the back side you find a Corrective Action request form that you may fill out in the first part and return to us.

This form is intended to supplement normal lines of communications and to resolve problems that existing systems are not addressing in an adequate or timely manner.

Upon receipt of your Corrective Action Request we will determine the Root Cause of the problem and take the necessary actions to eliminate it. You will be contacted by one of our employees who will review the problem with you and update you, with the second part of the same form, on our actions.

Your business is very important to us. Please, take the time and let us know how we can improve.

Sincerely,

Giampaolo LEVI

***Vice President and General Manager
Agilent Vacuum Products Division***

Note: Fax or mail the Customer Request for Action (see backside page) to Agilent Vacuum Products Division (Torino) – Quality Assurance or to your nearest Agilent representative for onward transmission to the same address.

CUSTOMER REQUEST FOR CORRECTIVE / PREVENTIVE / IMPROVEMENT ACTION

TO: AGILENT VACUUM PRODUCTS DIVISION TORINO – QUALITY ASSURANCE

FAX N°: XXXX-011-9979350

ADDRESS: AGILENT TECHNOLOGIES ITALIA S.p.A. – Vacuum Products Division –

Via F.lli Varian, 54 – 10040 Leinì (TO) – Italy

E-MAIL: vpd-qualityassurance_pdl-ext@agilent.com

NAME _____	COMPANY _____	FUNCTION _____
ADDRESS: _____		
TEL. N° : _____ FAX N° : _____		
E-MAIL: _____		
PROBLEM / SUGGESTION : _____ _____ _____ _____		
REFERENCE INFORMATION (model n°, serial n°, ordering information, time to failure after installation, etc.): _____ _____ _____ DATE _____		
CORRECTIVE ACTION PLAN / ACTUATION (by AGILENT VPD) _____ _____ _____ _____ _____		LOG N° _____

XXX = Code for dialing Italy from your country (es. 01139 from USA; 00139 from Japan, etc.)



**Vacuum Products Division
Instructions for returning products**

Dear Customer:

Please follow these instructions whenever one of our products needs to be returned.

1) Complete the attached Request for Return form and send it to Agilent Technologies (see below), taking particular care to identify all products that have pumped or been exposed to any toxic or hazardous materials.

2) After evaluating the information, Agilent Technologies will provide you with a Return Authorization (RA) number via email or fax, as requested.

Note: Depending on the type of return, a Purchase Order may be required at the time the Request for Return is submitted. We will quote any necessary services (evaluation, repair, special cleaning, eg).

3) Important steps for the shipment of returning product:

- Remove all accessories from the core product (e.g. inlet screens, vent valves).
- Prior to shipment, drain any oils or other liquids, purge or flush all gasses, and wipe off any excess residue.
- If ordering an Advance Exchange product, **please use the packaging from the Advance Exchange to return the defective product.**
- Seal the product in a plastic bag, and package product carefully to avoid damage in transit. You are responsible for loss or damage in transit.
- Agilent Technologies is not responsible for returning customer provided packaging or containers.
- **Clearly label package with RA number.** Using the shipping label provided will ensure the proper address and RA number are on the package. Packages shipped to Agilent without a RA clearly written on the outside cannot be accepted and will be returned.

4) Return only products for which the RA was issued.

5) **Product being returned under a RA must be received within 15 business days.**

6) **Ship to the location specified on the printable label, which will be sent, along with the RA number, as soon as we have received all of the required information.** Customer is responsible for freight charges on returning product.

7) Return shipments must comply with all applicable **Shipping Regulations** (IATA, DOT, etc.) and carrier requirements.

RETURN THE COMPLETED **REQUEST FOR RETURN** FORM TO YOUR NEAREST LOCATION:

EUROPE:

Fax: 00 39 011 9979 330
Fax Free: 00 800 345 345 00
Toll Free: 00 800 234 234 00
vpt-customer@agilent.com

NORTH AMERICA:

Fax: 1 781 860 9252
Toll Free: 800 882 7426, Option 3
vpl-ra@agilent.com

PACIFIC RIM:

please visit our website for individual office information
<http://www.agilent.com>



Please read important policy information on Page 3 that applies to all returns.

1) CUSTOMER INFORMATION

Form with fields for Company Name, Contact Name, Tel, Email, Fax, Customer Ship To, Customer Bill To, and VAT/USA/Canada tax information.

2) PRODUCT IDENTIFICATION

Table with 4 columns: Product Description, Agilent P/N, Agilent S/N, Original Purchasing Reference.

3) TYPE OF RETURN (Choose one from each row and supply Purchase Order if requesting a billable service)

- 3A. [] Non-Billable [] Billable -> New PO # (hard copy must be submitted with this form):
3B. [] Exchange [] Repair [] Upgrade [] Consignment/Demo [] Calibration [] Evaluation [] Return for Credit

4) HEALTH and SAFETY CERTIFICATION

Agilent Technologies CANNOT ACCEPT ANY PRODUCTS CONTAMINATED WITH BIOLOGICAL OR EXPLOSIVE HAZARDS, RADIOACTIVE MATERIAL, OR MERCURY AT ITS FACILITY. Call Agilent Technologies to discuss alternatives if this requirement presents a problem. The equipment listed above (check one): [] HAS NOT pumped or been exposed to any toxic or hazardous materials. OR [] HAS pumped or been exposed to the following toxic or hazardous materials. If this box is checked, the following information must also be filled out. Check boxes for all materials to which product(s) pumped or was exposed: [] Toxic [] Corrosive [] Reactive [] Flammable [] Explosive [] Biological [] Radioactive. List all toxic/hazardous materials. Include product name, chemical name, and chemical symbol or formula: NOTE: If a product is received at Agilent which is contaminated with a toxic or hazardous material that was not disclosed, the customer will be held responsible for all costs incurred to ensure the safe handling of the product, and is liable for any harm or injury to Agilent employees as well as to any third party occurring as a result of exposure to toxic or hazardous materials present in the product. Print Name: Authorized Signature: Date:

5) FAILURE INFORMATION:

Failure Mode (REQUIRED FIELD. See next page for suggestions of failure terms):
Detailed Description of Malfunction: (Please provide the error message)
Application (system and model):

I understand and agree to the terms of Section 6, Page 3/3.
Print Name: Authorized Signature: Date:



Vacuum Products Division
Request for Return Form
(Health and Safety Certification)

Please use these Failure Mode to describe the concern about the product on Page 2.

TURBO PUMPS and TURBO CONTROLLERS

Table with 3 columns: APPARENT DEFECT/MALFUNCTION, POSITION, and PARAMETERS. Lists various failure modes like 'Does not start', 'Noise', 'Vertical', 'Horizontal', etc.

ION PUMPS/CONTROLLERS

Table listing failure modes for Ion Pumps/Controllers: Bad feedthrough, Vacuum leak, Error code on display, Poor vacuum, High voltage problem, Other.

VALVES/COMPONENTS

Table listing failure modes for Valves/Components: Main seal leak, Solenoid failure, Damaged sealing area, Bellows leak, Damaged flange, Other.

LEAK DETECTORS

Table listing failure modes for Leak Detectors: Cannot calibrate, Vacuum system unstable, Failed to start, No zero/high background, Cannot reach test mode, Other.

INSTRUMENTS

Table listing failure modes for Instruments: Gauge tube not working, Communication failure, Error code on display, Display problem, Degas not working, Other.

SCROLL AND ROTARY VANE PUMPS

Table listing failure modes for Scroll and Rotary Vane Pumps: Pump doesn't start, Doesn't reach vacuum, Pump seized, Noisy pump (describe), Over temperature, Other.

DIFFUSION PUMPS

Table listing failure modes for Diffusion Pumps: Heater failure, Doesn't reach vacuum, Vacuum leak, Electrical problem, Cooling coil damage, Other.

Section 6) ADDITIONAL TERMS

Please read the terms and conditions below as they apply to all returns and are in addition to the Agilent Technologies Vacuum Product Division – Products and Services Terms of Sale.

- Customer is responsible for the freight charges for the returning product. Return shipments must comply with all applicable Shipping Regulations (IATA, DOT, etc.) and carrier requirements.
Customers receiving an Advance Exchange product agree to return the defective, rebuildable part to Agilent Technologies within 15 business days. Failure to do so, or returning a non-rebuildable part (crashed), will result in an invoice for the non-returned/non-rebuildable part.
Returns for credit toward the purchase of new or refurbished Products are subject to prior Agilent approval and may incur a restocking fee. Please reference the original purchase order number.
Units returned for evaluation will be evaluated, and a quote for repair will be issued. If you choose to have the unit repaired, the cost of the evaluation will be deducted from the final repair pricing. A Purchase Order for the final repair price should be issued within 3 weeks of quotation date. Units without a Purchase Order for repair will be returned to the customer, and the evaluation fee will be invoiced.
A Special Cleaning fee will apply to all exposed products per Section 4 of this document.
If requesting a calibration service, units must be functionally capable of being calibrated.

Sales and Service Offices

United States

**Agilent Technologies
Vacuum Products Division**
121 Hartwell Avenue
Lexington, MA 02421 - USA
Tel.: +1 781 861 7200
Fax: +1 781 860 5437
Toll-Free: +1 800 882 7426

Benelux

**Agilent Technologies Netherlands B.V.
Vacuum Products Division**
Herculesweg 8
4338 PL Middelburg
The Netherlands
Tel.: +31 118 671570
Fax: +31 118 671569
Toll-Free: 00 800 234 234 00

Canada

**Central coordination through: Agilent Technologies
Vacuum Products Division**
121 Hartwell Avenue
Lexington, MA 02421 - USA
Tel.: +1 781 861 7200
Fax: +1 781 860 5437
Toll-Free: +1 800 882 7426

China

**Agilent Technologies (China) Co. Ltd
Vacuum Products Division**
No.3, Wang Jing Bei Lu,
Chao Yang District,
Beijing, 100102
China
Tel.: +86 (10) 6439 7718
Toll-Free: 800 820 6556

France

**Agilent Technologies France
Vacuum Products Division**
7 Avenue des Tropiques
Z.A. de Courtaboeuf - B.P. 12
91941 Les Ulis cedex - France
Tel.: +33 (0) 1 69 86 38 84
Fax: +33 (0) 1 69 86 29 88
Toll free: 00 800 234 234 00

Germany and Austria

**Agilent Technologies
Vacuum Products Division**
Alsfelder Strasse 6 Postfach 11
14 35
64289 Darmstadt – Germany
Tel.: +49 (0) 6151 703 353
Fax: +49 (0) 6151 703 302
Toll free: 00 800 234 234 00

India

**Agilent Technologies India Pvt. Ltd.
Vacuum Product Division**
G01. Prime corporate Park,
230/231, Sahar Road, Opp. Blue Dart Centre,
Andheri (East), Mumbai – 400 099.India
Tel: +91 22 30648287/8200
Fax: +91 22 30648250
Toll Free: 1800 113037

Italy

**Agilent Technologies Italia S.p.A.
Vacuum Products Division**
Via F.lli Varian, 54
10040 Leini, (Torino) - Italy
Tel.: +39 011 997 9111 Fax: +39 011 997 9350
Toll-Free: 00 800 234 234 00

Japan

**Agilent Technologies Japan, Ltd.
Vacuum Products Division**
8th Floor Sumitomo Shibaura Building
4-16-36 Shibaura Minato-ku Tokyo 108-0023 - Japan
Tel.: +81 3 5232 1253
Fax: +81 3 5232 1710
Toll-Free: 0120 655 040

Korea

**Agilent Technologies Korea, Ltd.
Vacuum Products Division**
Shinsa 2nd Bldg. 2F 966-5 Daechi-dong
Kangnam-gu, Seoul
Korea 135-280
Tel.: +82 2 3452 2452
Fax: +82 2 3452 2451
Toll-Free: 080 222 2452

Mexico

**Agilent Technologies
Vacuum Products Division**
Concepcion Beistegui No 109 Col Del Valle
C.P. 03100 – Mexico, D.F.
Tel.: +52 5 523 9465
Fax: +52 5 523 9472

Singapore

**Agilent Technologies Singapore Pte. Ltd,
Vacuum Products Division**
Agilent Technologies Building,
1 Yishun Avenue 7,
Singapore 768923
Tel : (65) 6215 8045
Fax : (65) 6754 0574

Southeast Asia

**Agilent Technologies Sales Sdn Bhd
Vacuum Products Division**
Unit 201, Level 2 uptown 2,
2 Jalan SS21/37, Damansara Uptown
47400 Petaling Jaya,
Selangor, Malaysia
Tel : +603 7712 6106
Fax: +603 6733 8121

Taiwan

**Agilent Technologies Taiwan Limited
Vacuum Products Division (3F)**
20 Kao-Shuang Rd.,
Pin-Chen City, 324
Taoyuan Hsien , Taiwan, R.O.C.
Tel. +886 34959281
Toll Free: 0800 051 342

UK and Ireland

**Agilent Technologies UK, Ltd.
Vacuum Products Division**
6 Mead Road Oxford Industrial Park
Yarnton, Oxford OX5 1QU – UK
Tel.: +44 (0) 1865 291570
Fax: +44 (0) 1865 291571
Toll free: 00 800 234 234 00

Other Countries

**Agilent Technologies Italia S.p.A.
Vacuum Products Division**
Via F.lli Varian, 54 10040 Leini, (Torino) -
Italy
Tel.: +39 011 997 9111
Fax: +39 011 997 9350
Toll-Free: 00 800 234 234 00

Customer Support & Service

NORTH AMERICA:

Toll Free: 800 882 7426, Option 3
vpl-ra@agilent.com

EUROPE:

Toll Free: 00 800 234 234 00
vpt-customer@agilent.com

PACIFIC RIM:

please visit our website for individual office
information <http://www.agilent.com>

Worldwide Web Site, Catalog and Order

On-line:

www.agilent.com
Representative in most countries
12/10

© Agilent Technologies, Inc. 2011

Printed in ITALY

11/2011

Publication Number: 87-900-988-01 (D)



Agilent Technologies