

Vacuum Technology

Vacuum Process  
Engineering

Measuring and  
Analytical Technology



LEYBOLD  
VACUUM PRODUCTS INC.

Part Number 722-78-001 ■ Edition L



FOR SALES AND SERVICE PLEASE CALL:

**PTB SALES** T :: 626.334.0500  
service@ptbsales.com  
www.ptbsales.com

DATE SERVICED: \_\_\_\_\_

**VIEW OUR INVENTORY**

# TRIVAC<sup>®</sup> "A" Dual Stage Rotary Vane Pump MANUAL

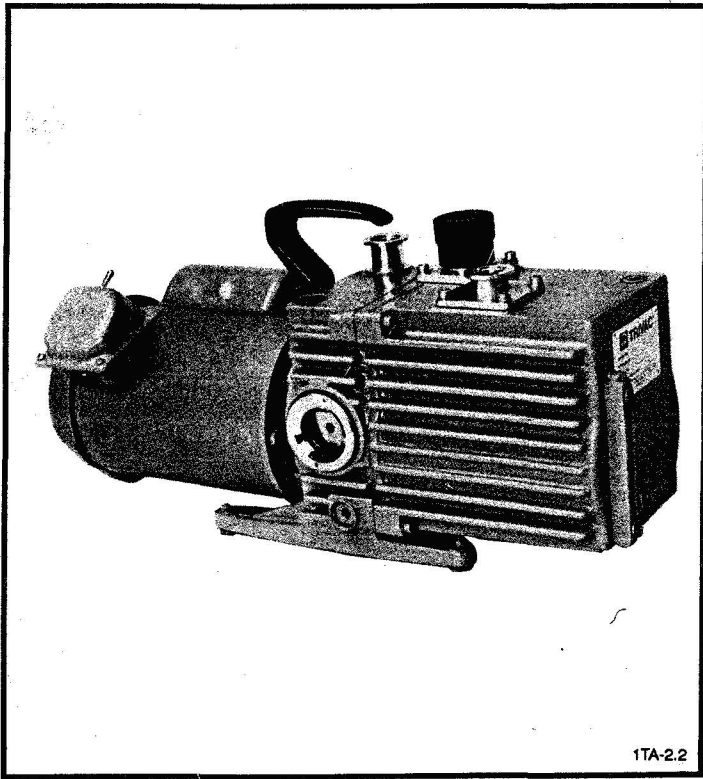

1TA-2.2

Manufactured in the United States

## LIMITED WARRANTY

Seller warrants to the original purchaser that the equipment to be delivered pursuant to this Agreement will be as described herein and will be free from defects in material or workmanship. Minor deviations which do not affect the performance of the equipment shall not be deemed to constitute either a failure to conform to the specifications or a defect in material or workmanship.

This warranty shall extend for a period of twelve (12) months from the initial date of shipment. Should any failure of conformity to this warranty appear within twelve (12) months from the initial date of shipment, Seller shall, upon immediate notification of such alleged failure and substantiation that the equipment has been operated and maintained in accordance with Seller's recommendations and standard industry practices, correct such defects by suitable repair or replacement at its own expense.

Seller's liability under this warranty shall cease if any major repairs to or any replacement or modification of the equipment is made by any person other than Seller's personnel or persons working under the supervision of Seller's personnel, unless authorized by Seller in writing. Further, the warranty shall cease unless the Buyer has operated the equipment in strict compliance with operating instructions and manuals, if any, provided for the equipment, and unless Buyer operates the equipment in normal use and with proper maintenance.

If the equipment contains components from another manufacturer and are subject to the manufacturer's warranty, then Seller's liability shall be limited to the extent of the warranty which Seller received from the manufacturer or supplier of the equipment component parts. Seller's liability shall be no greater than the liability of the manufacturer or supplier as determined by a final judgment by the Buyer against the manufacturer or supplier of such components. Seller will cooperate with Buyer in such legal action but at Buyer's expense.

THIS WARRANTY IS EXPRESSLY IN LIEU OF ANY AND ALL REPRESENTATIONS AND WARRANTIES, EXPRESS OR IMPLIED, INCLUDING ANY WARRANTY OF MERCHANTABILITY, FITNESS FOR A PARTICULAR PURPOSE OR OTHER WARRANTY OF QUALITY, EXCEPT THE WARRANTY OF TITLE. THIS WARRANTY CONSTITUTES THE EXCLUSIVE REMEDY, and shall not be deemed to have failed of its essential purpose so long as Seller is willing and able to correct defects covered by the warranty in the manner prescribed. The sole purpose of the exclusive remedy shall be to provide Buyer with free repair and/or replacement in the manner and for the time period provided herein.

The entire agreement between the parties is embodied in this writing, which constitutes the final expression of the parties, and it is the complete and exclusive statement of the terms of the agreement. No other warranties are given beyond those set out in this writing.

LIMITATION OF LIABILITY. SELLER SHALL NOT, UNDER ANY CIRCUMSTANCES, BE LIABLE FOR DIRECT OR INDIRECT, SPECIAL DAMAGES, INCIDENTAL OR CONSEQUENTIAL, such as but not limited to, loss of profits, damage to or loss of other property, downtime costs of the equipment, delay expenses, overhead or capital costs, claims of Buyer's customers or activities dependent upon the equipment.

Except to the extent provided in the LIMITED WARRANTY, Seller shall not be liable for any claim or loss arising out of or related to this agreement or the equipment provided pursuant thereto, whether such claim allegedly arises or is based on contract, warranty, tort (including negligence), strict liability in tort or otherwise. Liability shall not in any event exceed the cost of the equipment upon which such liability is based.

SEVERABILITY. If any portion or clause of this agreement is held invalid or unenforceable as to any person or under any circumstances, the invalidity or lack of application shall not impair or affect the other provisions and the application of those provisions which can be given effect without the invalid or unenforceable provision or application. With this intention, the provisions of this agreement are declared to be severable.

| Pump Model  | D2A                | D4A                | D8A                | D16A               | D30A               | D60A               | D90A               |
|---|--------------------|--------------------|--------------------|--------------------|--------------------|--------------------|--------------------|
| Displacement . . . . CFM  | 2.2                | 4.5                | 7.0                | 14.1               | 26.8               | 36.7               | 53.7               |
| Displacement . . . . liters/minute  | 62.5               | 127                | 190                | 400                | 760                | 1030               | 1520               |
| Ultimate partial pressure . . . . Torr  | $3 \times 10^{-4}$ | $3 \times 10^{-4}$ | $3 \times 10^{-4}$ | $3 \times 10^{-4}$ | $3 \times 10^{-4}$ | $3 \times 10^{-4}$ | $3 \times 10^{-4}$ |
| Ultimate pressure with gas ballast . . . . Torr                                   | $3 \times 10^{-3}$ | $3 \times 10^{-3}$ | $3 \times 10^{-3}$ | $3 \times 10^{-3}$ | $3 \times 10^{-3}$ | $5 \times 10^{-3}$ | $5 \times 10^{-3}$ |
| Water vapor tolerance . . . . Torr  | 30                 | 15                 | 30                 | 15                 | 40                 | 20                 | 20                 |
| Oil Capacity . . . . . quarts (Hydrocarbon)<br>. . . . . lbs (perfluoropolyether) | 0.5<br>2.5         | 0.75<br>3          | 1<br>4.2           | 1.25<br>5          | 3.5<br>13.7        | 4<br>16.8          | 4<br>16.8          |
| Motor power . . . . hp  | 1/3                | 1/3                | 1                  | 1                  | 1-1/2              | 2.0                | 3.0                |
| Pump rotational speed . . . . RPM   | 1725               | 1725               | 1725               | 1725               | 1725               | 1150               | 1725               |
| Weight complete . . . . lb  | 41                 | 45                 | 80                 | 85                 | 163                | 210                | 210                |
| Sound pressure level (max) at three feet with<br>gas ballast closed . . . . dB(A) | 50                 | 50                 | 60                 | 62                 | 59                 | 60                 | 60                 |
| Sound pressure level (ave) at three feet with<br>gas ballast open . . . . dB(A)   | 54                 | 56                 | 57                 | 60                 | 62                 | 63                 | 63                 |
| Intake tube and exhaust port diameter . . . . mm                                  | KF 16              | KF 16              | KF 25              | KF 25              | KF 40              | KF 40              | KF 40              |
| Maximum ambient temperature   | 104°F (40°C)       |                    |                    |                    |                    |                    |                    |

## WARNINGS:



Death or serious injury can result from the improper use or application of this pump. If the pump will be exposed to toxic, explosive, pyrophoric, highly corrosive, or other hazardous process gases including greater than atmospheric concentrations of oxygen, contact Leybold for specific recommendations.



Ground the motor properly during installation. Disconnect the power before beginning installation, maintenance, or repair work or before interchanging the input leads when correcting the direction of rotation. Disconnecting the power also avoids an unexpected start-up for pumps with automatically resetting thermal overloads. Most of our single-phase motors have automatically resetting thermal overloads.



Don't run the pump without an exhaust line and an adequate exhaust system if hazardous gases or vapors are expelled from the pump.

Don't exceed a maximum back pressure of 7 psig. Excessive pressure in the pump could damage the seals, blow out the sight glass, or rupture the pump housing. In addition, excessive backpressure can result in hazardous process gas or contaminated oil leaking out of the pump. Don't install an exhaust line with a smaller ID than the exhaust port or allow restrictions or deposit buildup in the exhaust line. If you are purging the oil casing with inert gas, limit the inert-gas flow to avoid exceeding the 7 psig limit.



Hazardous process gases can concentrate in the vacuum pump, its oil, and its filters. If the pump has been used on toxic, explosive, pyrophoric, corrosive, volatile, or other hazardous substances, take the proper safety precautions before opening the pump or filters. Proper precautions could include inert gas purging before and after you drain the oil to sweep hazardous gas from the pump or filters; gloves or protective clothing to avoid skin contact with toxic or highly corrosive substances; specially ventilated work areas; fume hoods, safety masks; breathing apparatus; etc.

Before sending any equipment to our factory or to one of our service centers, notify us of any toxic or other harmful products that may be in the pump, its oil, or its filters. You will also need to supply us with the pump's serial and catalog numbers from the ID plate on the end of the oil casing (see Figure 1-1).

# CONTENTS

| Section  | Title  | Page |
|--|--|------|
| SECTION 1 – INTRODUCTION                                     |  | 3    |
| 1-1  | Manual Key   | 3    |
| 1-2  | Model and Catalog Numbers                                | 3    |
| SECTION 2 – PRINCIPLES OF OPERATION                          |  | 4    |
| 2-1  | Direct Drive Mechanism                                   | 4    |
| 2-2  | Pumping Mechanism  | 4    |
| 2-2-1  | High Vacuum Stage Pump Cylinder                          | 4    |
| 2-2-2  | Second Stage Pump Cylinder                               | 5    |
| 2-3  | Gas Ballast Mechanism                                    | 5    |
| 2-3-1  | Opening and Closing the Valve                            | 5    |
| 2-3-2  | Purpose and Function                                     | 6    |
| 2-4  | Lubricating Fluid  | 7    |
| 2-5  | Anti-Suck Back Mechanism                                 | 8    |
| SECTION 3 – PREPARING AND INSTALLING THE PUMP                |  | 8    |
| 3-1  | Receiving  | 8    |
| 3-1-1  | Reporting Shipping Damage                                | 8    |
| 3-1-2  | Reporting Shipping Shortage                              | 8    |
| 3-1-3  | Reporting Incorrect Shipment                             | 9    |
| 3-2  | Initial Filling With Lubricating Fluid                   | 9    |
| 3-3  | Connecting the Pump to the System                        | 9    |
| 3-4  | Making the Electrical Connection                         | 10   |
| SECTION 4 – STARTING, OPERATING, AND MAINTAINING THE PUMP    |  | 10   |
| 4-1  | Start-up   | 10   |
| 4-1-1  | Checking the Direction of Rotation                       | 10   |
| 4-1-2  | Using the Gas Ballast Valve During Pump Warm-up          | 10   |
| 4-2  | Operation  | 11   |
| 4-3  | Preventative Maintenance                                 | 11   |
| 4-3-1  | Checking the Lubricating Fluid Level                     | 11   |
| 4-3-2  | Changing the Lubricating Fluid                           | 12   |
| 4-3-3  | Checking the Lubricating Fluid for Contamination         | 13   |
| 4-3-4  | Long Term Storage  | 13   |
| 4-3-5  | Checking the Dirt Trap                                   | 13   |
| 4-3-6  | Avoiding Oil Leaks During Shipping and Storage           | 13   |
| SECTION 5 – DISASSEMBLY, CLEANING, AND ASSEMBLY INSTRUCTIONS |  | 14   |
|  | Module Replacement Procedure                             | 14   |
| 5-A  | Required Materials and Tools                             | 14   |
| 5-A-1  | Required Materials                                       | 14   |
| 5-A-2  | Required Tools   | 14   |
| 5-B  | Removing the Module from the Pump                        | 15   |
| 5-C  | Disassembling the Module                                 | 17   |
| 5-D  | Disassembling the Remaining Parts                        | 22   |
| 5-E  | Cleaning and Inspecting the Disassembled Pump            | 28   |
| 5-E-1  | Special Requirements for Extreme-Corrosive Service Pumps | 28   |
| 5-E-2  | Instructions for Cleaning and Inspecting all Pump Models | 28   |
| 5-F  | Reassembling the Pump                                    | 29   |
| SECTION 6 – TROUBLESHOOTING                                  |  | 43   |
| SECTION 7 – PARTS LIST                                       |  | 55   |



## LIST OF TABLES

| Table   | Title   | Page |
|---|---|------|
| <b>SECTION 4 – STARTING, OPERATING, AND MAINTAINING THE PUMP</b>    |   |      |
| 4-1   | Technical Data . . . . .  | 12   |
| <b>SECTION 5 – DISASSEMBLY, CLEANING, AND ASSEMBLY INSTRUCTIONS</b> |   |      |
| 5-1   | Rotor, Bearing, Shaft, and Vane Critical Dimensions . . . . .   | 30   |
| 5-2   | Parts Required for Installing Rotational Lock Bearing . . . . . | 32   |
| <b>SECTION 6 – TROUBLESHOOTING</b>                                  |   |      |
| 6-1   | Troubleshooting Chart . . . . .                                 | 43   |

## LIST OF FIGURES

| Figure  | Title   | Page |
|---|---|------|
| <b>SECTION 1 – INTRODUCTION</b>   |   |      |
| Sketch 1-1 Pump Identification Plate . . . . .  |   | 3    |
| 1-1   | Location of the Identification Plate, the Oil Fill Ports and the Oil Drain Ports . . . . .                                  | 4    |
| <b>SECTION 2 – PRINCIPLES OF OPERATION</b>  |   |      |
| Sketch 2-1 Cross Section of the Gas Ballast Valve on the D8A/AC through D90A/AC Extreme-Corrosive Service Pumps . . . . . |   | 7    |
| 2-1   | D4A Module. . . . .   | 5    |
| 2-2   | High Vacuum Stage Pump Cylinder with Rear End Plate Removed . . . . .   | 5    |
| 2-3   | Gas Ballast Valve and Second Stage Pump Cylinder with Front End Plate Removed . . . . .                                     | 6    |
| <b>SECTION 5 – DISASSEMBLY, CLEANING, AND ASSEMBLY INSTRUCTIONS</b>   |   |      |
| 5-1   | Assembled Pump (D16A Pump Model Shown) . . . . .  | 16   |
| 5-2   | Module Attached to Coupling Housing (D2A Pump Model Shown) . . . . .  | 17   |
| 5-3   | Module, Side View (D2A Pump Model Shown) . . . . .  | 18   |
| 5-4   | Front End of Module Minus Coupling and Centrifugal Switch (D2A Pump Model Shown) . . . . .                                  | 19   |
| 5-5   | Removing the Cylindrical Pins from the Module (D2A Pump Model Shown) . . . . .  | 20   |
| 5-6   | Rear End of Module Minus the Disk (D2A Pump Model Shown) . . . . .  | 20   |
| 5-7   | High Vacuum Stage Pump Cylinder (D2A Pump Model Shown) . . . . .  | 21   |
| 5-8   | Second Stage Pump Cylinder (D2A Pump Model Shown) . . . . .   | 21   |
| 5-9   | High Vacuum Stage Rotor Removed from the Shaft (D2A Pump Model Shown) . . . . .   | 22   |
| 5-10A   | Cap End of Gas Ballast Valve . . . . .  | 23   |
| 5-10B   | Tube End of Gas Ballast Valve . . . . .   | 23   |
| 5-11  | Miscellaneous Disassembled Parts . . . . .  | 24   |
| 5-12  | Removing the Radial Shaft Seal from the End Plates (D2A Pump Model Shown) . . . . .   | 25   |
| 5-13  | D4A Module Showing Retaining Bracket and Valve Plate . . . . .  | 25   |
| 5-14  | Removing the Valve Stop and Plate (D2A Pump Model Shown) . . . . .  | 26   |
| 5-15  | Coupling Housing and Motor (D2A Pump Model Shown) . . . . .   | 26   |
| 5-16  | Removing the Oil Level Glass from the Coupling Housing (D2A Pump Model Shown) . . . . .                                     | 27   |
| 5-17  | Disassembled Motor (D30A Motor Shown) . . . . .   | 32   |
| 5-18  | Rotors/Shaft/Center Bearing Plate Assembly (D2A Pump Model Shown) . . . . .   | 35   |
| 5-19  | Driving the Long Cylindrical Pins that Align the HV Stage Cylinder and the Center Bearing (D2A Pump Model Shown) . . . . .  | 36   |
| 5-20  | Pulling the Second Stage Cylinder Tight Against the Center Bearing (D2A Pump Model Shown) . . . . .                         | 38   |
| 5-21  | Driving the Short Cylindrical Pins that Align the Rear End Plate and the HV Stage Cylinder (D2A Pump Model Shown) . . . . . | 39   |
| 5-22  | Using a Shaft Sleeve to Install the Radial Shaft Seal into the Front End Plate (D2A Pump Model Shown) . . . . .             | 40   |
| 5-23  | Reassembling the Module to the Coupling Housing . . . . .   | 42   |
| <b>SECTION 7 – SPARE PARTS LIST</b>   |   |      |
| 7-1   | Disassembled Pump (D2A Pump Model Shown) . . . . .  | 56   |
| 7-2   | Exploded Isometric Drawing of a D30A Pump Model . . . . .   | 73   |

# SECTION 1

## INTRODUCTION

This manual contains important information regarding the safe operation, maintenance, and repair of your TRIVAC dual-stage pump. We urge you to read Sections 1, 3, and 4 before using your pump. Section 6, the troubleshooting chart, should be used in conjunction with the rest of the manual should the need occur.

### 1-1 MANUAL KEY

This manual covers the following pump models (see Section 1-2) in addition to extreme-corrosive service pumps.

| Standard Series                                   | Corrosive Application Series                             | Dual-Speed Standard and Corrosive Application Series |
|---|--|--|
| D2A<br>D4A<br>D8A<br>D16A<br>D30A<br>D60A<br>D90A | D2AC<br>D4AC<br>D8AC<br>D16AC<br>D30AC<br>D60AC<br>D90AC | D60A2X<br>D60AC2X                                    |

"WARNING" statements are used in this manual to prevent injury to personnel; "CAUTION" statements are used to prevent damage to equipment. "NOTES" contain helpful information. "REQUIRED ACTION" is used where necessary to distinguish the action of the step from the WARNINGS, CAUTIONS, and NOTES.

Numbers in parentheses refer to position numbers of parts in the parts list (see Section 7). These numbers are also used to identify parts on the figures.

The terms "lubricating fluid," "pump fluid," "fluid," "oil," and "lubricant" when used in this manual refer to the "proper vacuum pump fluid."

### 1-2 MODEL AND CATALOG NUMBERS

To understand many of the instructions in this manual, you need to know the model number of your pump. The plate attached to the end of the pump (see Figure 1-1) lists the model, catalog, and serial numbers in addition to the catalog number of the standard oil for the pump.

Always supply us with the pump's serial and catalog numbers when returning it to one of our service centers. Also report the serial number of the pumping system where applicable.

TRIVAC<sup>®</sup>

MODEL NO. \_\_\_\_\_

CATALOG NO. \_\_\_\_\_

SERIAL NO. \_\_\_\_\_

THIS PUMP FILLED WITH \_\_\_\_\_

LEYBOLD VACUUM PRODUCTS INC.  
5700 Mellon Road Export, PA. 15632  
MADE IN U.S.A.

1TA-1

**Sketch 1-1. Identification Plate**

TRIVAC is a registered trademark of Leybold

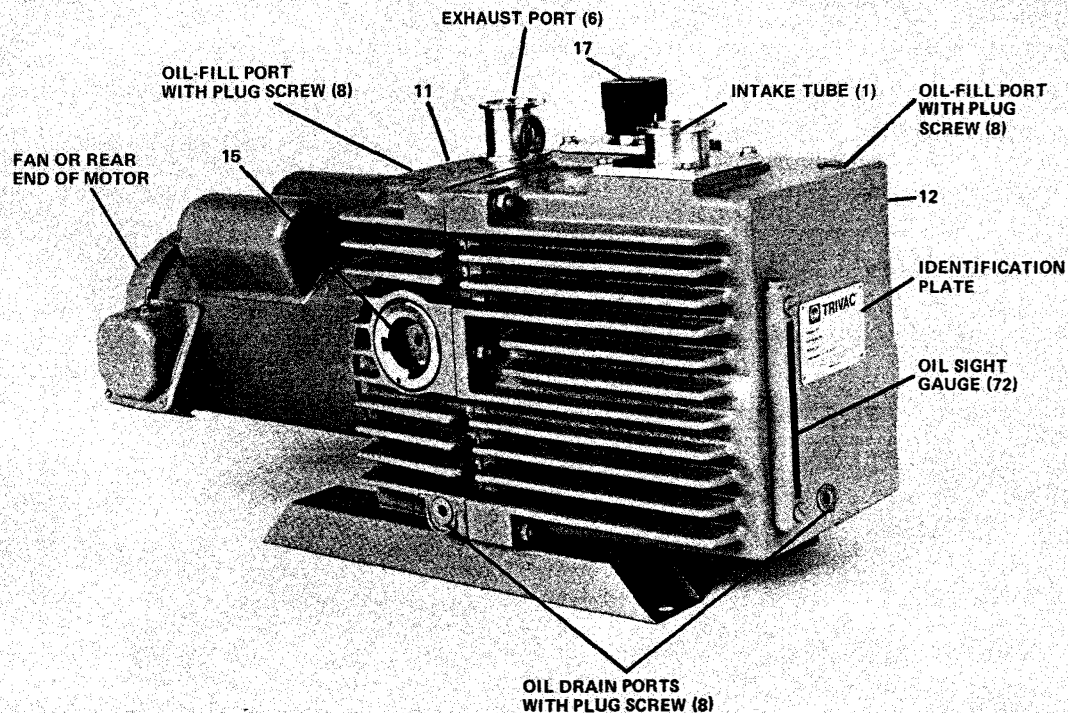

ITA-2.1

Figure 1-1. Location of the Identification Plate, the Oil Fill Ports and the Oil Drain Ports (D30A Pump Model Shown).

## SECTION 2

### PRINCIPLES OF OPERATION

Vacuum pumps are used to reduce the pressure in an enclosed vessel or system. For rough and medium vacuums ( $760$  to  $10^{-3}$  Torr), the intake tube (1) of the rotary vane pump is connected to the vessel to be evacuated. For high or ultrahigh vacuum ( $10^{-3}$  to  $10^{-11}$  Torr), the rotary vane pump is used as a backing or roughing pump and is connected in series and/or parallel with other types of pumps which are designed to obtain a high vacuum.

#### 2-1 DIRECT DRIVE MECHANISM

When the motor is switched on, the motor shaft turns the pump shaft. The motor shaft and pump shaft are connected directly through a coupling (37) and an elastic element (36) (see Figure 5-23). The elastic element (36) absorbs shock and vibration and results in quiet operation of the pump.

#### 2-2 PUMPING MECHANISM

##### 2-2-1 High Vacuum Stage Pump Cylinder

The pump intake tube (1) fits into the top of the high vacuum stage pump cylinder (55). The shaft and attached rotor (54) are mounted eccentrically in the high vacuum stage housing (52/60/55). Three rectangular vanes (53) fit into slots in the rotor (54) (see Figures 2-1 and 2-2).

As the shaft and rotor (54) rotate, centrifugal force pushes the vanes (53) out against the pump cylinder (55) inner surface (see Figure 2-2). The three vanes divide the cylinder into chambers  $120^\circ$  apart.

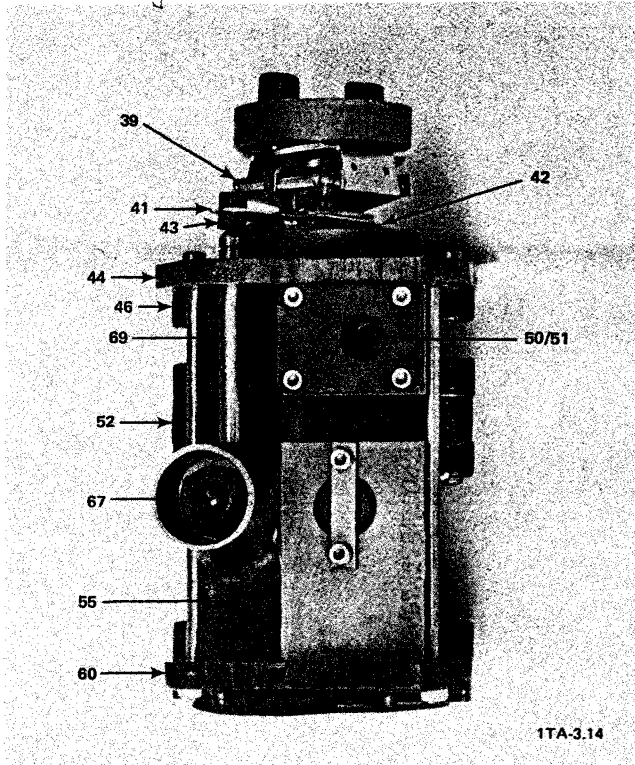

Figure 2-1. D4A Module

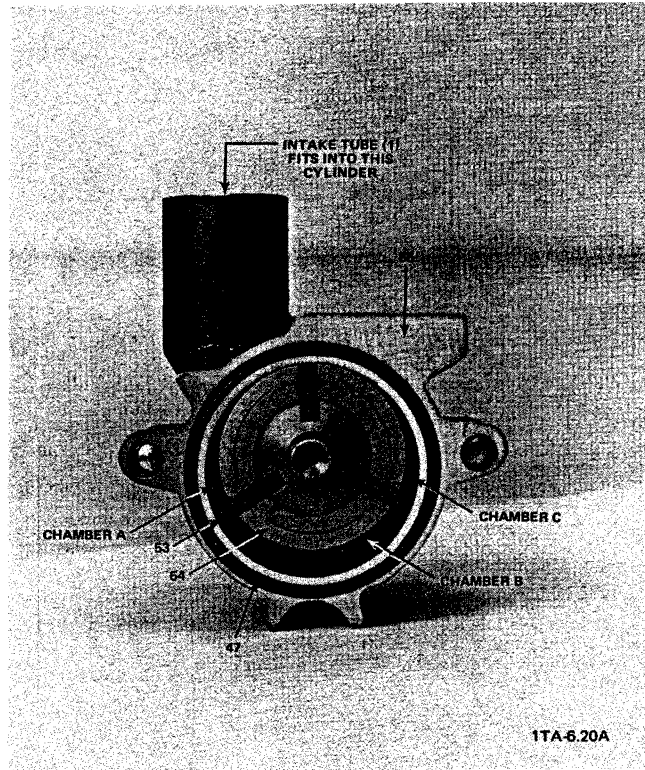

Figure 2-2. High Vacuum Stage Pump Cylinder With Rear End Plate Removed

One pumping cycle proceeds as follows (see Figure 2-2). Gas is drawn through the pump intake tube (1) into an increasingly large vacuum tight chamber (Chamber A). The rotation increases the size of the chamber until it is sealed off by a second vane (Chamber B). Further rotation diminishes the chamber size and compresses the gas (Chamber C). The gas is then forced out through an opening in the center bearing plate (52) and into the second stage pump cylinder (46) (see Figure 2-1).

With each cycle, the pump removes a portion of the original gas contained in the vessel or system being evacuated, until the ultimate pressure of the pump is reached.

The ultimate pressure is measured with the pump intake tube closed off. It is the lowest pressure attainable for a particular pump. The ultimate partial pressure for dual stage vane pumps is  $3 \times 10^{-4}$  Torr as measured with a  $LN_2$  cold-trapped ionization gauge. Ultimate pressure measured with thermocouple gauges will be approximately  $\frac{1}{2}$  to 1 decade higher.

### 2-2-2 Second Stage Pump Cylinder

The second stage of the pump is similar to the high vacuum stage in construction and operation. It accepts gas from the high vacuum stage, further compresses it, and then forces it out through the exhaust valve (50/51) (see Figures 2-1 and 2-3).

## 2-3 GAS BALLAST MECHANISM

### 2-3-1 Opening and Closing the Valve

There are two holes in the side of the gas ballast valve cap (18) on standard pump models. When one of these holes is aligned with the hole in the gas ballast valve (17), the valve is open (see Figure 2-3). When the side of the cap (18) is covering the hole in the gas ballast valve (17), the valve (17) is closed (see Figure 1-1).

To open the valve, turn the cap (18) until a cap hole is aligned with the valve (17) hole; to close the valve (17), turn the cap (18) so that the valve (17) hole is covered by the cap (18).

When the valve (17) is open, air at atmospheric pressure rushes in the cap-end hole, through the gas ballast valve stem and into the second stage pump cylinder (46) (see Figure 2-3).

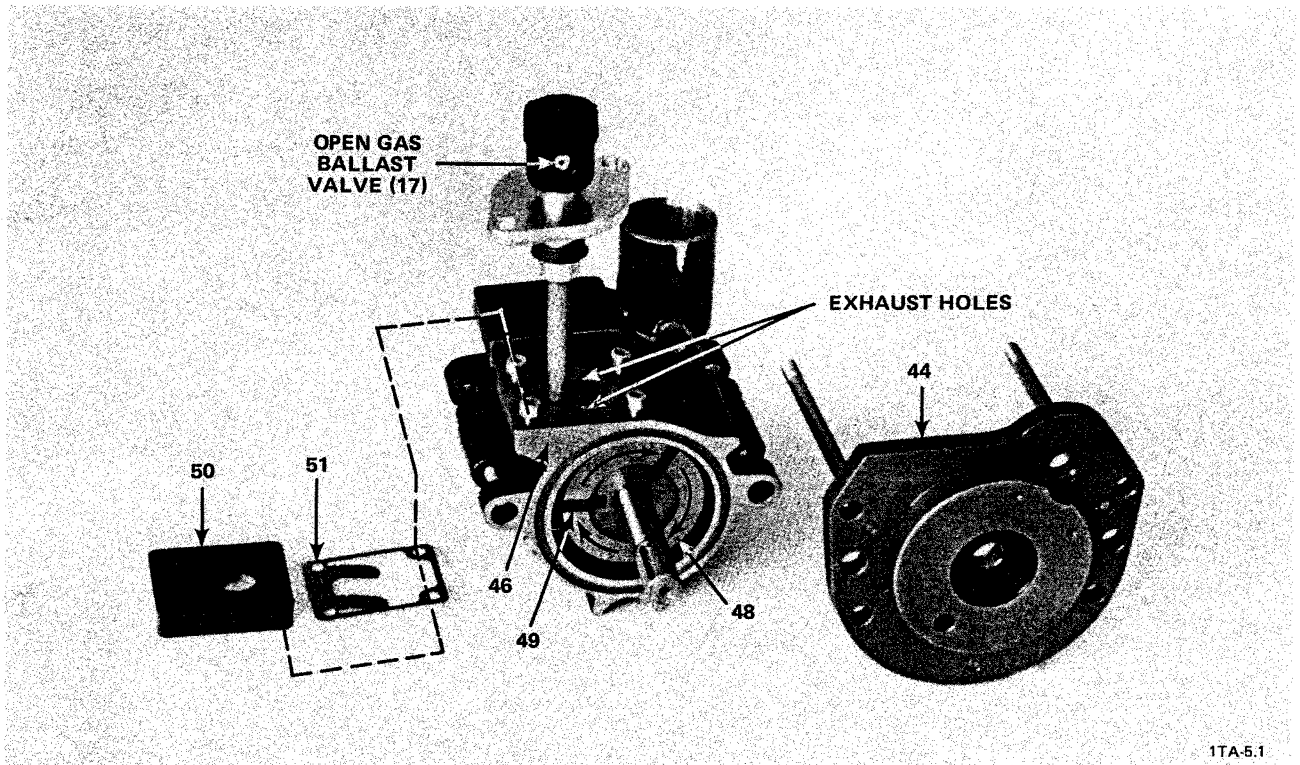

1TA-5.1

**NOTE:** This photograph is for illustration purposes only. When assembled, the cap end of the gas ballast valve (17) is attached outside the top of the oil casing (12) (see Figure 1-1), and an oil filter (35) and other parts fit around the valve (17) stem (see Figure 5-10B).

Figure 2-3. Gas Ballast Valve and Second Stage Pump Cylinder With Front End Plate Removed

### 2-3-2 Purpose and Function of the Gas Ballast Valve

All systems contain moisture. Some processes have large quantities of condensable vapors in the process gas. When these vapors condense in the pump, they degrade the lubricating and sealing qualities of the pump fluid (see Section 2-4) resulting in excessive pump wear, higher base pressure, and sometimes pump seizure.

The gas ballast valve allows removal of condensable vapors and condensate such as water, alcohol, gasoline, benzene, carbon tetrachloride, etc. from the pump. It also enables high levels of water vapors to be pumped without condensation. The water vapor tolerance for your pump is listed in Table 4-1. If the partial pressure of water vapor in the gas being pumped exceeds the tolerance of your pump, the vapor will condense. We recommend installing an AK condensate trap on the pump when pumping saturated vapors (see Section 1 of our catalog for more information on condensate traps).

When the gas ballast valve (17) is open, it admits a controlled amount of air into the second stage pump cylinder (46) just before the exhaust holes (see Figure 2-3). The open gas ballast valve prevents vapors from condensing by reducing the partial pressure of the condensable vapors and by increasing the operating temperature of the pump.

The gas ballast valve is not fully effective until the pump is warm to the touch. When using the gas ballast valve to remove condensate from the pump fluid, it is best to seal off the intake tube (1). Sealing off the intake tube (1) prevents additional vapors from entering the pump while the condensate is being vaporized and the vapor is being ejected. See Sections 4-1-2 and 4-2 for instructions for using the gas ballast valve during start-up and operation.

In addition to increasing the operating temperature, running the pump with the gas ballast valve open also results in higher ultimate pressure (see Table 4-1), higher pump fluid consumption, and a pump fluid mist in the exhaust stream. If you run the pump with the gas ballast valve open continuously, we recommend an SE smoke eliminator or an AF exhaust filter with an oil return line. After closing the gas ballast valve the pump normally reaches ultimate pressure as soon as it cools to operating temperature.



**NOTE:** On extreme-corrosive service pumps, the gas ballast valve (17) is sealed to prevent gases in the air from reacting with secondary gases or vapors in the pump. These pumps have a port on the valve (17) for installing a dry nitrogen gas line (see Sketch 2-1); the port is 1/8 inch NPT for the D2A and D4A models and 1/4 inch NPT for all other TRIVAC A models. The maximum nitrogen pressure is 2 psig delivered to the pump.

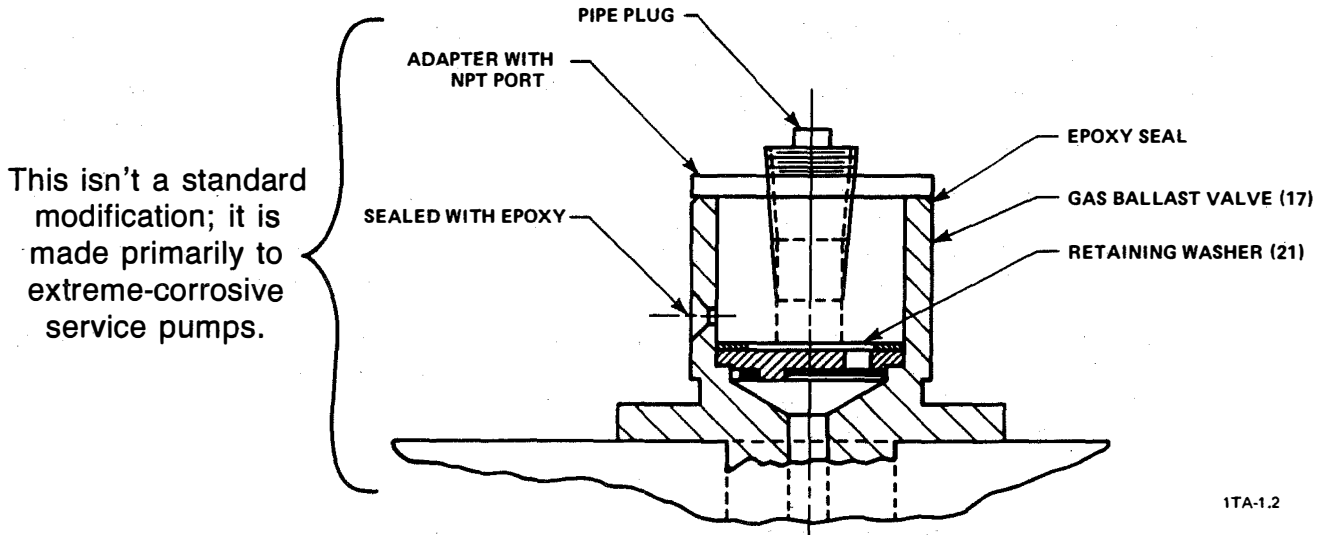

Sketch 2-1 Cross Section of the Gas Ballast Valve on the D8A/AC Extreme-Corrosive Service Pumps.

## 2-4 PUMP FLUID

The pump fluid partially fills the oil casing (12). It is injected from the oil casing (12) into the module through one or two oil nozzles (56) located in the second stage pump cylinder (46) (see Figure 5-8). Pump fluid consumption is minimal during normal operation, but increases when operating at high pressures or with the gas ballast valve open.

In addition to lubricating the moving parts, the pump fluid seals the clearances in the pumping module. This fluid seal is necessary for achieving the ultimate pressure of the pump. The pump fluid also transfers heat from the pumping element to the oil casing (12).

Other important qualities of the pump fluid include the following:

- It must have a low vapor pressure at the high temperature generated by gas compression and vane friction.
- It must be oxidation resistant.
- It must have a low water absorption rate.
- It must resist cracking under the mechanical stress of gas compression and vane pressure.

Based on operational testing, we have approved the following vacuum pump fluids for use in TRIVAC "A" pumps:

|                                |  |
|--------------------------------|--|
| Standard Applications          | HE-175 (hydrocarbon)                   |
| Corrosive Applications         | HE-200 or HE-400 (hydrocarbon)         |
| Extreme-Corrosive Applications | HE-1600 (perfluoropolyether)           |
| High-Temperature Applications  | HE-600 (synthetic diester hydrocarbon) |

If you use a nonapproved pump fluid, we can't guarantee that our pumps will meet their operating specifications (ultimate pressure, pumping speed, operating temperature, etc.). However, the warranty is voided only if the non-approved fluid adversely affects the operation or reliability of the pump. The pump's identification plate (see Page 3) indicates which pump fluid was initially used in the pump.

Section 2-3-2 mentions the detrimental effects of condensate on the pump fluid. Contaminants also destroy many of the essential qualities of the fluid, resulting in pump wear, slower pumping speed, higher ultimate pressure, and sometimes pump seizure. Change the pump fluid frequently to ensure good performance and to extend the life of your pump.

## 2-5 ANTI-SUCK BACK MECHANISM

When the pump is intentionally turned off or if there is a power failure, the anti-suck back mechanism seals the intake tube (1) and vents the pumping chamber. The pump starts easier when the pumping chamber is vented. The sealing of the intake tube (1) prevents pump fluid from surging back into the vacuum line and maintains the vacuum in the vessel or system.

The primary components of the anti-suck back mechanism are the centrifugal switch (39), the lever (41) with spring (42) and seal (43), the air inlet tube (69), and the piston (68) with valve disk (67) (see Figure 2-1).

The centrifugal switch (39) is attached to the shaft. When the pump is turned off, the shaft rotation slows, causing the centrifugal switch (39) to push against the lever (41). As a result, the lever (41) opens the air inlet tube (69) (see Figure 2-1). Air at atmospheric pressure rushes through the open tube (69) and into the high vacuum stage pump cylinder (55), thus venting the pump. This air also forces the brass piston (68) and attached valve disk (67) to seal the pump intake tube (1).

When the pump is started again, the shaft rotation causes the centrifugal switch (39) to pull away from the lever (41). A spring (42) pushes the lever in the opposite direction, causing the seal (43) attached to the lever to close the air inlet tube (69). The suction of the pump draws the valve disk (67) and attached piston (68) away from the opening in the intake tube (1) allowing the pump to further evacuate the vessel or system.

On AC pump models, the anti-suckback mechanism is modified to avoid exposing the pumping module to atmospheric air and to avoid the possibility of hazardous process gas escaping from the pump during shutdown. The centrifugal switch and lever assembly are removed and a solenoid valve with tubing is added so that the module is vented with gas from the oil casing during shutdown.

## SECTION 3

### PREPARING AND INSTALLING THE PUMP

#### 3-1 RECEIVING

**NOTE:** The Leybold packing list is attached to the outside of one of the shipping containers.

##### 3-1-1 Reporting Shipping Damage

Leybold makes every effort to ensure that your order is packed properly. However, rough or careless handling in transit occasionally results in shipping damage. In such cases, the carrier is responsible for the damages.

Unpack the pump and check for shipping damage as follows:

1. Inspect the outside of the shipping container for shipping damage. If you will be making a damage claim, save the shipping container and packing materials.
2. Unpack the pump.
3. Carefully inspect the pump for damage.
4. If you find any damage, proceed as follows:
  - a. Save the shipping container, packing material, and parts for inspection.
  - b. Notify the carrier that made the delivery within 15 days of delivery in accordance with Interstate Commerce regulations.
  - c. File a claim with the carrier.
  - d. Contact the Leybold Order Services Department to make arrangements for replacing the damaged part.

##### 3-1-2 Reporting Shipping Shortage

If you did not receive all the goods that you ordered, do the following:

1. Check the number of pieces listed in the upper right section of the packing list. If the number of pieces listed is greater than the number of shipping containers received, contact the carrier concerning the missing piece.
2. Check the packing list to see if the missing item is back ordered.
3. Carefully check the packing material and container to ensure that you did not overlook the missing item.
4. If you cannot find the item, contact our Order Services Department.

### 2-3 Reporting Incorrect Shipment

If the item received is not the item ordered, contact our Order Services Department.

### 3-2 INITIAL FILLING WITH PUMP FLUID

The larger pump models are shipped filled with pump fluid; the smaller pump models are shipped with the pump fluid in a separate container. Ensure that the oil is in the middle to upper third of the sight glass before starting the pump (see Figure 1-1).

### 3-3 CONNECTING THE PUMP TO THE SYSTEM

KF® clamp rings are supplied for the intake and exhaust ports of the pump. A centering ring with dirt trap (2) is supplied for the intake tube (1) and a centering ring with O-ring (7) is supplied for the exhaust port (6).

Leybold also has a complete line of components, fittings, and adapters to connect your pump to any system. See our catalog for a list of these components. See Table 4-1 for the intake and exhaust flange dimensions of your pump model.

All connections must be vacuum tight for your pump to achieve its ultimate pressure. The O-ring on the centering rings must be clean to avoid leaks.

Your pump will perform better and last longer if it is protected by the correct inlet filter and/or oil filtering system. See our catalog or contact your nearest sales office for the recommended filter for your application.

Any accessories, such as coaxial traps, dust separators, exhaust filters, or inlet filters should be connected after Step 2 below. Use the manual that comes with each accessory for installing, maintaining, and operating the accessory (see the Leybold catalog for additional information on accessories).

**CAUTION: IF YOU ARE PURGING THE GAS BALLAST VALVE, DO NOT EXCEED AN INERT GAS PRESSURE OF 2 psig; IF YOU ARE PURGING THE OIL CASE OR EXHAUST LINE WITH INERT GAS, DO NOT RAISE THE PRESSURE IN THE OIL CASING ABOVE 3 psig. EXCEEDING THESE PRESSURES WILL DEGRADE THE PUMP'S PERFORMANCE.**

Connect the pump to your system as follows:

1. Set the pump on a horizontal surface. It need not be permanently mounted on the surface (See Figure 1-1).

2. **CAUTION: FAILURE TO REMOVE THE SHIPPING WEDGE OR EXHAUST PORT COVER BEFORE STARTING THE PUMP COULD RESULT IN DAMAGE TO THE PUMP.**

Remove and discard the protective cover from the pump intake tube (1) and exhaust port (6) and the metal shipping disc from the exhaust port (see Figure 7-2, the foldout). Also remove and discard the red plastic shipping wedge from underneath the coupling housing (11). A Day-Glo orange tag attached to the pump contains instructions for removing the shipping wedge.

3. **CAUTION: ENSURE THAT THE VACUUM LINE IS CONNECTED TO THE INTAKE TUBE (1) AND NOT TO THE EXHAUST PORT (6) (see Figure 1-1). CONNECTING THE VACUUM LINE TO THE EXHAUST PORT (6) COULD RESULT IN DAMAGE TO THE PUMP OR TO YOUR SYSTEM.**

**NOTE:** Ideally, the inside diameter (ID) of the vacuum line should be the same size or larger than the ID of the intake tube (1). If the vacuum line is too narrow, it will reduce the pumping speed.

**REQUIRED ACTION:** Using the KF clamp ring and the centering ring with dirt trap (2) and O-ring (3), connect the pump intake tube (1) to the vacuum line.

®KF is a registered trademark of Leybold

**WARNING:** Don't install an exhaust line with a smaller ID than the exhaust port or have restrictions or closed valves in the exhaust line during operation. Such restrictions reduce the pumping speed and could damage the oil seals or cause a dangerous overpressure in the pump.

Using the KF clamp ring and the centering ring with an O-ring (7), make one of the following connections to the exhaust port (6).

- a. If practicable, install the exhaust line at a slightly descending angle to prevent condensate from flowing back into the pump and contaminating the pump fluid. Attach a drain valve at the lowest point in the exhaust line to drain off any condensates; then run the exhaust line up to its emission outlet. This arrangement also prevents particulates from dropping back into the pump from the exhaust line.
  - b. If the exhaust line must be installed in the ascending position and the process gas contains high levels of condensable vapors, connect an AK condensate trap to the exhaust port. AK traps serve to collect the condensates from saturated vapors. See Section 1 of our catalog for additional information on condensate traps.
  - c. If no exhaust line is connected and your pump will be running above 1 Torr inlet pressure, connect an AF or SE series exhaust filter to the exhaust port (6) to remove pump fluid vapors and smoke. See Section 1 of our catalog for additional information on exhaust filters.
5. If the exhaust line is attached to a negative pressure exhaust system, adjust the negative pressure so that pump fluid will not be drawn from the pump.

### 3-4 MAKING THE ELECTRICAL CONNECTION

When making the electrical connections for your motor, ensure that everything is grounded properly. Six-foot linecords are supplied on all standard single-phase 60-HZ motors that are purchased through Leybold. Most of our single-phase motors also have automatically resetting thermal overloads. If the motor doesn't have a linecord, you must provide the correct thermal overloads to protect the motor.

For 3-phase motors, use the schematic diagram on the motor nameplate or in the junction box to make the electrical connection.

For TRIVAC<sup>AC</sup> pump models with 3-phase motors, wire the solenoid valve for high or low voltage according to the instructions on the solenoid-valve nameplate. Attach the solenoid-valve leads to any two of the three input line voltage wires.

## SECTION 4 STARTING, OPERATING, AND MAINTAINING THE PUMP

### 4-1 START-UP

Before starting the pump, remove the shipping wedge; an orange cardboard tag on the pump has instructions for removing the wedge. The AC pump models don't have a wedge or a tag.

The motor manufacturer guarantees a maximum of six starts per hour at maximum power. To avoid exceeding six starts per hour, run the pump continuously and regulate the vacuum in your system with a valve.

#### 4-1-1 Check the Direction of Rotation

Refer to Section 5, Step F-1 to check the direction of motor rotation. Looking from the motor end of the pump, the motor fan should rotate clockwise. If the fan doesn't rotate in the correct direction, turn the pump off **immediately** to avoid damaging the motor or the pump.

#### 4-1-2 Using the Gas Ballast Valve During Pump Warm-up

**NOTE:** Opening the gas ballast valve (17) results in an oil mist in the exhaust stream and higher pump fluid consumption, operating temperature, and ultimate pressure. After closing the gas ballast valve, the pump normally reaches ultimate pressure as soon as it cools to operating temperature.

**CAUTION:** PUMPING PROCESS GAS WITH A COLD VANE PUMP CAN RESULT IN VAPORS CONDENSING IN THE PUMP FLUID.

1. Operate the pump with the gas ballast valve (17) open (see Section 2-3-1) and the intake tube (1) closed for about ½ hour while the pump is warming to operating temperature.

**NOTE:** If your system has a valve in the vacuum line, the intake tube (1) can be closed by shutting the vacuum-line valve during the pump warming period.

**NOTE:** When the pump is cold, condensation may occur in spite of the gas ballast valve being open.

2. Open the intake tube (1) and/or vacuum-line valve and allow the pump to operate for a few additional minutes with the gas ballast valve (17) open. This will remove condensable vapors from the system.

3. **NOTE:** Most of the vapors have been expelled from the pump when the pressure nears the "ultimate total pressure with gas ballast" (see Table 4-1).

**NOTE:** If your process has high levels of condensable vapors, it may be necessary to run the vane pump with the gas ballast valve open (see Section 2-3-2). When running continuously with the gas ballast valve open, we recommend installing an SE smoke eliminator or an AF exhaust filter with a return line.

Close (see Section 2-3-1) the gas ballast valve (17) after all vapors have been pumped out of the system or when there is only a small accumulation of vapor with a large excess of permanent gases.

## 4-2 OPERATION

**WARNING:** Don't pump toxic, pyrophoric, or hazardous gases unless your pump has the anti-suckback solenoid valve modification (see Pages 8 and 57). When pumping these hazardous gases, we recommend a negative pressure exhaust system and inert gas purging of the oil casing and gas ballast valve. In addition, a pump specially prepared for perfluoropolyether vacuum oil is required for pumping highly reactive or extremely corrosive gas. Contact the factory for recommendations.

**CAUTION:** Pumping corrosive gases with a standard pump can result in premature failure. Contact the factory for pump modifications for your particular process.

**CAUTION:** RUNNING THE PUMP AT GREATER THAN 1 TORR INLET PRESSURE RESULTS IN AN OIL MIST IN THE EXHAUST STREAM. INSTALL AN EXHAUST FILTER (SEE SECTION 3-3) AND CHECK THE PUMP FLUID LEVEL FREQUENTLY (SEE SECTION 4-3-1) WHEN OPERATING THE PUMP ABOVE 1 TORR

**CAUTION:** DO NOT RUN THE PUMP CONTINUOUSLY AT GREATER THAN 300 TORR INLET PRESSURE FOR THE D2A, D8A, AND D30A PUMP MODELS OR GREATER THAN 187 TORR FOR THE D4A, D16A, D60A, AND D90A PUMP MODELS.

The 115/230 V, 50/60 Hz, single-phase motors have an automatically resetting thermal overload. If this overload shuts off the pump and the ON/OFF switch is left ON, the motor will restart itself as soon as it cools down.

Table 4-1 lists operating and other technical data for each of the TRIVAC dual-stage vane pump models.

1. **NOTE:** The pump fluid is usually saturated with condensate when the fluid becomes milky white or dark and the pump runs hot and fails to reach its ultimate pressure (see Table 4-1).

**REQUIRED ACTION:** If during operation, the pump fluid becomes saturated with condensate, run the pump with the intake tube (1) and/or vacuum-line valve closed and the gas ballast valve (17) open (See Section 2-3-1) until the condensate is vaporized and expelled from the exhaust port (6).

2. If condensate in the pump fluid is severe, the pump should be flushed out and the pump fluid changed (see Section 4-3-2). See Symptom 1 of the Troubleshooting Chart (Table 6-1) for other methods of removing condensate from the pump fluid.

## 4-3 PREVENTATIVE MAINTENANCE

**NOTE:** See Section 6 (Troubleshooting) to resolve corrective maintenance problems.

### 4-3-1 Checking the Pump Fluid Level

**NOTE:** When the pump is not running, the pump fluid level appears lower.

**NOTE:** It is not unusual for the pump fluid to foam because of the churning action of the disk (oil slinger). Foaming is more pronounced at high operating pressures. If only foam is visible in the oil level glass (15), it means that the pump fluid level is low.

Occasionally check the pump fluid level when the pump is running near its ultimate pressure (see Table 4-1) and the gas ballast valve (17) is closed.

The minimum pump fluid level is reached when the fluid surface is visible at the lower rim of the oil level glass (15) or at the "L" mark on the oil sight gauge (72) (See Figure 1-1). If the pump fluid level is low, use Section 4-3-2, Steps 7, 8, and 9 to add the appropriate amount of the correct fluid.

The maximum pump fluid level is reached when the fluid surface is at the top rim of the oil level glass (15) or at the "H" mark on the oil sight gauge (72). If the pump fluid level is too high, use Section 4-3-2, Steps 1, 3, and 5 to drain **some** fluid. Recheck the oil level while the pump is running to ensure that the fluid level is correct.



TABLE 4-1. TECHNICAL DATA

| Pump Model  | D2A                | D4A                | D8A                | D16A               | D30A               | D60A               | D90A               |
|---|--------------------|--------------------|--------------------|--------------------|--------------------|--------------------|--------------------|
| Displacement . . . . CFM  | 2.2                | 4.5                | 7.0                | 14.1               | 26.8               | 36.7               | 53.7               |
| Displacement . . . . liters/minute  | 62.5               | 127                | 190                | 400                | 760                | 1030               | 1520               |
| Ultimate partial pressure† . . . . Torr   | $3 \times 10^{-4}$ | $3 \times 10^{-4}$ | $3 \times 10^{-4}$ | $3 \times 10^{-4}$ | $3 \times 10^{-4}$ | $3 \times 10^{-4}$ | $3 \times 10^{-4}$ |
| Ultimate pressure with gas ballast† . . . . Torr                                  | $3 \times 10^{-3}$ | $3 \times 10^{-3}$ | $3 \times 10^{-3}$ | $3 \times 10^{-3}$ | $3 \times 10^{-3}$ | $5 \times 10^{-3}$ | $5 \times 10^{-3}$ |
| Water vapor tolerance . . . . Torr  | 30                 | 15                 | 30                 | 15                 | 40                 | 20                 | 20                 |
| Oil Capacity . . . . . quarts (hydrocarbon)<br>. . . . . lbs (perfluoropolyether) | 0.5<br>2.5         | 0.75<br>3          | 1<br>4.2           | 1.25<br>5          | 3.5<br>13.7        | 4<br>16.8          | 4<br>16.8          |
| Motor power . . . . hp  | 1/3                | 1/3                | 1                  | 1                  | 1-1/2              | 2.0                | 3.0                |
| Pump rotational speed . . . . RPM   | 1725               | 1725               | 1725               | 1725               | 1725               | 1150               | 1725               |
| Weight complete . . . . lb  | 41                 | 45                 | 80                 | 85                 | 163                | 210                | 210                |
| Sound pressure level (max) at three feet with<br>gas ballast closed . . . . dB(A) | 50                 | 50                 | 60                 | 62                 | 59                 | 60                 | 60                 |
| Sound pressure level (ave) at three feet with<br>gas ballast open . . . . dB(A)   | 54                 | 56                 | 57                 | 60                 | 62                 | 63                 | 63                 |
| Intake tube and exhaust port diameter . . . . mm                                  | KF *16             | KF *16             | KF *25             | KF *25             | KF *40             | KF *40             | KF *40             |
| Maximum ambient temperature   | 104°F (40°C)       |                    |                    |                    |                    |                    |                    |

† The ultimate pressure<sup>+</sup> of pumps filled with perfluoropolyether fluid is  $9 \times 10^{-4}$  Torr except for 50-Hz D60A pump models. The ultimate pressure of D60A pumps with perfluoropolyether fluid and with 50-Hz motors is  $3 \times 10^{-3}$  Torr.

+ The "ultimate partial pressure" is measured with an LN<sub>2</sub> trapped ionization gauge. The "ultimate pressure with gas ballast" is measured with a Kammerer Type McLeod Compression Gauge. Both of these pressures can be as much as a decade higher when measured with a thermal conductivity gauge.

\* KF – Leybold quick assembly clamp ring diameter.

#### 4-3-2 Changing the Pump Fluid

**WARNING:** IF THE PUMP HAS BEEN USED ON CORROSIVE, TOXIC, OR VOLATILE CHEMICALS, OBSERVE PROPER SAFETY PRECAUTIONS BEFORE REMOVING THE PLUG SCREW (8).

**CAUTION:** HYDROCARBON PUMP FLUID SHOULD BE CHANGED AT THE FOLLOWING TIMES: (a) AFTER A 100-HOUR BREAK-IN PERIOD OF PUMP OPERATION, (b) WHEN THE PUMP FLUID IS CONTAMINATED (see Section 4-3-3), (c) WHEN CONDENSATION IN THE PUMP FLUID IS SEVERE (see Section 4-2), AND (d) BEFORE AND AFTER THE PUMP IS STORED FOR A LENGTHY PERIOD (see Section 4-3-4). PERFLUOROPOLYETHER FLUID SHOULD BE RECONDITIONED WHEN IT BECOMES CONTAMINATED.

**NOTE:** Always change the pump fluid while the pump is warm to prevent condensables from remaining in the pump.

Turn the pump off and change the fluid as follows:

1. **Ensure that the pump is turned off;** then place an appropriate container under one of the oil drain ports to catch the used pump fluid.
2. If a negative pressure exhaust system is attached to the exhaust line of the pump, disconnect it.

**NOTE:** A negative exhaust pressure prevents the pump fluid from draining completely.

3. **SEE THE SECTION 4-3-2 WARNING-**Using an 8 mm allen wrench, unscrew and remove the plug screw (8) from one of the oil drain ports and allow the fluid to drain from the pump (See Figure 1-1).
4. When the flow of fluid slows, briefly switch the pump ON and OFF to drain the remaining fluid.
5. Using an 8-mm allen wrench, reinstall the plug screw (8) with flat gasket (9) into the oil drain port.

- 6. If the used pump fluid is very dirty, flush out the pump as follows:
  - a. If not already done, **turn off the pump** and refer to Steps 1 through 5 to drain the used pump fluid.
  - b. **CAUTION:** WHEN FLUSHING OUT THE PUMP, FILL IT TO **CAPACITY** WITH PUMP FLUID. SEE TABLE 4-1 FOR THE FLUID CAPACITY OF YOUR PUMP MODEL.  
  
Disconnect your vacuum line from the intake tube (1), turn the pump on, and **slowly** pour clean pump fluid into the intake tube (1) while the pump is running.
  - c. Allow the pump to run for at least 10 minutes, then turn it off.
  - d. Repeat Steps 1, 3, 4, and 5 to drain the fluid from the pump.
  - e. If the pump fluid used for flushing is dirty, repeat Steps 6b through 6e.
  - f. Reconnect the vacuum line to the intake tube (1).
- 7. **SEE THE SECTION 4-3-2 WARNING-**Unscrew and remove the plug screw (8) from one of the oil fill ports (See Figure 1-1).
- 8. **NOTE:** The fluid capacity of each dual stage TRIVAC pump model is listed in Table 4-1. The correct pump fluid is listed in Section 5-A-1.  
  
Pour the pump fluid into the oil fill port.
- 9. Using an 8-mm allen wrench, reinstall the plug screw (8) with flat gasket (9) into the oil fill port.
- 10. If the negative pressure exhaust system was disconnected in Step 2, reconnect it.

**4-3-3 Checking the Pump Fluid for Contamination**

Occasionally check the pump fluid for contamination by looking through the oil level glass (15) on the side of the pump. If the fluid in the oil-level glass (15) has an unusual color, is very dark, or appears dirty or turbid, refer to Section 4-3-2 to change the fluid. For anti-corrosive fluid, flakes in the fluid indicate that its corrosive resistance is spent and thus the fluid should be changed. The oil-sight tube (72) on the end of the oil casing does not give an accurate indication of the condition of the pump fluid (see Figure 5-1).

**NOTE:** See Section 4-2 for identifying and eliminating condensate from the pump fluid.

**NOTE:** See Symptom 2 of the Troubleshooting chart (Table 6-1) for other methods of eliminating contamination from the pump fluid.

**NOTE:**The frequency of pump fluid change can vary from several months to every day depending on the operating conditions of the pump. The frequency must be adjusted to the operating conditions. If the pump fluid becomes contaminated quickly, use an OF-3000 or OF-1000 Oil Filtering System to protect the pump and to extend the period between pump fluid changes.

**4-3-4 Long Term Storage (2 weeks or longer)**

Use the Section 4-3-2 instructions to flush out the pump and change the pump fluid before and after the pump is stored for a lengthy period. After changing the fluid, run the pump for about 20 minutes with the intake sealed off and the gas ballast valve open (see Section 2-3) to ensure that all the internal parts are coated with clean pump fluid. Cover the intake and exhaust of the pump to prevent dirt, dust, and condensation from entering during storage.

**4-3-5 Checking the Dirt Trap**

Occasionally check the wire mesh dirt trap (2) that rests on the pump intake tube (1). A buildup of contaminants on the dirt trap reduces the pumping speed.

**4-3-6 Avoiding Oil Leaks During Shipping and Storage**

Tightly sealing the pump's inlet and exhaust ports for shipping or storage can cause oil leaks. To avoid oil leaks during shipping and storage, use a flexible membrane or a rigid cover with a pin hole on the pump's inlet and exhaust ports. The flexible membrane or pin hole accommodate the pressure differences that occur during air shipments and during temperature changes.

As further precautions against oil leaks during shipping, we insert a wedge up under the coupling housing to hold the anti-suckback lever and seal in the closed position. We also drain the oil from the smaller pumps in case they are turned upside down.

## SECTION 5

## DISASSEMBLY, CLEANING, AND ASSEMBLY INSTRUCTIONS

Section 5 is a detailed step-by-step procedure for disassembling, cleaning, and assembling the TRIVAC dual-stage vane pumps. It is to be used in conjunction with the troubleshooting chart (Table 6-1) for pump repair.

**MODULE REPLACEMENT PROCEDURE**

**NOTE:** The correct replacement module for your pump is listed in the parts list (see Section 7).

**NOTE:** If your pump has the anti-suckback solenoid valve modification, see the supplement (P/N 722-78-031) that came with the pump for special instructions on replacing the pumping module.

If you prefer to replace the \*module rather than repair it, proceed as follows:

1. Use the Section 5-B instructions for disassembly.
2. Do Steps F-12, F-13, and F-14 (except B-8).
3. Add the proper pump fluid (see Section 5-A-1) as follows (see Figure 1-1).
  - a. Using an 8-mm allen wrench, screw a plug screw (8) with flat gasket (9) into each oil drain port.
  - b. Pour pump fluid into the exhaust port (6) or an oil fill port until the fluid level is halfway up the oil level glass (15) or oil sight gauge (72).
  - c. **NOTE:** The pump may run noisily until the pump fluid has time to flow into the module. Run the pump for ½ to 1 minute and then turn it off.
  - d. Add additional pump fluid as necessary to bring the pump fluid level halfway up the oil level glass (15) or between the L and the H marks on the oil sight gauge (72).
  - e. Using an 8-mm allen wrench, screw a plug screw (8) with flat gasket (9) into each oil fill port.
4. Do Steps F-16 and F-17.

**5-A REQUIRED MATERIALS AND TOOLS****5-A-1 Required Materials**

**CAUTION:** DO NOT DISASSEMBLE THE \*MODULE UNLESS YOU HAVE THE CORRECT MODULE REPAIR KIT OR GASKET SET. The repair kit contains a gasket set, a valve plate (50), and vanes (49/53). The kit for the D2A, D4A, D8A, and D16A pump models also contains an oil filter (35). The catalog number for a gasket set or repair kit for each dual-stage pump model is listed in the parts list (See Table 7-1).

Correct gasket set or module repair kit  
Container for catching pump fluid

Standard cleaning solvent such as acetone  
Do **not** use a hydrocarbon solvent if your pump will be filled with any PFPE pump fluid†.

Grade 400 sandpaper

Correct pump fluid† as follows:

**CAUTION:** UNDER CERTAIN CIRCUMSTANCES, THE PUMP FLUID RECOMMENDED BY THE FACTORY MAY BE DIFFERENT THAN THAT LISTED BELOW. IN THESE INSTANCES, USE THE FACTORY RECOMMENDED FLUID.

| Pump Application              | Pump Fluid†      |
|-------------------------------|------------------|
| Standard Series               | HE-175           |
| Extreme-Corrosive Service     | HE-1600 (PFPE)   |
| Corrosive Application Series  | HE-200 or HE-400 |
| High-Temperature Applications | HE-600           |

Replacement parts as needed (see Section 7 for parts list).

**5-A-2 Required Tools**

**NOTE:** All required tools and all nuts, bolts, screws, and threaded holes are metric, except for the wrenches required for the U. S. standard bolts or screws securing the motor to the coupling housing adapter flange (72) and the screws and bolts used in the motor.

\*The module is the unit made up primarily of the shaft, rotors, vanes, coupling, centrifugal switch, end plates, pump cylinders, and center bearing. Figure 5-3 shows a module.

†The terms "lubricating fluid," "pump fluid," "fluid," and "lubricant" when used in this manual refer to the "proper vacuum pump fluid". The pump's identification plate lists the type of vacuum pump fluid that we initially added to the pump when it was new.

**WARNING: ALL TOOLS MUST BE DEGREASED BEFORE USE ON PUMPS FILLED WITH PERFLUORO-POLYETHER FLUID.**

Metric allen wrench set  
 Medium screwdriver  
 Phillips head screwdriver  
 Small screwdriver  
 Small diagonal cutting pliers  
 Snap ring pliers  
 Hammer  
 Drift pin or long brass bolt  
 Metric box or ratchet wrench set  
 Rubber hammer or lead or brass faced hammer  
 Long nose pliers  
 Puller (optional)  
 Thin wooden block to be used as fulcrum  
 For D30A, D60A, and D90A pump models: U. S. standard allen and socket wrench set  
 For all other pump models: U. S. standard box or open-end wrench set  
 Adjustable spanner; or large pair of snap ring pliers or two drill bits, drift pins, or other sturdy pins  
 Cleaning brush  
 Vernier calipers or micrometers  
 Paint brush  
 Shaft sleeve or cellophane tape  
 Seal driver (optional)

## **5-B REMOVING THE MODULE FROM THE PUMP**

**WARNING: IF THE PUMP HAS BEEN USED ON CORROSIVE OR VOLATILE CHEMICALS, OBSERVE PROPER SAFETY PRECAUTIONS TO PROTECT PERSONNEL BEFORE OPENING THE PUMP.**

**WARNING: DO NOT BEGIN DISASSEMBLING THE PUMP UNTIL THE MOTOR SWITCH IS TURNED TO THE "OFF" POSITION AND THE POWER IS DISCONNECTED.**

**NOTE:** While disassembling the pump, note the location of the O-rings, gaskets, and seals so that the new parts can be placed in the correct locations during reassembly.

- B-1** Remove the KF clamp ring from the intake tube (1) and exhaust port (6) to disconnect the pump from your system.
- B-2** Remove the dirt trap with O-ring (2 and 3) from the intake tube (1) and the centering ring (7) from the exhaust port (6).
- B-3** Using an 8-mm allen wrench, remove the oil-fill and oil-drain plug screws (8) and flat gaskets (9) and allow the lubricating fluid to drain from the pump into a proper container (see Figure 5-1).
- B-4** Remove the intake tube (1) from the oil casing (12) as follows:
- Unscrew and remove the screws and washers that attach the intake tube to the oil casing (see Figure 5-1).
  - CAUTION: WHEN USING A SCREWDRIVER, USE CARE TO AVOID NICKING OR SCRAPING THE ALUMINUM CASING. A NICK OR SCRATCH MAY CAUSE AN EXHAUST GAS LEAK OR A LUBRICATING FLUID LEAK.**  
 Pull the intake tube (1) up from the oil casing (12). If additional force is required, move the intake tube (1) from side-to-side or use a screwdriver to pry the tube from the casing.
  - Using care to avoid nicking or scraping the casing or flange, clean the used flat gasket (4) from the oil casing and/or intake tube flange.
- B-5** Repeat Steps B-4a through B-4c, except this time remove the gas ballast valve assembly (17) from the oil casing (12).
- B-6** Remove the oil filter (35) from the gas ballast hole in the oil casing (12) (see Figure 5-10B).

**NOTE:** For the D30A, D60A, and D90A pump models, the oil separator (35) may cling to the gas ballast valve when the valve is removed in Step B-5. In this case, pull the oil separator off of the gas ballast valve stem.

- B-7** **WARNING: PUMP FLUIDS ARE EXCELLENT LUBRICANTS AND AS SUCH ARE VERY SLIPPERY. BE CAREFUL WHEN HANDLING THE OIL CASING SINCE IT CONTAINS LUBRICATING FLUID WHICH COULD SPILL CAUSING A HAZARD.**

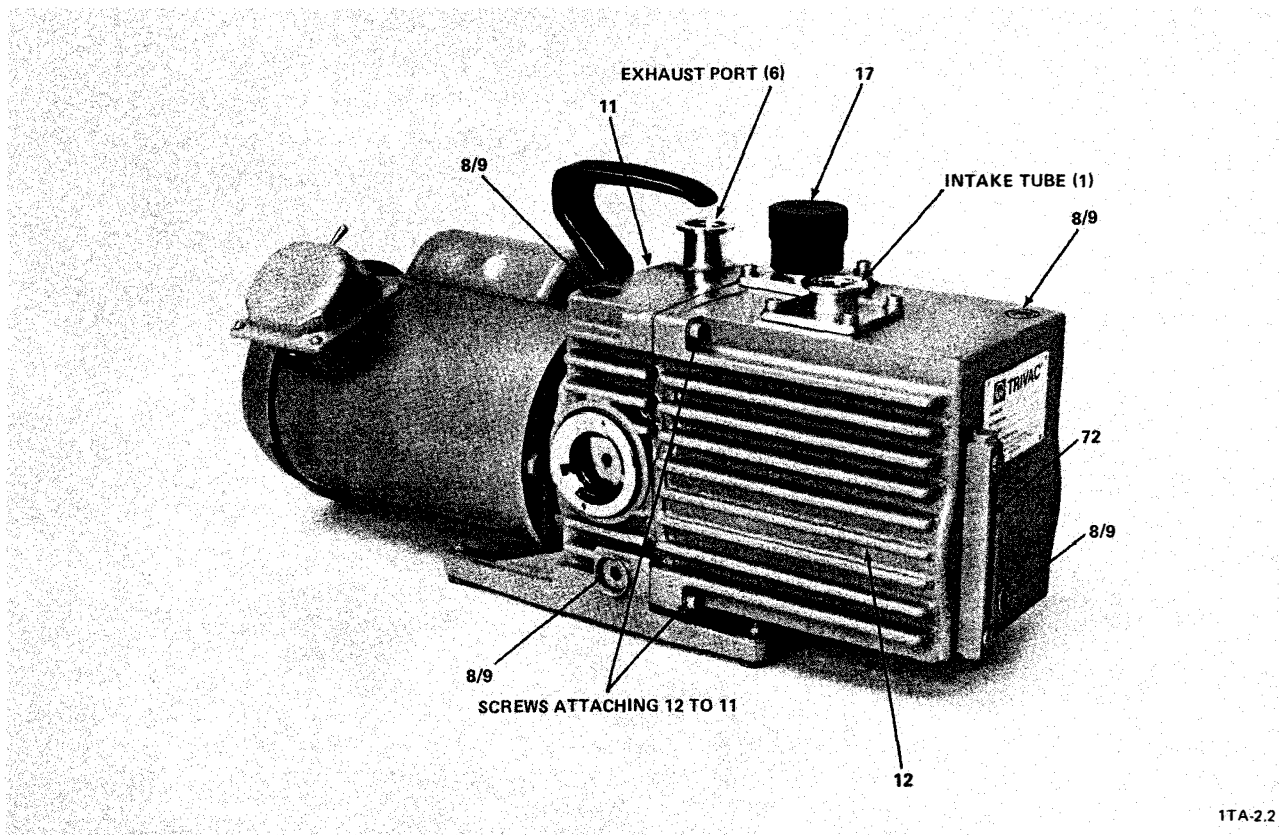

Figure 5-1. Assembled Pump (D16A Pump Model Shown)

Remove the oil casing (12) as follows:

- a. Unscrew and remove the lower screws (or nuts) and washers that attach the oil casing (12) to the coupling housing (11) (see Figure 5-1).
- b. **WARNING:** ESPECIALLY FOR THE HEAVIER PUMPS (D30A AND D60A), BE SURE TO SUPPORT THE OIL CASING WHILE REMOVING THE SCREWS (OR NUTS). OTHERWISE, THE CASING MAY FALL, RESULTING IN DAMAGE OR INJURY.

While supporting the oil casing, unscrew and remove the upper screws (or nuts) and washers.

- c. **NOTE:** If you plan to reuse the large flat seal (13) that fits between the oil casing and the coupling housing, carefully peel the seal (13) from the oil-casing flange before removing the oil casing (see Figure 5-2).

Remove the oil casing by sliding it straight back away from the main flange of the coupling housing.

**NOTE:** If resistance is encountered, strike the front corner of the oil casing (12) with a rubber hammer to release the oil casing (12) from the coupling housing (11).

- B-8 WARNING:** THE DISK ON THE MODULE END HAS A SHARP EDGE. FAILURE TO USE CARE WHEN REMOVING AND HANDLING THE DISK MAY RESULT IN INJURY.

Using a phillips head screwdriver, remove the disk (61) from the shaft (see Figure 5-2).

- B-9 WARNING:** PUMP FLUIDS ARE EXCELLENT LUBRICANTS AND AS SUCH ARE VERY SLIPPERY. BE CAREFUL WHEN HANDLING THE MODULE SINCE IT CONTAINS LUBRICATING FLUID WHICH COULD SPILL CAUSING A HAZARD.



**STEP B-9 CONTINUED**

Remove the module as follows:

- a. Unscrew and remove the lower screws and washers that attach the module to the coupling housing (11) (see Figure 5-2).
- b. **WARNING: ESPECIALLY FOR THE HEAVIER PUMPS (D30A AND D60A), BE SURE TO SUPPORT THE MODULE WHEN REMOVING THE SCREWS. OTHERWISE, THE MODULE MAY FALL RESULTING IN DAMAGE OR INJURY.**

While supporting the module, unscrew and remove the remaining upper screws and washers.

- c. Pull the module **straight back** and away from the coupling housing (11).

**B-10** Clean the large flat seal (13) from the coupling housing (11) and/or front end plate (44) (see Figure 5-2).

**NOTE:** A replacement gasket is supplied with the gasket set and module repair kit.

**5-C DISASSEMBLING THE MODULE**

**CAUTION:** USE CARE WHEN HANDLING THE MODULE TO AVOID BENDING THE LEVER (41) OR CENTRIFUGAL SWITCH (39) (see Figures 5-3 and 5-4).

- C-1 Using a large pair of long nose pliers, pull the valve disk (67) and attached brass piston (68) out of the intake portion of the high vacuum pump cylinder (55) (see Figures 5-3 and -11).

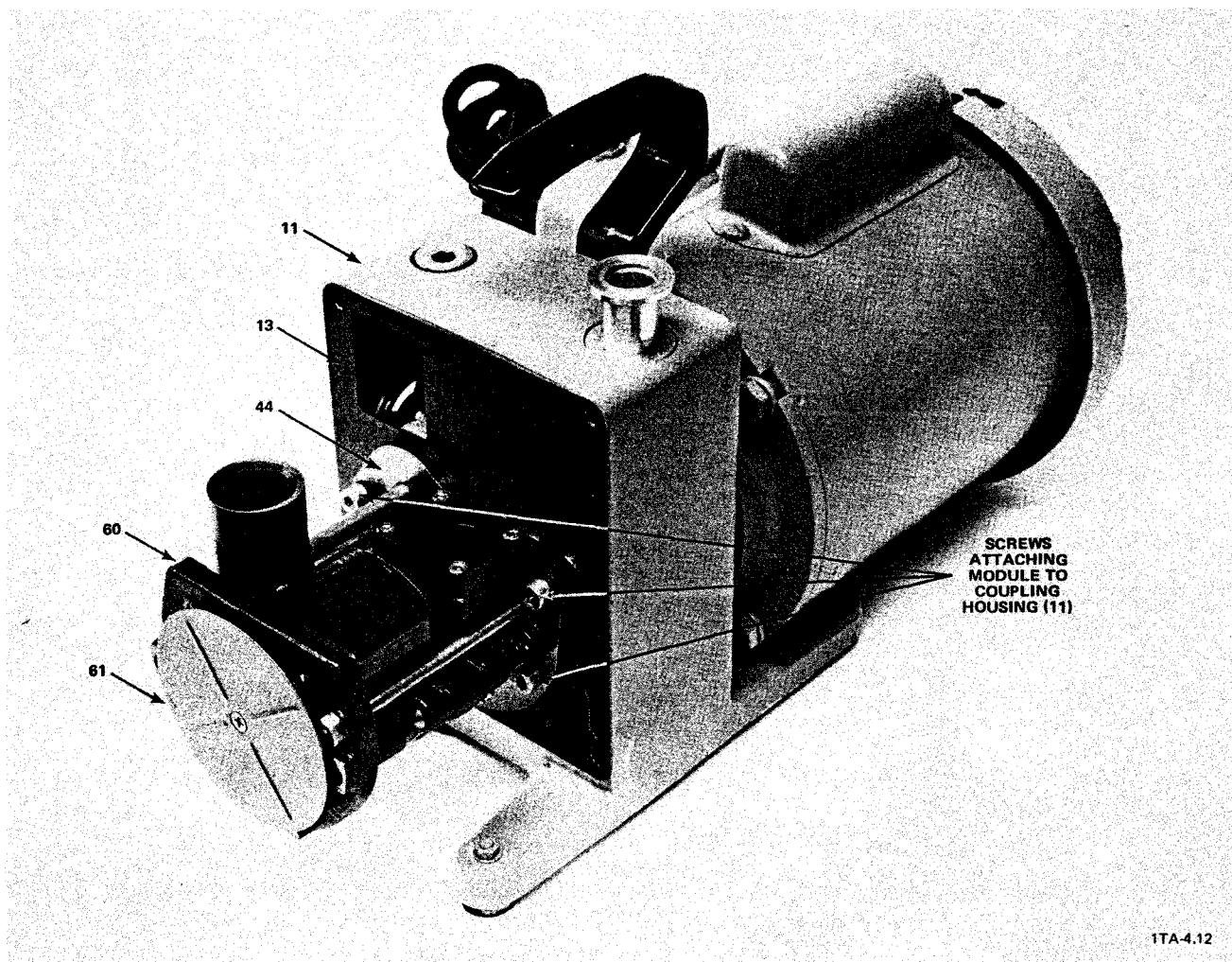

Figure 5-2. Module Attached to Coupling Housing (D2A Pump Model Shown)

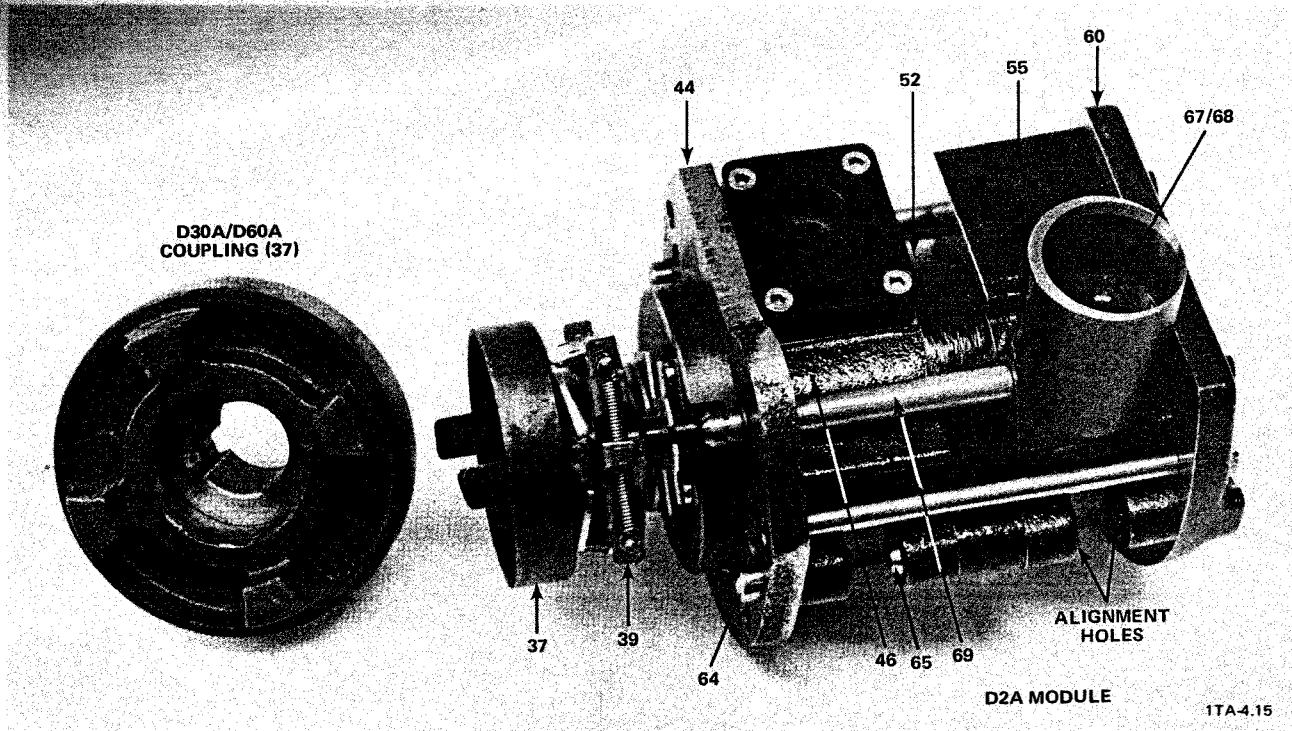

Figure 5-3. Module, Side View (D2A Pump Model Shown)

- C-2 CAUTION:** IF A PULLER IS USED TO REMOVE THE COUPLING (37), BE CAREFUL TO AVOID DAMAGING THE CENTRIFUGAL SWITCH (39).

Using a small screwdriver, loosen the setscrew that secures the coupling (37) to the shaft. Pull the coupling off of the shaft (see Figure 5-3).

- C-3** Using small diagonal cutting pliers, pull the coupling key (38) from the slot in the shaft (see Figure 5-4).

- C-4** Using snap ring pliers, remove the retainer ring (40) from the shaft (see Figure 5-4).

- C-5 NOTE:** For use during reassembly, the centrifugal switch end with the split halves faces the coupling (37).

**For the D2A, D4A, D8A, and D16A models only,** loosen the one or two setscrews that secure the centrifugal switch (39) to the coupling (37) (see Figure 5-3).

**For the D30A, D60A, and D90A pump models only,** loosen the setscrew(s) to remove the centrifugal switch (39) from the shaft rather than from the coupling (37).

- C-6** Using a phillips screwdriver, unscrew and remove the two screws that attach the lever to the front end plate. When removing the lever (41), hold its opposite end down to avoid losing the spring (42) from the penetration in the front end plate (44). Remove the lever (41) and spring (42) from the plate (44) (see Figure 5-4).

- C-7** Using a small screwdriver, remove the retainer disk (71) from the slot in the air inlet (69) tube (see Figure 5-4).

- C-8 CAUTION:** FAILURE TO HOLD THE DRIFT PIN (or bolt) STRAIGHT WHEN DRIVING THE CYLINDRICAL PINS COULD RESULT IN DAMAGE TO THE MODULE HOUSING.

Using a hammer and a drift pin (or long bolt), remove the cylindrical pins as follows (see Figure 5-5).

- a. Drive one of the two short cylindrical pins (64) that aligns the rear end plate (60) and the high vacuum stage pump cylinder (55) toward the center bearing (52) until the pin (64) falls out.

**NOTE:** On some pump models, this pin (64) does not have room to fall out. In this case, continue driving it until all three pins fall out of the alignment hole in the front end plate (44).

- b. While keeping the drift pin (or bolt) inserted through the rear-end-plate alignment hole, drive the long cylindrical pin (65) toward the front end plate (44). Continue driving the cylindrical pins

**STEP C-8b CONTINUED**

until the long pin (65) forces the other short pin (the one that aligns the front end plate (44) and the second stage pump cylinder) to fall out, and then the long pin also falls out of the front-end-plate alignment hole (see Figure 5-5).

- c. Repeat Steps C-8a and C-8b for the two short and one long cylindrical pins on the other side of the module.

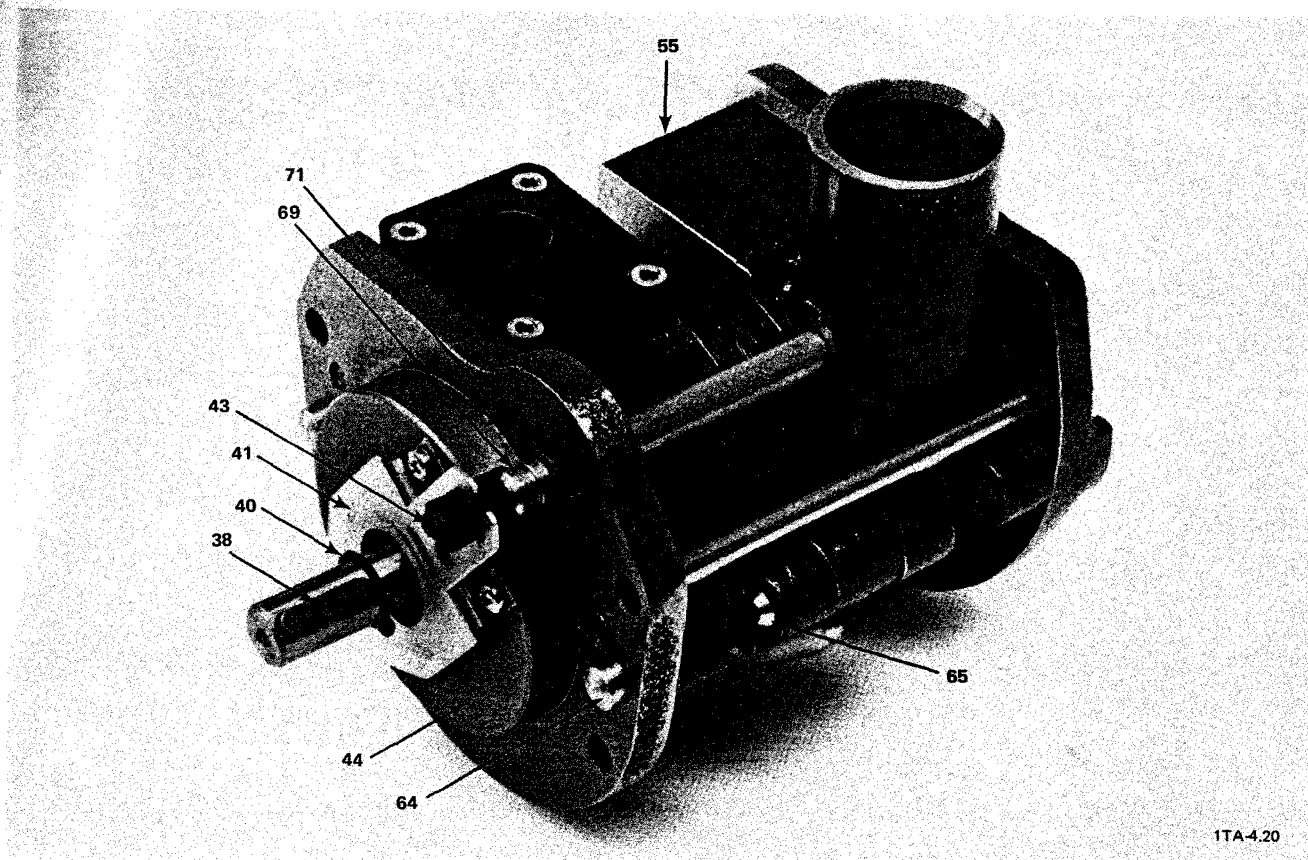

Figure 5-4. Front End of Module Minus Coupling and Centrifugal Switch (D2A Pump Model Shown)

- C-9** Unscrew and remove the hexagon nuts (63) and washers from the ends of the threaded studs (62) which tie the module segments together (see Figure 5-6).

**NOTE:** The D8A and D16A pump models have four, rather than three, threaded studs and hexagon nuts.

- C-10** Remove the rear end plate (60) from the module (see Figure 5-6).

**NOTE:** If necessary, lightly tap the back edge of the plate with a rubber hammer to free the plate from the module. This note also applies to Steps C-12, C-13, and C-15.

- C-11 CAUTION:** DO NOT SCRATCH THE INSIDE SURFACE OF THE PUMP CYLINDER OR THE END OF THE ROTOR. SCRATCHES ON THESE SURFACES RESULT IN POOR ULTIMATE PRESSURE.

**CAUTION:** DO NOT CHIP, SCRATCH, OR BREAK THE EDGES OF THE VANES DURING DISASSEMBLY, IF THEY ARE TO BE REUSED.

**NOTE:** If you plan to reuse the vanes, be sure to mark the orientation and location of each vane so that during reassembly each used vane is replaced in its same rotor slot and so that each used vane is **not** turned end-for-end in its slot.

**REQUIRED ACTION:** Using long nose pliers, remove the three vanes (53) from the high vacuum rotor (54). (See Figure 5-7).

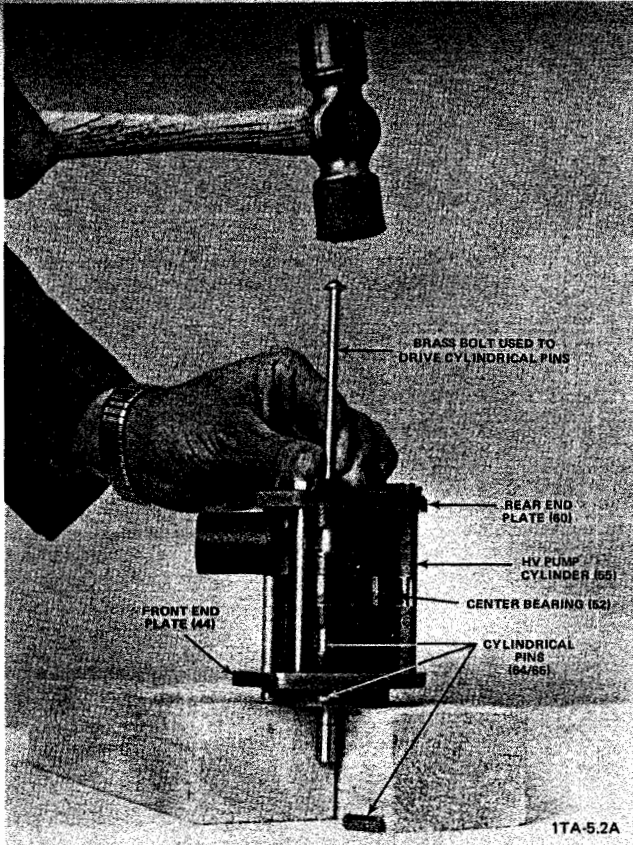

Figure 5-5. Removing the Cylindrical Pins From the Module (D2A Pump Model Shown)

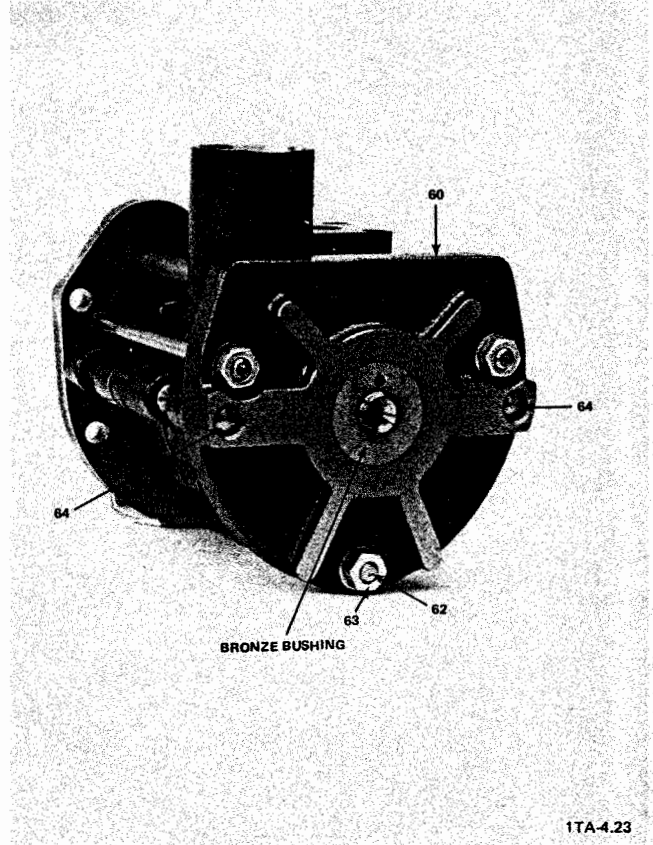

Figure 5-6. Rear End of Module Minus the Disk (D2A Pump Model Shown)

- C-12 Remove the high vacuum stage pump cylinder (55) to expose the high vacuum rotor (54) and the center bearing (52). Remove the O-rings (47) from both sides of this pump cylinder (see Figure 5-7).
- C-13 Remove the front end plate (44) from the motor side of the shaft (see Figure 5-8).
- C-14 Pull the air inlet tube (69) from the front end plate (44) or high vacuum stage pump cylinder (55). (See Figures 5-3 and 5-8.)
- C-15 Remove the second stage pump cylinder (46) to expose the second stage rotor (48). Remove the O-rings (47) from both sides of this cylinder (see Figure 5-8).
- C-16 Repeat Step C-11, except remove the vanes (49) from the second stage rotor (48). (See Figure 5-8).
- C-17 **CAUTION:** BE CAREFUL TO AVOID SCRATCHING THE END OF THE ROTOR OR THE CENTER BEARING. SCRATCHES TO THESE SURFACES RESULT IN POOR PUMP PERFORMANCE.  
**REQUIRED ACTION:** Using a puller or a prying device, remove the high vacuum stage rotor (54) from the shaft.  
**NOTE:** Two threaded metric pulling holes are located in the outside end of the high vacuum rotor (54) for use with a puller (see Figure 5-7).  
**NOTE:** The second stage rotor (48) and the shaft are permanently attached to each other on the D2A, D4A, D8A, and D16A pump models.
- C-18 Using small diagonal cutting pliers, pull the high-vacuum-stage rotor key (57) from the slot in the shaft (see Figure 5-9).
- C-19 Slide the center bearing (52) off of the shaft (see Figure 5-9).

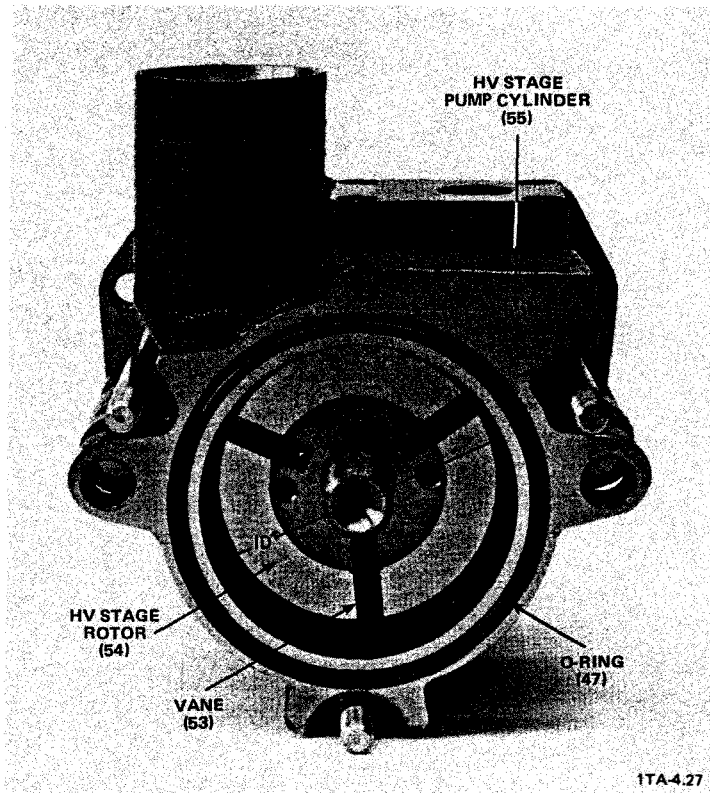

Figure 5-7. High Vacuum (HV) Stage Pump Cylinder (D2A Pump Model Shown)

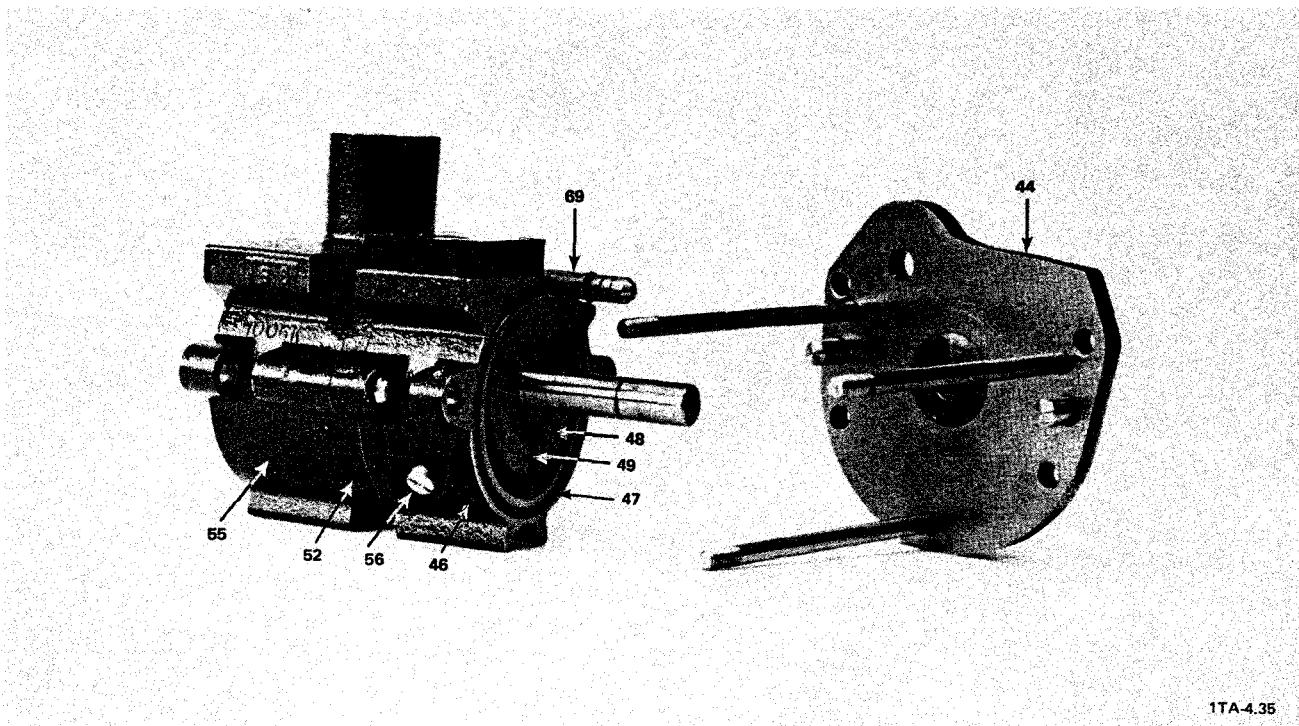

Figure 5-8. Second Stage Pump Cylinder (D2A Pump Model Shown)



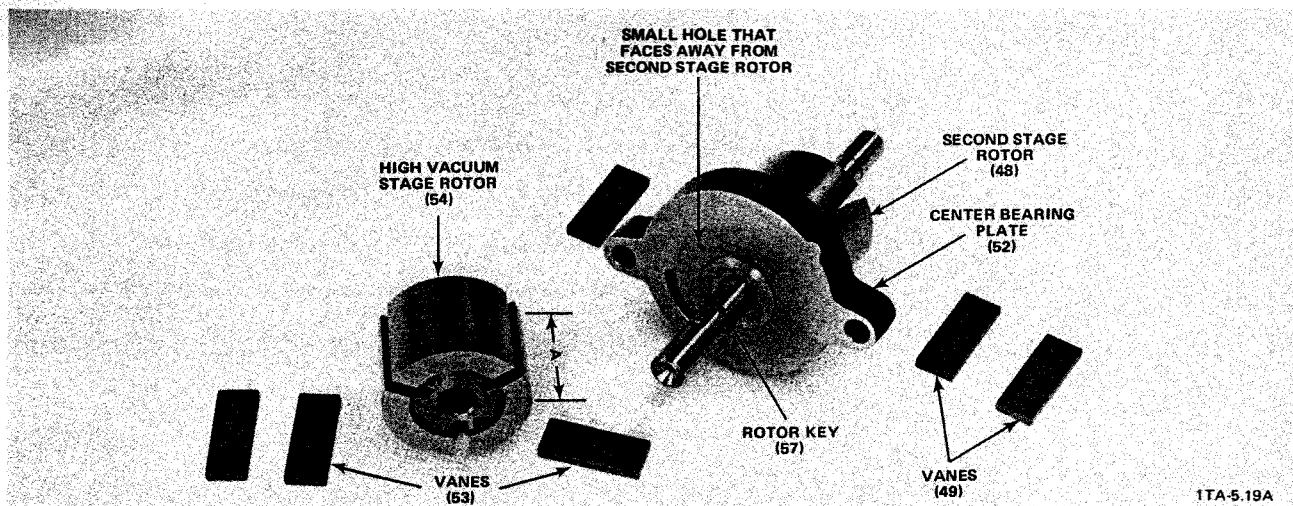

Figure 5-9. High Vacuum Stage Rotor Removed From the Shaft (D2A Pump Model Shown)

#### 5-D DISASSEMBLING THE REMAINING PARTS

- D-1** **WARNING:** D8A/AC THROUGH D90A/AC EXTREME-CORROSIVE SERVICE PUMPS HAVE AN ADAPTER EPOXIED TO THE TOP OF THE GAS BALLAST VALVE (SEE SKETCH 2-1). DO NOT REMOVE THIS ADAPTER OR DO STEP f FOR THESE PUMP MODELS. THE GAS BALLAST VALVE IS INTENTIONALLY PLUGGED ON D2A AND D4A EXTREME-CORROSIVE SERVICE PUMPS; THEREFORE, DO NOT DO STEPS a, d, e, AND f FOR PUMPS WITH INTENTIONALLY PLUGGED GAS BALLAST VALVES.

Disassemble the gas ballast valve as follows:

- a. For all pump models, pull the cap (18) off of the gas ballast valve (17). (See Figure 5-10A.)
  - b. For the D8A and D16A pump models only, use snap ring pliers to remove the retainer ring (34) from the gas ballast valve tube (17), then slide the cover (33) off of the tube (17).
  - c. For all pump models, slide the O-ring (27), flat gasket (29), and spring (28) off of the gas ballast valve (17) tube (see Figure 5-10B).
  - d. For the D2A and D4A pump models only, use a screwdriver to unscrew and remove the nonreturn valve (23) assembly from inside of the top of the gas ballast valve (see Figure 5-10A).
  - e. For the D2A and D4A pump models only, use a small screwdriver to unscrew and remove the strengthening piece (26), spring (25), and flat gasket (24) from the nonreturn valve (23). (See Figure 5-10A).
  - f. For D8A, D16A, D30A, D60A, and D90A pump models only, use a screwdriver to remove the retaining washer (21), valve (19), and O-ring (20) from inside of the top of the gas ballast valve (See Figure 5-10A).
  - g. For the D30A, D60A, and D90A pump models only, remove the retainer ring (30), valve plate washer (32), spring (31), and valve plate (32) from the tube end of the gas ballast valve (See Figure 5-10B).
- D-2** Remove the two O-rings (70) from the air inlet tube (69). (See Figure 5-11.)
- D-3** Remove the O-ring (3) from the dirt trap (2). (See Figure 5-11.)
- D-4** Remove the O-ring (5) from the end of the pump intake tube (1). (See Figure 5-11.)
- D-5** For D2A, D4A, D8A, and D16A pump models, pull the brass piston (68) from the valve disk (67). (See Figure 5-11.)  
For D30A, D60A, and D90A pump models, unscrew the brass piston (68) from the valve disk (67). (See Figure 5-11.)
- D-6** Remove the flat gasket (9) from each of the two plug screws (8). (See Figure 5-11.)

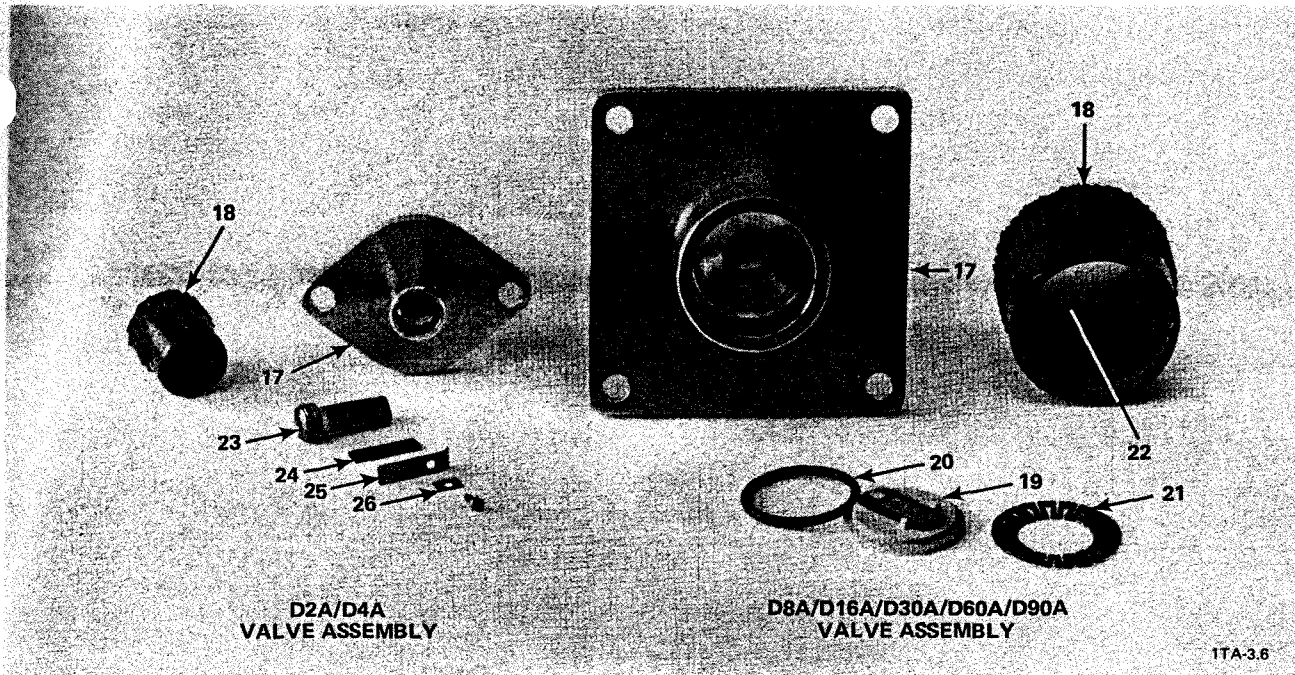
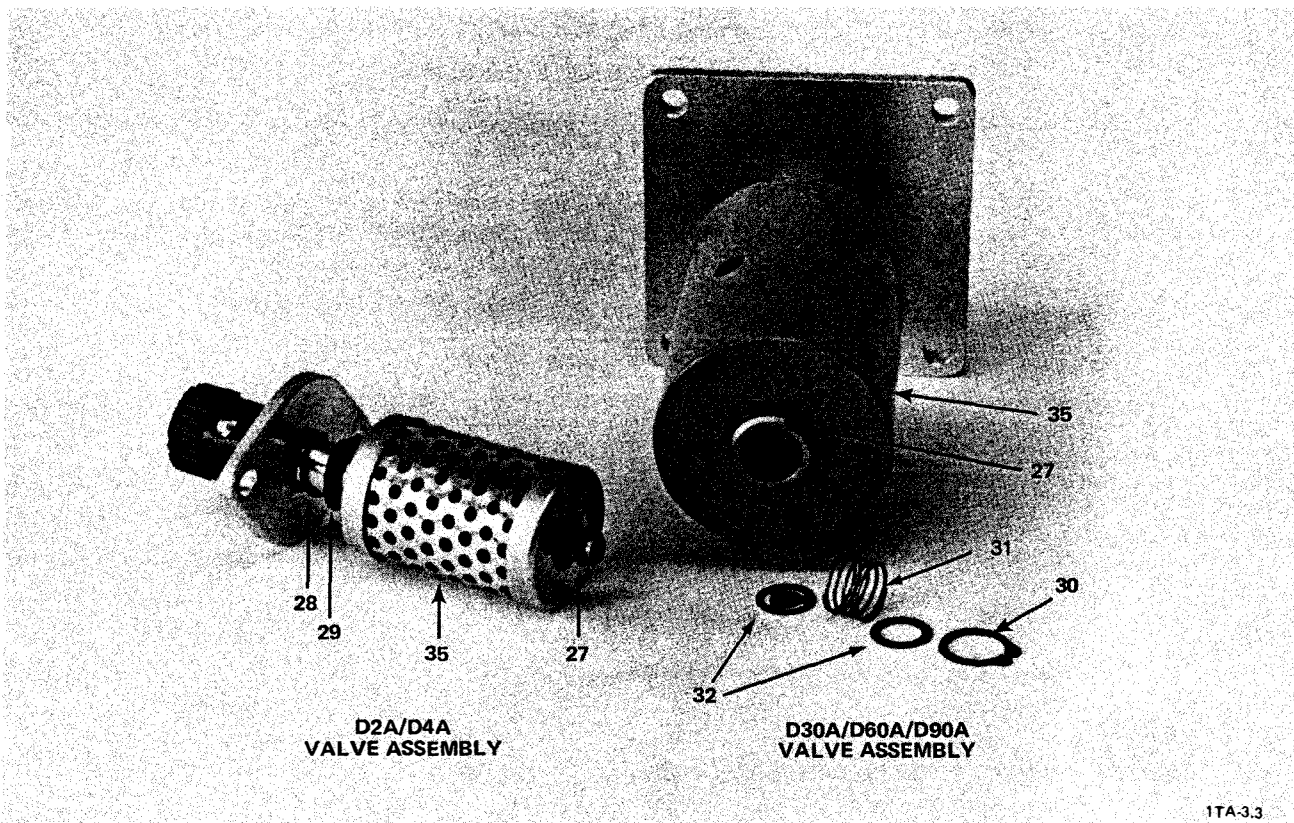
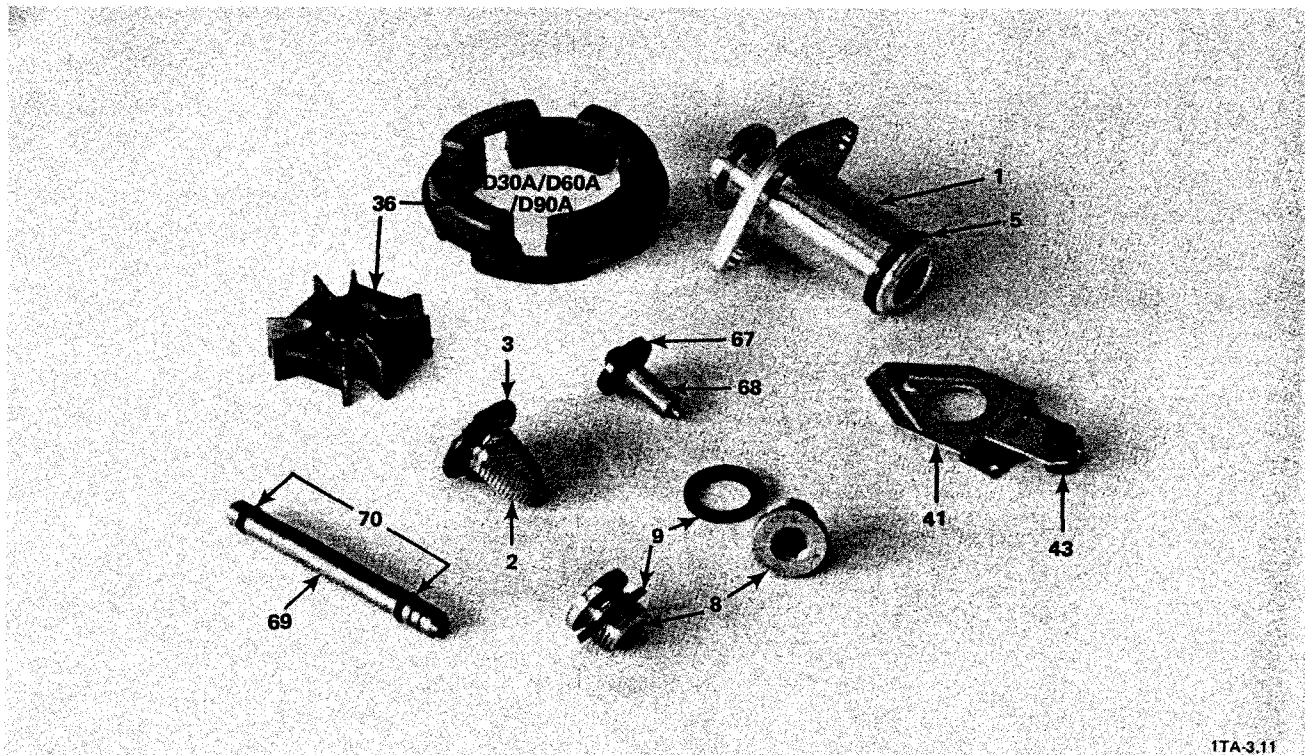

Figure 5-10A. Cap End of Gas Ballast Valve



**NOTE:** The tube end of the D8A/D16A gas ballast valve is similar to the D2A/D4A, except the D8A/D16A has a cover (33) and retainer ring (34) above the oil filter (35).

Figure 5-10B. Tube End of Gas Ballast Valve



17A-3.11

**NOTE;** All parts shown are from a D2A pump model, except for the D30A/D60A/D90A coupling ring (36).

Figure 5-11. Miscellaneous Disassembled Parts

- D-7 Remove the seal (43) from the lever (41). (See Figure 5-11.)
- D-8 **CAUTION:** BE CAREFUL TO AVOID SCRATCHING THE END PLATE OR INSIDE OF THE BRONZE BUSHING WHEN REMOVING THE RADIAL SHAFT SEAL. SCRATCHES TO THESE SURFACES COULD RESULT IN POOR PUMP PERFORMANCE.

Remove the radial shaft seal (45) from the rear end plate (60) as follows (see Figure 5-12).

- a. Place a thin wooden block on/or beside the end plate.
- b. **CAUTION:** DO NOT INSERT ANY TYPE OF PRYING DEVICE INTO OR THROUGH THE BRONZE BUSHING.

Insert the end of a screwdriver between the bronze bushing and the shaft seal (45). Rest the shaft of the screwdriver on the wooden block.

- c. Using the wooden block as a fulcrum and the screwdriver as a lever, pry the shaft seal (45) out of the end plate.

- D-9 Unscrew and remove the threaded studs (62) from the front end plate (44). (See Figure 5-12.)

**NOTE:** The D8A and D16A pump models have four threaded studs, rather than three.

**NOTE:** For use during reassembly, the ends of the threaded studs (62) that have the shorter threaded section screw into the front end plate (44) (see Figure 5-8). During reassembly, the threaded studs should be screwed until they are tight in the front end plate.

- D-10 Repeat Step D-8, except remove the shaft seal (45) from the front end plate (44).

- D-11 For the D4A, D16A, D60A, and D90A pump models only, use an allen wrench to remove the two screws that attach the retaining bracket (59) to the high vacuum pump cylinder (55). Remove the retaining bracket and the valve plate (58) from the pump cylinder (see Figure 5-13).

**NOTE:** The D2A, D8A, and D30A pump models do not have retaining brackets (59) and valve plates (58).

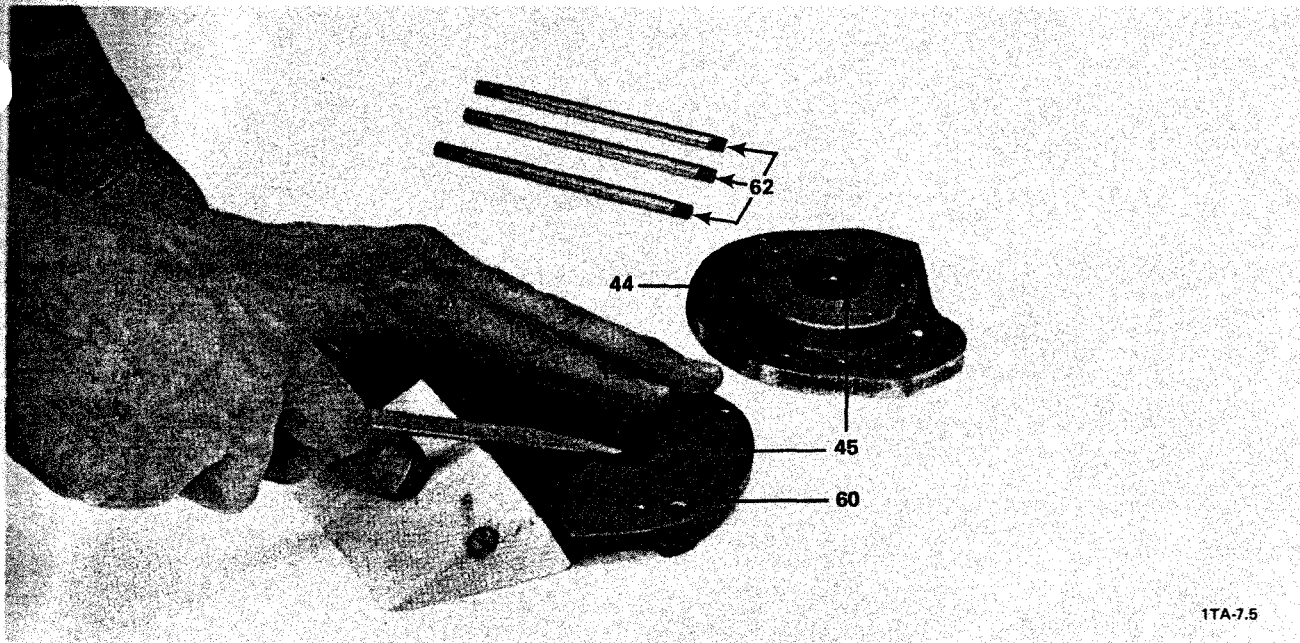

Figure 5-12. Removing the Radial Shaft Seal From the End Plates (D2A Pump Model Shown)

**NOTE:** The D60A and D90A pump model has two retaining brackets (59) and two valve plates (58) that must be removed.

**NOTE:** For use during reassembly, the thicker viton section of the valve plate (58) faces up.

**D-12 NOTE:** When removing the valve stop (51), observe the orientation of the valve stop, valve plate (50), and pump cylinder (46). It is important that these parts are placed in this same orientation during reassembly (see Figure 5-14).

Unscrew and remove the four screws that attach the valve stop (51) to the top of the second stage pump cylinder (46). Remove the valve stop (51) and thin metal valve plate (50) from the pump cylinder (46). (See Figure 5-14.)

**NOTE:** The valve stops (51) on the larger pumps are cast aluminum. On most of the smaller pumps, the valve stops are a black plastic.

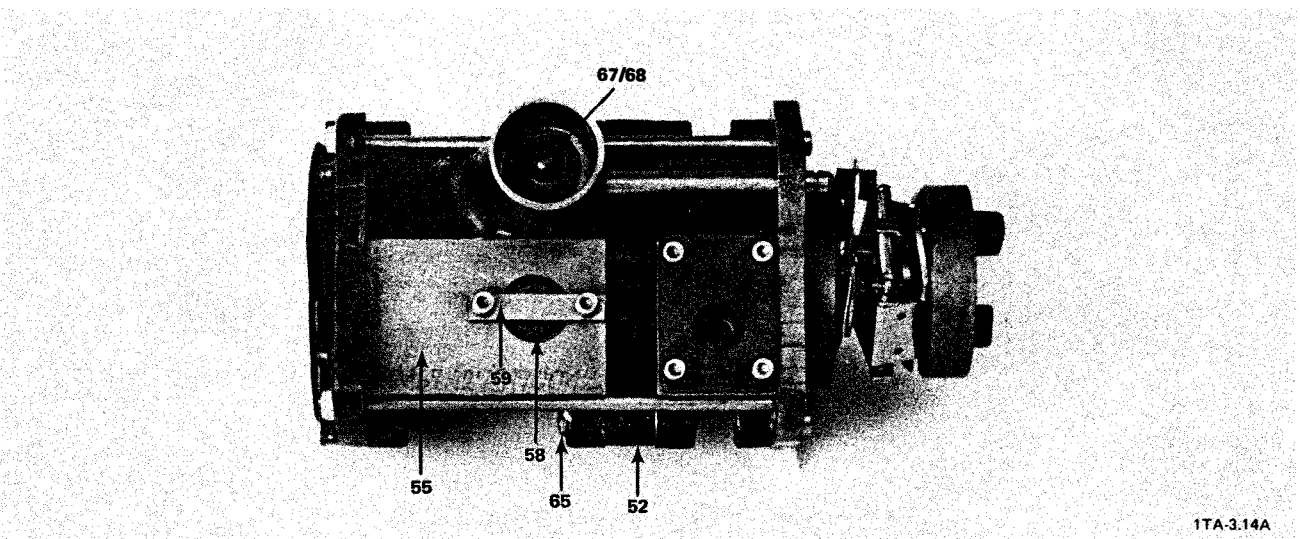
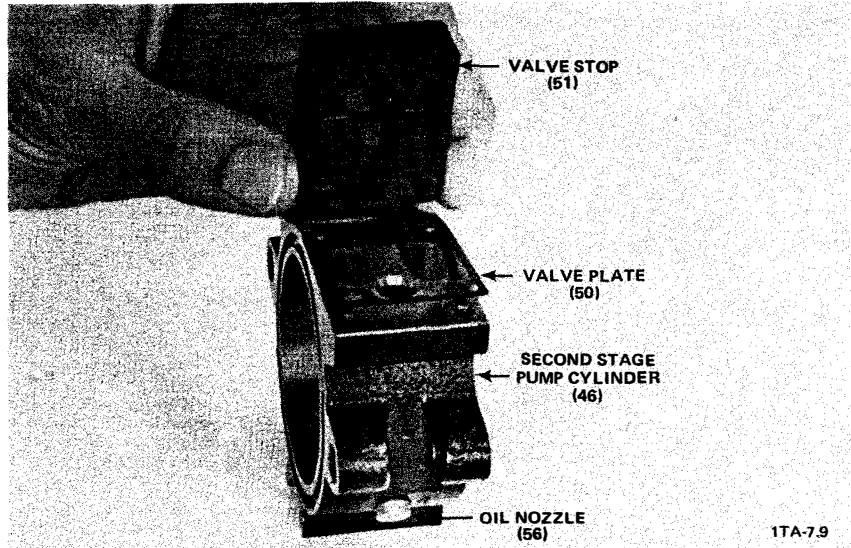

Figure 5-13. D4A Module Showing Retaining Bracket and Valve Plate





**NOTE:** The valve plate (50) on the D30A/D60A/D90A pump models has four tabs rather than two.

Figure 5-14. Removing the Valve Stop and Plate (D2A Pump Model Shown)

- D-13** Using a U.S. standard wrench, unscrew and remove the four nuts and washers that attach the motor (73) to the coupling housing (11). Remove the motor from the coupling housing (see Figure 5-15).
- D-14** For the D2A, D4A, D8A, and D16A pump models only, pull the elastic element (36) off of the coupling (37) mounted on the motor shaft (see Figure 5-15).
- For the D30A, D60A, and D90A pump models only, pull the coupling ring (36) off of the coupling (37) mounted on the motor shaft (see Figures 5-11, 5-3, and 5-15).
- D-15 CAUTION:** DO NOT USE CHANNEL LOCK PLIERS TO REMOVE THE OIL LEVEL GLASS ASSEMBLY FROM THE COUPLING HOUSING. USING CHANNEL LOCKS COULD RESULT IN DAMAGE TO THE OIL LEVEL GLASS ASSEMBLY.

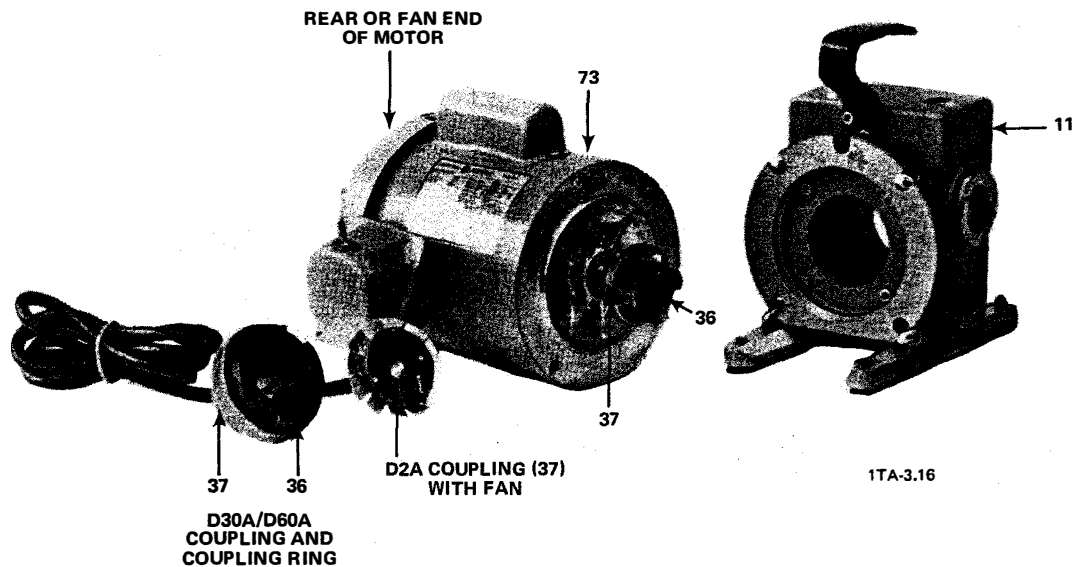

Figure 5-15. Coupling Housing and Motor (D2A Pump Model Shown)

**STEP D-15 CONTINUED**

If necessary for cleaning, remove and disassemble the oil level glass assembly (15) as follows:

- a. Use one of the following three methods to remove the oil level glass assembly from the coupling housing (11).

**Method (1)** – Unscrew the assembly using an adjustable spanner which has the correct pin locations to match the two holes in the assembly.

or

**Method (2)** – Place the nose ends of a large pair of snap ring pliers into the two holes in the assembly (15); insert a screwdriver or small bar between the nose ends of the snap ring pliers; use the screwdriver or bar to force the pliers and the assembly to turn counterclockwise; unscrew the assembly from the coupling housing (see Figure 5-16).

or

**Method (3)** – Place a sturdy pin, drift pin, or drill bit into each of the two holes in the assembly (15); cross the pins to form an "X"; insert a screwdriver or small bar through the oil-level-glass-assembly side of the "X"; use the screwdriver or bar to force the pins and the assembly to turn counterclockwise; unscrew the assembly (15) from the coupling housing (11).

- b. Disassemble the oil level glass assembly (15) as follows:

- (1) Using long nose pliers, unscrew the target piece from the assembly.
- (2) Push the glass and gaskets out of the assembly.

**5-E CLEANING AND INSPECTING THE DISASSEMBLED PUMP**

**CAUTION:** THE SECTION 5-E INSTRUCTIONS ARE FOR CLEANING PUMP PARTS. DO NOT USE THESE INSTRUCTIONS FOR CLEANING THE MOTOR.

It is not necessary to clean parts that will not be reused. A new valve disk (67) and elastic element (36), and all new seals, gaskets, and O-rings should be used for all pumps.

Use Freon TF or acetone to **clean all surfaces thoroughly**. For final rinse, use solvents such as alcohol or Freon TF.

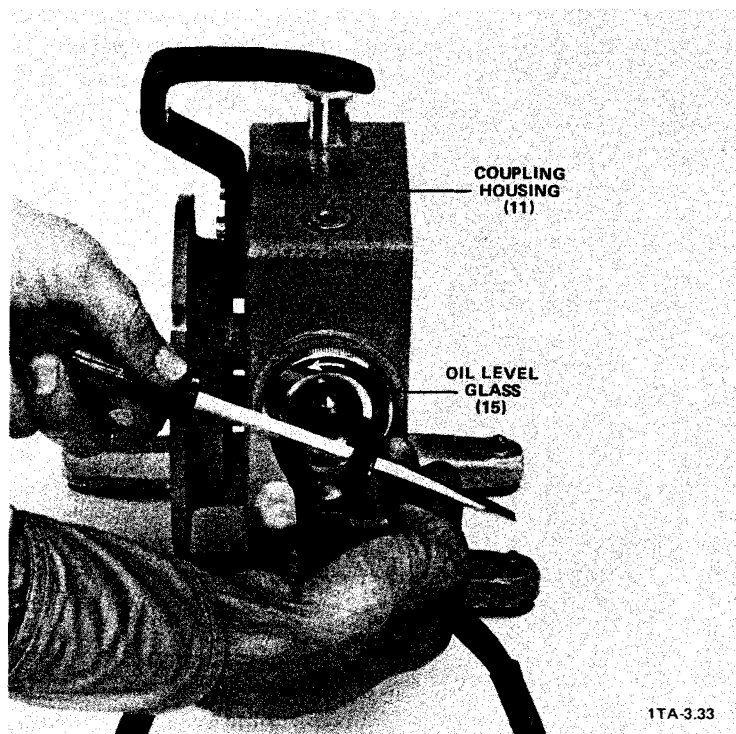

Figure 5-16. Removing the Oil Level Glass (15) From the Coupling Housing (D2A Pump Model Shown)

### 5-E-1 Special Requirements for Extreme-Corrosive Service Pumps

**WARNING: STEPS 1 THROUGH 4 BELOW MUST BE FOLLOWED FOR EXTREME-CORROSIVE SERVICE PUMPS.**

1. **NOTE:** New vanes (49/53) and a new oil filter (35) are required for extreme-corrosive service pumps; therefore, it is not necessary to do Step E-8c.

**REQUIRED ACTION:** Refer to Steps E-1 through E-8b(2) to clean and inspect all metal parts.

2. Degrease all tools that will be used for handling degreased extreme-corrosive service pump parts. Ensure that the working surface is free of any hydrocarbon substance.
3. Degrease and rinse all metal pump parts in a nonhydrocarbon solvent.
4. Wet all seals and all internal pump parts with the recommended perfluoropolyether pump fluid.

### 5-E-2 Instructions for Cleaning and Inspecting All Pump Models

Give particular attention to cleaning the following areas.

- E-1. Inspect all O-ring grooves for burrs and dirt. Sand and/or clean as necessary.

- E-2. **CAUTION: FAILURE TO REMOVE BURRS AND SCRATCHES FROM THE SHAFT COULD RESULT IN DAMAGE TO THE RADIAL SHAFT SEALS (45).**

Inspect the coupling key (38) and the shaft for burrs or scratches. Sand smooth, if necessary (see Figure 5-4).

- E-3. Ensure that all dirt accumulation is cleaned from all passages, including the following:

- a. The hole on the bottom edge of the front end plate (44) – this hole extends all the way to the bronze bushing.
- b. The small hole in or just above the rear-end-plate (60) and front-end-plate (44) bronze bushing (see Figures 5-6 and 5-8).
- c. The oil nozzle (56) hole in the second stage pump cylinder (46) – remove the oil nozzle screw and clean the screw and the hole (see Figure 5-14); then screw the oil nozzle (56) into its hole in the cylinder (46).

**NOTE:** The D30A, D60A, and D90A pump models have two oil nozzles that must be cleaned.

- d. **For D30A, D60A, and D90A pump models only,** clean the brass air nozzle screw (66) located inside of the intake tube portion of the high vacuum pump cylinder (55).
- e. The tiny silencing hole in the side of the gas ballast valve (17) stem just **below** the bolting flange - use fine wire to clear any dirt from the hole; **DO NOT ENLARGE THE HOLE.**

- E-4. Using a brush, thoroughly clean the center bearing (52). (See Figure 5-9.)

- E-5. Clean all dirt accumulation or buildup from the three vane slots in each rotor (48/54). (See Figure 5-9.)

- E-6. Visually inspect the air inlet tube (69) to ensure that it is clear of debris (see Figure 5-11).



E-7. Thoroughly clean the coupling housing (11), making certain that no dirt has accumulated in the crevices of the housing (see Figure 5-15).

E-8. Carefully inspect all parts for excessive wear. Give particular attention to the following:

- a. The ends of each rotor (48/54) may be wearing against the inside surface of the front (44) and rear (60) end plates or against the center bearing (52). Inspect these surfaces for gouges and wear (see Figure 5-8). If you observe scoring or wear, proceed as follows:
  - (1) Replace the plate that is scored.
  - (2) Check the rotors for burrs. If burrs are found, sand or file them smooth.
  - (3) Using calipers or micrometers, measure the length of each rotor (Dimension A of Figure 5-9). If the length dimension of either rotor is less than the dimension listed for your pump model in Table 5-1 (on the following page), replace that rotor.
- b. The shaft rides in bronze bushings in the front (44) and rear (60) end plates and in the center bearing (52) plate (see Figures 5-6, 5-8, and 5-9). Inspect the inside surface of these three bronze bushings for gouging or wear. If you observe deep gouging, replace the gouged shaft or the plate containing the gouged bushing. If you observe minor scratches or wear, proceed as follows:
  - (1) Using calipers or micrometers, measure the inside diameter (ID) of the bronze bushing. If the ID is greater than the dimension listed for your pump in Table 5-1, replace the end plate or center bearing plate containing the worn bushing.
  - (2) Using calipers, measure the outside diameter (OD) of the shaft at each area of wear. If the shaft OD at any point of wear is less than the dimension listed for your pump model in Table 5-1, replace the shaft.
- c. Three rectangular vanes (49/53) fit into slots in each rotor (48/54). (See Figures 5-7 and 5-8.) Using calipers or micrometers, measure the length and thickness dimension of each vane. If either dimension is greater than the maximum or less than the minimum dimension listed for your pump model in Table 5-1, replace that vane. If a vane dimension is greater than the maximum, it is the result of swelling due to chemical attack.

E-9. Using a paint brush, cover all the pump parts with a light coat of the proper pump fluid. (see Section 5-A-1).

## 5-F REASSEMBLING THE PUMP

New seals, gaskets, and O-rings and a new valve disk (67) and elastic element (36) should be used when re-assembling the pump. Use a new valve plate (50) only if wear is visible on the old valve plate. For extreme-corrosive service pumps, new vanes (49/53) and a new oil filter (35) are also used.

Wet the O-rings, gaskets, and seals with a film of the proper pump fluid before installing. Make certain that all O-rings, gaskets, seals, and all pump parts are clean before reassembly.

**F-1 CAUTION: IF THE PUMP ROTATES IN THE WRONG DIRECTION FOR TOO LONG, PUMP FLUID IS EJECTED OUT OF THE INTAKE TUBE (1) AND THE VALVE DISK (67) OR THE MOTOR MAY BE DAMAGED.**

Ensure that the direction of rotation of the motor is correct as follows:

- a. **Steps a(1) and a(2) are for the D30A pump models with single-phase motors and for all D2A, D4A, D8A, and D16A pump models.\***

See plate on motor for motor specifications.

**TABLE 5-1. ROTOR, BEARING, SHAFT, AND VANE CRITICAL DIMENSIONS**

| Pump Model  |                     | D2A    | D4A    | D8A    | D16A   | D30A    | D60A/D90A |
|---|---------------------|--------|--------|--------|--------|---------|-----------|
| Minimum Rotor Length (mm)                                   | S <sup>a</sup>      | 34.970 | 34.970 | 44.960 | 44.960 | 74.921  | 74.921    |
|   | HV <sup>a</sup>     | 34.970 | 69.970 | 44.960 | 89.960 | 74.921  | 149.890   |
| Maximum Bushing Diameters (mm)                              | F <sup>b</sup>      | 12.027 | 12.027 | 15.027 | 15.027 | 22.033  | 22.033    |
|   | C <sup>b</sup>      | 12.027 | 12.027 | 15.043 | 15.043 | 22.070  | 22.070    |
|   | R <sup>b</sup>      | 12.027 | 12.027 | 15.027 | 15.027 | 22.033  | 22.033    |
| Minimum Shaft Diameter at Points of Wear (mm)               |                     | 11.992 | 11.992 | 14.992 | 14.992 | 21.991  | 21.991    |
| Second Stage Vane Dimensions (mm)                           | L <sup>c</sup> max. | 34.991 | 34.991 | 44.991 | 44.991 | 74.990  | 74.990    |
|   | L <sup>c</sup> min. | 34.980 | 34.980 | 44.980 | 44.980 | 74.971  | 74.971    |
|   | T <sup>c</sup> max. | 4.47   | 4.47   | 4.47   | 4.47   | 4.47    | 4.47      |
|   | T <sup>c</sup> min. | 4.445  | 4.445  | 4.445  | 4.445  | 4.440   | 4.440     |
| High Vacuum Stage Vane Dimensions (mm)                      | L <sup>c</sup> max. | 34.991 | 69.990 | 44.991 | 89.988 | 74.990  | 149.986   |
|   | L <sup>c</sup> min. | 34.980 | 69.977 | 44.980 | 89.973 | 74.971  | 149.961   |
|   | T <sup>c</sup> max. | 4.47   | 4.47   | 4.47   | 4.47   | 4.47    | 4.47      |
|   | T <sup>c</sup> min. | 4.445  | 4.445  | 4.445  | 4.445  | 4.440   | 4.440     |
| Maximum Inside Diameter <sup>d</sup> of Pump Cylinders (mm) |                     | 54.830 | 54.830 | 78.630 | 78.630 | 118.535 | 118.535   |

a — S = second stage pump cylinder; HV = high vacuum stage pump cylinder.

b — F = front bushing; C = center bushing; R = rear bushing.

c — L = length; T = thickness; max. = maximum; min. = minimum.

d — See Figure 5-7.

- Step F-1 (a) (Cont'd.)
- a(1) **If the motor is single phase and it was supplied through Leybold**, it has been factory wired for correct rotation; therefore, it isn't necessary to check motor rotation unless you altered the wiring or replaced the motor. If the wiring was altered or the motor replaced, refer to Step a(2) below.
- a(2) **If the motor is 3-phase, or if it wasn't supplied through Leybold, or if its wiring was altered**, check the direction of rotation as follows:
- (a) Connect the power supply momentarily to jog the motor, and then immediately switch it off.

Step a(2) (Cont'd)

- (b) Check if the fan on the rear end of the motor is rotating in the correct direction. Looking from the fan end of the motor, the fan and motor shaft should be rotating clockwise (see Figure 5-15).
- (c) Turn off the motor and disconnect the power supply.
- (d) If the rotation direction is incorrect, reverse it by interchanging the electrical line connection at the motor end, then repeat Steps a(2) (a) through a(2) (c) above. For 3-phase motors, correct the direction of rotation by interchanging any two of the three phases.

**b. Steps b(1) and b(2) below apply only to D30A, D60A, and D90A pump models with three phase motors.**

- (1) If the pump has a new motor supplied by Leybold, a rotational lock bearing has been correctly installed at the factory to prevent the motor from rotating in the wrong direction. In this case, check the wiring of the motor as follows:

**CAUTION: FAILURE TO IMMEDIATELY TURN OFF THE MOTOR IF THE MOTOR FAN DOES NOT ROTATE COULD RESULT IN DAMAGE TO THE MOTOR AND THE PUMP.**

- (a) Connect the power supply and turn the motor on.
- (b) Check if the fan on the rear end of the motor (see Figure 5-15) rotates.
- (c) Turn off the motor and disconnect the power supply.
- (d) If the fan did not rotate, correct the motor wiring by interchanging any two of the three phases; then repeat Steps b(1) (a) through b(1) (c).

- (2) If the motor was not supplied through Leybold or the pump has an old Leybold supplied motor, grab the motor shaft or motor fan and attempt to turn it clockwise and then counterclockwise; then proceed as follows:

**CORRECTLY INSTALLED LOCK BEARING**

Looking from the fan end of the motor, if the fan or shaft will turn clockwise and will not turn counterclockwise, the pump has a correctly installed rotational lock bearing. In this case, do Steps b(1) (a) through b(1) (d) to check the wiring.

**LOCK BEARING INSTALLED BACKWARDS**

Looking from the fan end of the motor, if the fan or shaft will turn counterclockwise and will not turn clockwise, the rotational lock bearing is installed backwards. In this case, do Steps b(2) (a) through b(2) (s), which follow, to disassemble the motor and install the lock bearing correctly.

**NO LOCK BEARING OR MALFUNCTIONING LOCK BEARING**

If the fan or shaft will rotate in both directions, we recommend installing a rotational lock bearing. (See Steps b(2) (a) through b(2) (s).) If you have insufficient time to order and install a rotational lock bearing now, do Steps a(2) (a) through a(2) (d) to ensure correct rotation of the motor; then order and install a rotational lock bearing as soon as possible.

Proceed as follows to install a rotational lock bearing (see Figure 5-17). Note that the rotational lock bearing is installed on the fan end of the motor for all pump models except for D60A/D90A pump models with Marathon motors. The lock bearing on D60A/D90A's with Marathon motors is installed on the shaft end.

**NOTE:** Catalog numbers for the required parts and materials are listed in Table 5-2.

**NOTE:** If the motor is attached to the pump, remove the motor before proceeding with Steps (a) through (s).

- (a) Unscrew and remove the screws that attach the fan cover to the end of the motor. Remove the fan cover.

- Step F-1b (2) (Cont'd.) (b) For D30A pump models, use an allen wrench to loosen the setscrews that secure the fan to the shaft. Remove the fan.

For D60A and D90A pump models, loosen the screw that secures the fan to the shaft. Remove the fan; then use diagonal cutting pliers to remove the key from the shaft.

**NOTE:** For use during reassembly, the fan must be positioned on the shaft so that it does not contact the fan end-plate or the fan cover.

**TABLE 5-2. Parts Required for Installing the Rotational Lock Bearing**

| Pump Model | Quantity | Part Name   | Part Number |
|------------|----------|---|-------------|
| D30A       | 1        | Rotational Lock Bearing KK17                      | 99 104 0045 |
|            | 2        | Spring Washer                                     | 725 34 002  |
|            |          | Loctite 601                                       |             |
| D60A/D90A  | 1        | Rotational Lock Bearing KK35 for Marathon Motors* | 721 12 005* |
|            | 1        | Rotational Lock Bearing KK30 for GE Motors        | 721 12 004  |
|            | 2        | Spring Washers K 6206 for GE Motors               | 99 164 002  |
|            |          | Loctite 601 or 609                                |             |

\*For D60A and D90A pumps that have Marathon motors, the rotational lock bearing goes onto the shaft end of the motor, not on the fan end.

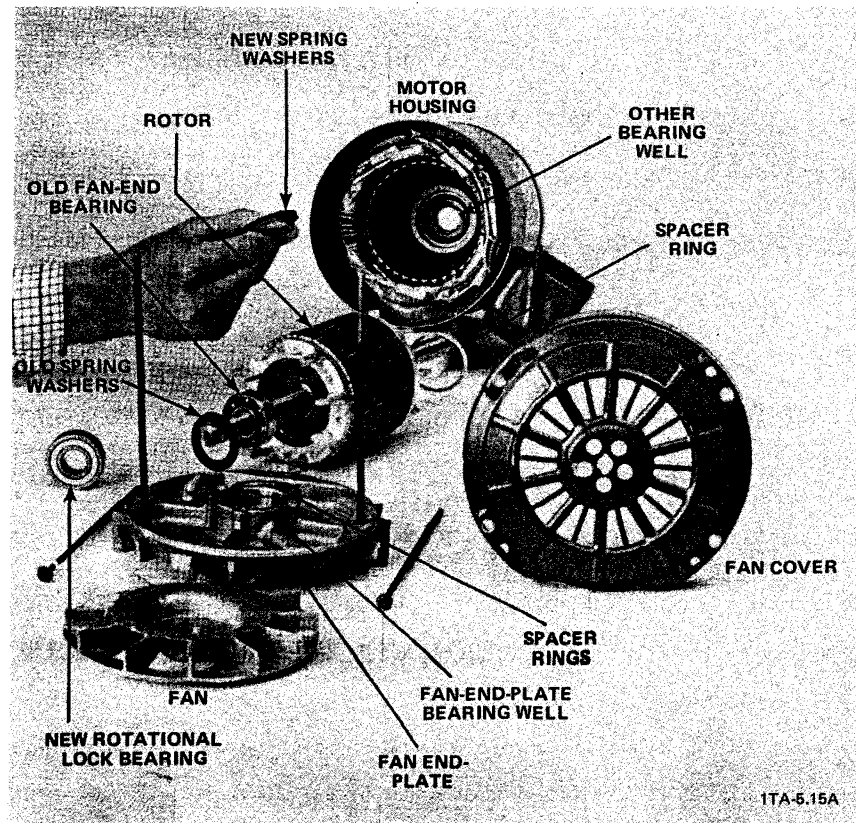

Figure 5-17. Disassembled Motor (D30A Motor Shown)

## Step F-1b (2) (Cont'd.)

- (c) Unscrew and remove the four hex head bolts that attach the fan end-plate to the motor. Use a hammer to tap the edge of the fan end-plate to remove it from the motor.

**NOTE:** If the motor has a malfunctioning rotational lock bearing, it will be necessary to use a torch to heat the center of the fan end-plate and the shaft. The heat should help loosen the Loctite 609 which bonds the OD of the rotational lock bearing to the fan-end-plate bearing well. The lock bearing is press fit and bonded to the shaft with Loctite. Additional heat may be required to separate the lock bearing from the shaft.

- (d) Except for D60A/D90A's with Marathon motors, remove and discard the three spring washers that fit between the fan end-plate and the bearing.
- (e) Remove the shaft and attached rotor from the motor housing.  
**NOTE:** It may be necessary to tap the other end of the shaft to free the shaft from the other end-plate.
- (f) **For D30A pump models only**, remove and save for reassembly the two spacer rings that fit into the fan-end-plate bearing well. Remove and discard the spacer ring that fits against the bearing on the other end of the shaft.
- (g) Grease the two new spring washers (see Table 5-2) and place them together so that the IDs are tight against each other and so that there is a gap between the ODs. (Figure 5-17 shows ungreased spring washers placed together as described above.)
- (h) Except for the D60A/D90A's with Marathon motors, reach through the motor housing to place the two new greased spring washers into the bearing well in the other end plate.
- (i) Except for the D60A/D90A's with Marathon motors, use a puller to remove and discard the fan-end bearing from the shaft.  
**NOTE:** The fan-end bearing is the smaller bearing.
- (j) **CAUTION:** IF ALL GREASE IS NOT REMOVED FROM THE MATING SURFACES, THE LOCTITE WILL NOT FORM A PERMANENT BOND AND THE ROTATIONAL LOCK BEARING WILL NOT WORK. THE BEST SOLVENT FOR THIS PURPOSE IS TRICHLOROETHANE. THE FOLLOWING SOLVENTS SHOULD NOT BE USED, SINCE THEY LEAVE A FILM ON THE SURFACE: KEROSENE, GASOLINE, NAPHTHA, FUEL OIL, VARSOL, AND STODDARD SOLVENTS.

**CAUTION:** DO NOT IMMERSE THE NEW ROTATIONAL LOCK BEARING IN SOLVENT. GREASE MUST REMAIN IN THE INSIDE OF THIS BEARING.

Wipe all grease from the bearing well in the fan end-plate, from the fan end of the shaft, and from the ID and OD of the new rotational lock bearing.

- (k) Reinstall the rotor and shaft in the motor housing.  
**NOTE:** When installed properly, the fan end of the shaft (the one with the bearing removed) will face you.
- (l) **CAUTION:** It is essential that the rotational lock bearing is placed on the shaft in a way which allows the **Inner Bearing Sleeve** to rotate clockwise. Except for the D60A/D90A's with Marathon motors, the side of the bearing that has the bearing's name and number stamped in it should face toward the center of the motor. Occasionally, the name and number are stamped on the wrong side of this bearing. To double check, hold the OD of the rotational lock bearing so that the side with the stamped name and number faces the rotor. While holding the OD tight, rotate the ID. If the ID rotates only in the clockwise direction, the rotational lock bearing is positioned correctly.

Step F-1 (b) (2) (Cont'd.)

- (m) **CAUTION:** FAILURE TO EVENLY DRIVE THE ROTATIONAL LOCK BEARING DOWN THE SHAFT COULD RESULT IN GALLING OF THE BEARING ID.

**REQUIRED ACTION:** Apply Loctite 609 to the area of the shaft where the bearing will fit and to the ID of the new rotational lock bearing. Using a hammer and a pipe that has an ID greater than the shaft OD, gently tap the rotational lock bearing down over the shaft until it bottoms out. Wipe off any excess Loctite.

- (n) **CAUTION:** It takes about 5 minutes for loctite 609 to begin setting. For D30A pump models, Steps (o) and (p) should be completed before the Loctite has time to set, in case the end plate must be removed.

Apply Loctite 609 to the OD of the new rotational lock bearing and to the ID of the mating bearing well in the end plate.

- (o) Repeat Steps (f), (c), and (b), except assemble rather than disassemble.
- (p) **For D30A pump models only,** spin the fan to check if the motor rotates freely. If there is a lot of friction, immediately remove the fan and the fan end-plate before the Loctite has time to set; then remove and discard one of the spacer rings and reassemble the motor.
- (q) Using the four screws, attach the fan cover to the motor.
- (r) Spin the shaft to check if the fan contacts the fan cover or fan end-plate. If it does, remove the fan cover and adjust the position of the fan on the shaft; then reassemble.
- (s) **NOTE:** Allow the motor to sit for at least 1½ hours prior to testing. This will allow the loctite time to cure and firmly bind the surfaces.

**REQUIRED ACTIONS:** Use the instructions at the beginning of Step b(2) to determine if the rotational lock bearing is installed correctly and to correct the problem if the lock bearing is installed backwards or is malfunctioning.

If the lock bearing is installed correctly, repeat Steps b(1) (a) through b(1) (d) to check the wiring of the motor.

- F-2 NOTE:** When reassembling the valve plate (50) to the second stage pump cylinder (46), ensure that the bent tabs that cover the exhaust holes are facing down. If the tabs are not bent, it does not matter which side is facing down.

Repeat Steps D-15 through D-11, D-9, and D-7 through D-2, except assemble rather than disassemble.

- F-3 CAUTION:** NICKS OR TEARS IN THE RADIAL SHAFT SEAL COULD RESULT IN A LUBRICATING FLUID LEAK AND POOR PUMP PERFORMANCE.

**CAUTION:** FAILURE TO RECESS THE RADIAL SHAFT SEAL (45) IN ITS SLOT IN THE REAR END PLATE (60) WILL RESULT IN THE VANES (53) RUBBING AGAINST THE SEAL (45) DURING PUMP OPERATION.

**NOTE:** The side of the seal that has a small circular spring around the ID faces the bronze bushing in the rear end plate (60).

**REQUIRED ACTION:** Use one of the following methods to install a new radial shaft seal (45) in the rear end plate (60) (see Figure 5-12).

**Method (1)** – Insert the new seal into its slot in the rear end plate. Using a hammer and a seal driver (see Figure 5-22), recess the seal in the slot.

or

**Method (2)** – Insert the new seal into its slot in the rear end plate. Place the used seal over the new seal. Use a hammer to tap the used seal until it indents the new seal in its slot in the rear end plate. Remove and discard the used seal.

F-4 Assemble the gas ballast valve (20) as follows:

- a. For D8A, D16A, D30A, D60A, and D90A pump models only, reassemble the insides of the cap end of the gas ballast valve (17) as follows (see Figure 5-10A).
  - (1) Fit the O-ring (20) around the inner rim of the valve plate (19). The O-ring goes onto the side of the valve plate that has the metal valve.
  - (2) Insert the valve plate (19)/O-ring (20) assembly into the top of the gas ballast valve (17). The side of the valve plate that has the metal valve faces down.
  - (3) Push the retaining washer (21) into the top of the gas ballast valve until it is tight against the valve plate (19).
- b. For D30A, D60A, and D90A pump models only, insert the parts into the inside of the tube end of the gas ballast valve in the following order (see Figure 5-10B).
  - First – Valve plate (32) that has three slots.
  - Second – Spring (31).
  - Third – Valve plate (32) washer.
  - Fourth – Retainer ring (30). Fit the retainer ring into the groove in the inside of the gas ballast valve tube.
- c. Repeat Steps D-1e through D-1a, except assemble rather than disassemble.

F-5 Assemble the high vacuum stage rotor (54) and the center bearing (52) to the shaft as follows (see Figures 5-9 and 5-18).

- a. **NOTE:** The second stage rotor (48) is permanently attached to the shaft on the D2A, D4A, D8A, and D16A pump models.

**NOTE:** If the center bearing plate (52) does not have the small hole, it can face either direction.

Coat the bronze bushing with the proper pump fluid and slide the center bearing (52) onto the shaft so that the side of the center bearing (52) with the small hole faces away from the second stage rotor (48) (see Figure 5-9).

- b. Insert the rotor key (57) into its slot in the shaft. Tap the key (57) down into its slot.
- c. **NOTE:** The end of the high vacuum stage rotor (54) with the two pulling holes is the outside end.

Align the slot in the ID of the high vacuum stage rotor (54) with the rotor key (57) in the shaft. Slide the rotor (54) onto the shaft. The rotor (54) must slide freely on the shaft.

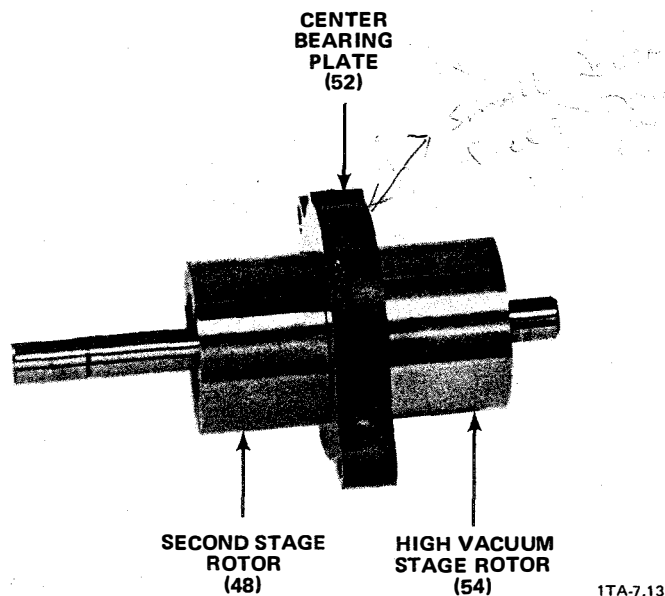

Figure 5-18. Rotors/Shaft/Center Bearing Plate Assembly (D2A Pump Model Shown)



**F-6 CAUTION:** FAILURE TO ENSURE THAT THE O-RINGS (47) REMAIN IN THEIR GROOVES DURING MODULE ASSEMBLY WILL RESULT IN DAMAGE TO THE O-RINGS AND POOR PUMP PERFORMANCE.

**NOTE:** The module assembly sequence (Steps F-6a through F-6j) is designed to keep the loose O-ring facing up, so that it does not fall out of its O-ring groove.

**CAUTION:** WHEN ASSEMBLING THE MODULE, DO NOT SCRATCH THE ENDS OF THE ROTORS OR THE INSIDE SURFACES OF THE PUMP CYLINDERS OR END PLATES. SCRATCHES TO THESE SURFACES COULD RESULT IN POOR PUMP PERFORMANCE.

**NOTE:** To ensure that each part is oriented correctly, refer to Figure 5-3 and follow each step precisely (Steps F-6a through F-6j).

**REQUIRED ACTION:** Assemble the module as follows:

- a. Place the high vacuum (HV) stage cylinder (55) so that it is lying flat with the intake tube portion (the top) on the right facing away from you (see Figure 5-19). Fit an O-ring (47) into the O-ring groove on the cylinder (55) surface that is facing up.
- b. Attach the assembly that you put together in Step F-5 to the HV stage pump cylinder (55) as follows:

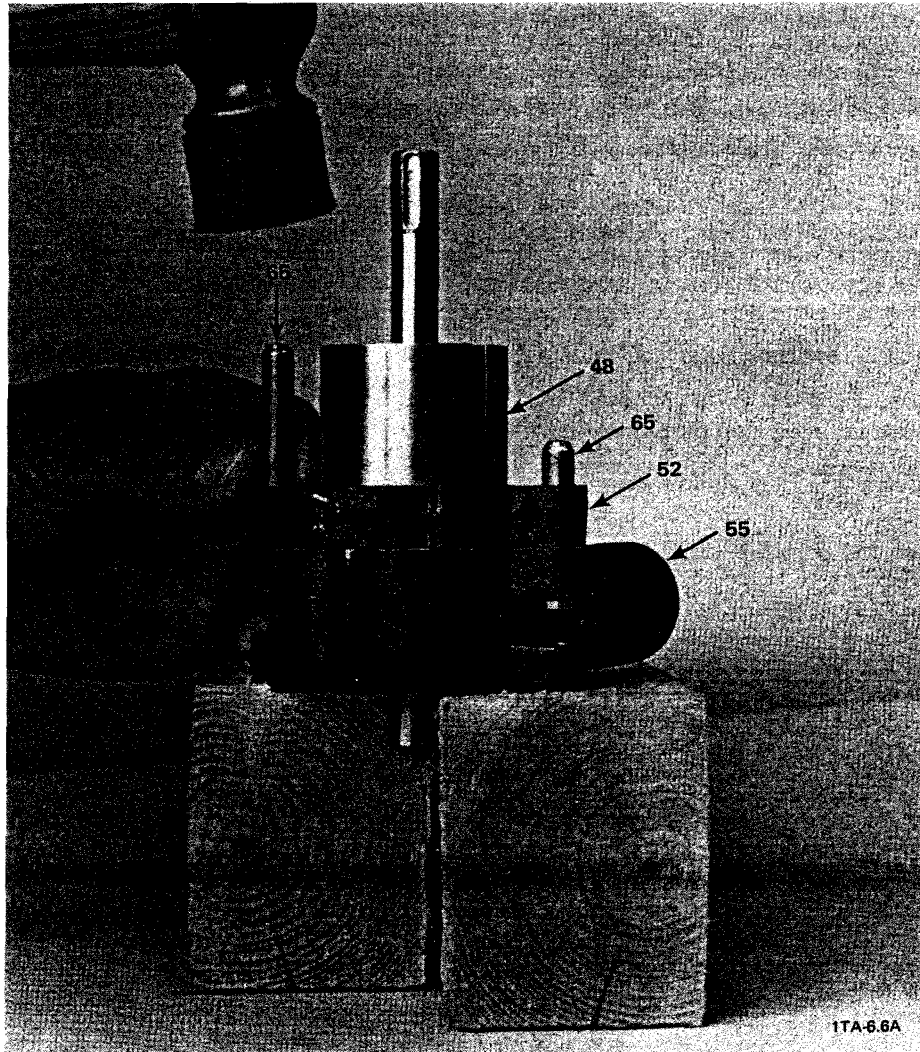

Figure 5-19. Driving the Long Cylindrical Pins that Align the HV Cylinder and the Center Bearing (D2A Pump Model Shown)

**Step F-6 b (Cont'd.)** (1) Take the Step F-5 assembly and insert its HV-stage end (the end that has two pulling holes on the outside end of the rotor) down into the HV stage cylinder (55) until the center bearing plate (52) rests against the HV stage cylinder (55) (see Figure 5-19).

(2) Align the two alignment holes in the center bearing plate (52) with the two upper alignment holes on the HV stage cylinder (55). (See Figure 5-19).

(3) **NOTE:** When driving the two long cylindrical pins (65) into the alignment holes, the flat end (nonbeveled end) of the pins (65) should face the HV cylinder (55). The HV cylinder is the one with the intake tube portion.

**REQUIRED ACTION:** Using a rubber hammer, hit the beveled end of the pins to drive the two long cylindrical pins (65) down through the two alignment holes in the center bearing plate (52), then through the two upper alignment holes in the HV cylinder (55) until the flat end of each pin extends just out of each upper HV-cylinder alignment hole (see Figure 5-19).

(4) Ensure that the center bearing plate (52) and the HV stage cylinder (55) are tight against each other and that they remain tight throughout the module assembly sequence.

c. Place the second stage pump cylinder (46) so that it is lying flat with the top edge (the flat portion that has the screw holes, exhaust holes, and gas ballast hole) on the right facing away from you. Fit an O-ring (47) into the O-ring groove on the cylinder (46) surface that is facing up.

**For D30A, D60A, and D90A pump models,** the second stage cylinder (46) should be lying flat on an open vice or other open support, so that the shaft can be inserted through it in Step d(3).

d. Attach the assembly that you put together in Step b(3) to the second stage pump cylinder as follows (see Figure 5-20):

(1) Take the assembly from Step b(3) and insert its second-stage end (the end that has the longer section of the shaft) down into the second stage pump cylinder (46).

(2) **NOTE:** When aligned correctly, the flat portions of the top of the two pump cylinders (46/55) are in line with each other.

**REQUIRED ACTION:** Align the beveled end of the two long cylindrical pins (65) (the pins which extend out of the alignment holes in the center bearing plate (52)) with the two upper alignment holes in the second stage cylinder (46).

(3) **NOTE:** When Step d(3) is completed, the beveled ends of the two long cylindrical pins (65) should extend most of the way through the upper alignment holes in the second stage pump cylinder (46).

**REQUIRED ACTION:** For the D2A, D4A, D8A, and D16A pump models, while keeping the assembly vertical, pull the second stage cylinder (46) straight up over the long cylindrical pins (65) until it is tight against the center bearing plate (52) (see Figure 5-20).

**For the D30A, D60A, and D90A pump models only,** while keeping the assembly vertical, push the Step b(3) assembly straight down until it is tight against the second stage cylinder (46).

(4) Ensure that the cylinders (46/55) and center bearing plate (52) remain tight against each other throughout the module assembly sequence.

e. **NOTE:** If you are reusing the old vanes (53), make sure that each used vane is replaced in its same rotor slot. Also make sure that the orientation of each vane is the same as it was before disassembly so that each used vane is not turned end-for-end in its slot.

**NOTE:** Be sure that the slotted edge of the vanes (53) faces the center of the rotor (54) when inserting the vanes into the rotor.

**NOTE:** For the D4A, D16A, D60A, and D90A pump models only, the high vacuum stage rotor (54) and vanes (53) are longer than the second stage rotor (48) and vanes (49). For these pump models, be sure to insert the longer vanes (53) into the high vacuum stage rotor (54).

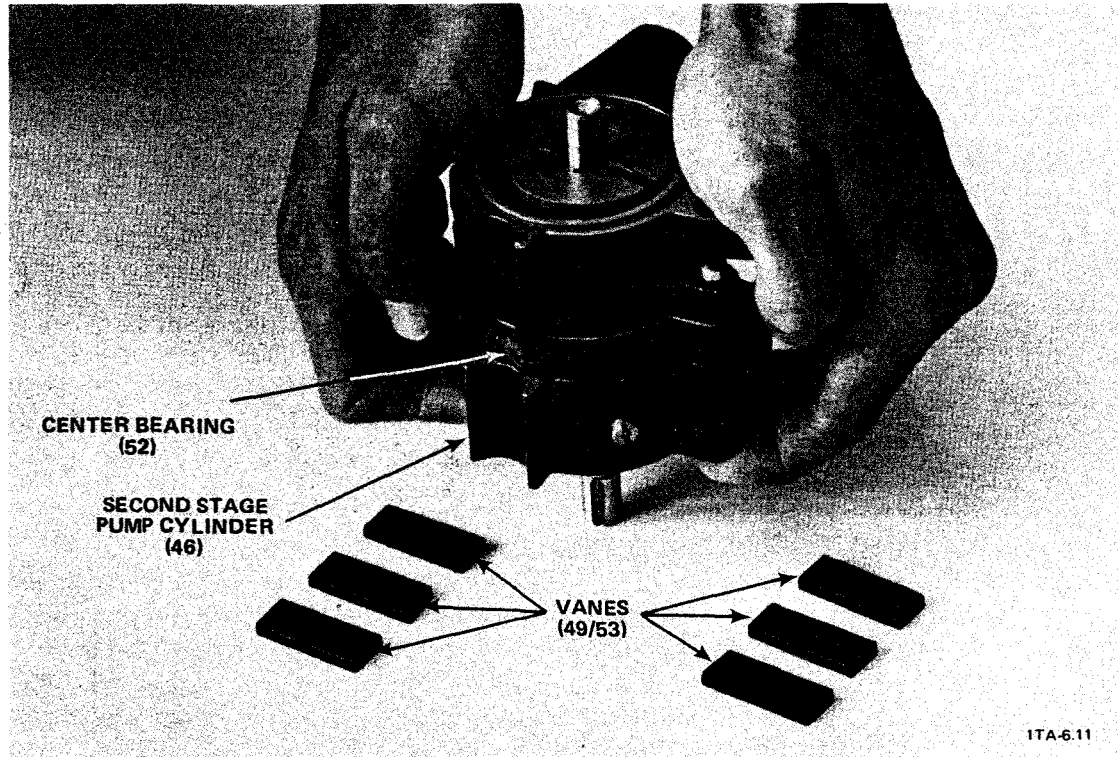

Figure 5-20. Pulling the Second Stage Pump Cylinder Tight Against the Center Bearing (D2A Pump Model Shown)

Step F-6 e (Cont'd.)

**REQUIRED ACTION:** Repeat Step C-11, except assemble rather than disassemble, to insert the three vanes (53) into the slots in the high vacuum stage rotor (54).

- f. While keeping the partially assembled module vertical, fit an O-ring (47) into the O-ring groove on the HV-cylinder (55) surface that is facing up (see Figure 5-20).
- g. Attach the rear end plate (60) to the partially assembled module as follows:

- (1) **NOTE:** Be sure to attach the rear end plate (60) to the HV-stage end of the module. The HV pump cylinder (55) is the one with the intake tube portion.

**NOTE:** The side of the rear end plate (60) that has the bronze bushing faces out.

**REQUIRED ACTION:** While keeping the partially assembled module vertical, align the rear-end-plate bushing hole with the shaft. Slide the rear end plate (60) down over the shaft until the machined surface of the rear end plate fits tight against the HV stage cylinder (55).

- (2) Align the two alignment holes in the rear end plate (60) with the two alignment holes in the HV cylinder (55), then use a rubber hammer to drive two short cylindrical pins (64) until the pin ends are slightly recessed in their alignment holes in the rear end plate (60) (see Figure 5-21).
- h. Turn the partially assembled module over so that the other end faces up, then fit an O-ring (47) into the O-ring groove in the second stage pump cylinder (46).

- i. **CAUTION:** DO NOT CHIP, SCRATCH, OR BREAK THE EDGES OF THE VANES.

**NOTE:** If you are reusing the old vanes (49), make sure that each used vane is replaced in its same rotor slot. Also make sure that the orientation of each vane is the same as it was before disassembly so that each used vane is not turned end-for-end in its slot.

**NOTE:** Be sure that the slotted edge of the vanes (49) faces the center of the rotor (48) when inserting the vanes into the rotor.

F-6 i (Cont'd.)

**REQUIRED ACTION:** Use long nose pliers to insert the three vanes (49) into the slots in the second stage rotor (48) (see Figure 5-8).

j. Attach the front end plate (44) to the partially assembled module as follows:

(1) **NOTE:** The side of the front end plate (44) that has the threaded studs (62) extending out of it faces the second stage cylinder (46) (see Figure 5-21). The edge of the front end plate that has a small hole is the bottom edge.

**REQUIRED ACTION:** While keeping the partially assembled module vertical, align the front-end-plate bushing hole with the shaft and align the threaded studs (62) with their mating holes in the rear end plate (60). Slide the front end plate (44) down over the shaft until the plate (44) fits **tight** against the second stage cylinder (46). Install the washers and nuts hand-tight onto the threaded studs.

(2) **NOTE:** If the two remaining cylindrical pins (64) have a beveled end, the beveled end should face away from the center of the module.

**REQUIRED ACTION:** Align the two alignment holes in the front end plate (44) with the two alignment holes in the second stage cylinder (46). Using a rubber hammer, drive the remaining two cylindrical pins (64) into the alignment holes until the pins (64) extend about 3/16 inch out of the outside surface of the front end plate (44) (see Figure 5-22).

k. **CAUTION:** NICKS OR TEARS IN THE RADIAL SHAFT SEAL COULD RESULT IN A LUBRICATING FLUID LEAK AND POOR PUMP PERFORMANCE.

**NOTE:** The side of the seal that has a small circular spring around the ID faces the bronze bushing in the front end plate.

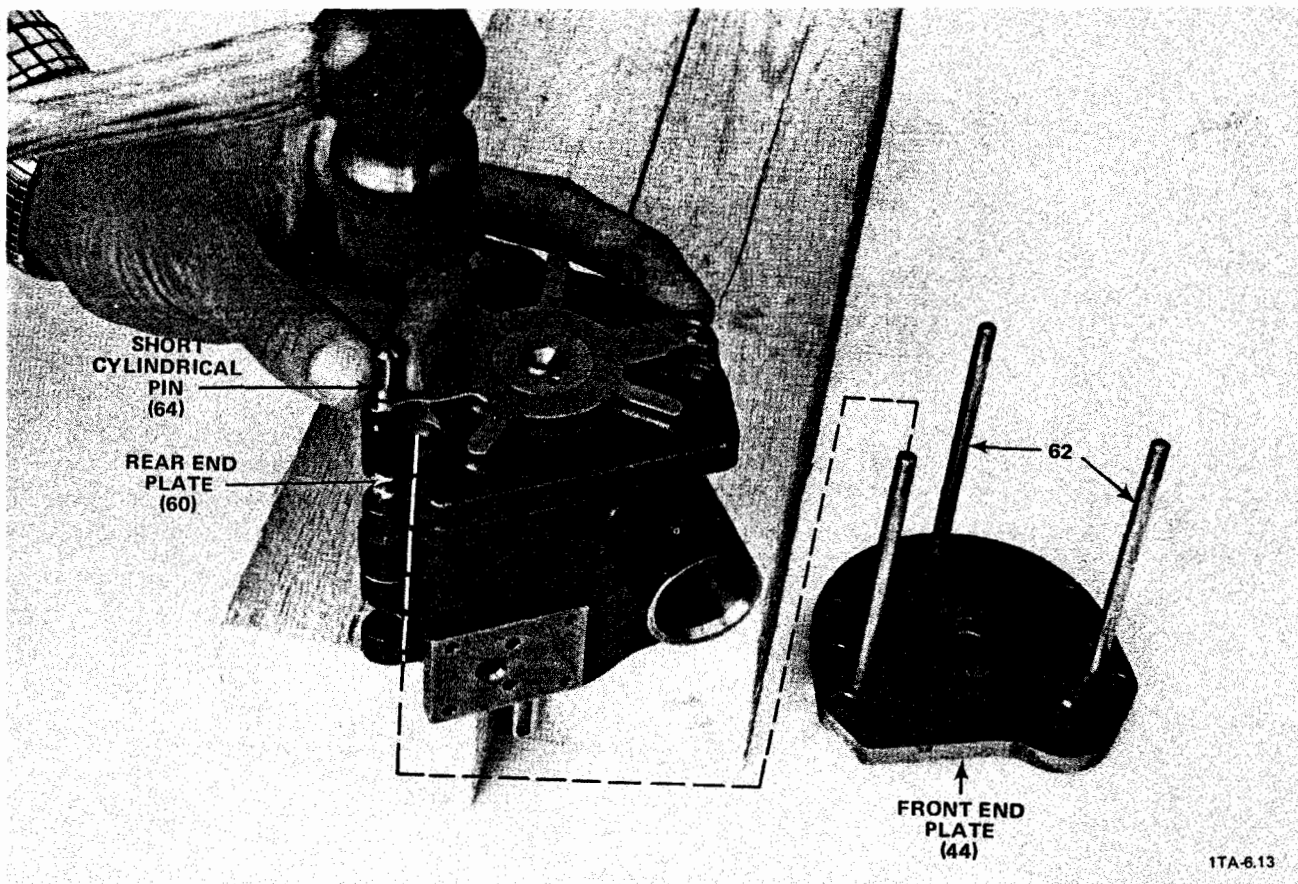

Figure 5-21. Driving the Short Cylindrical Pins that Align the Rear End Plate and the HV Cylinder (D2A Pump Model Shown)

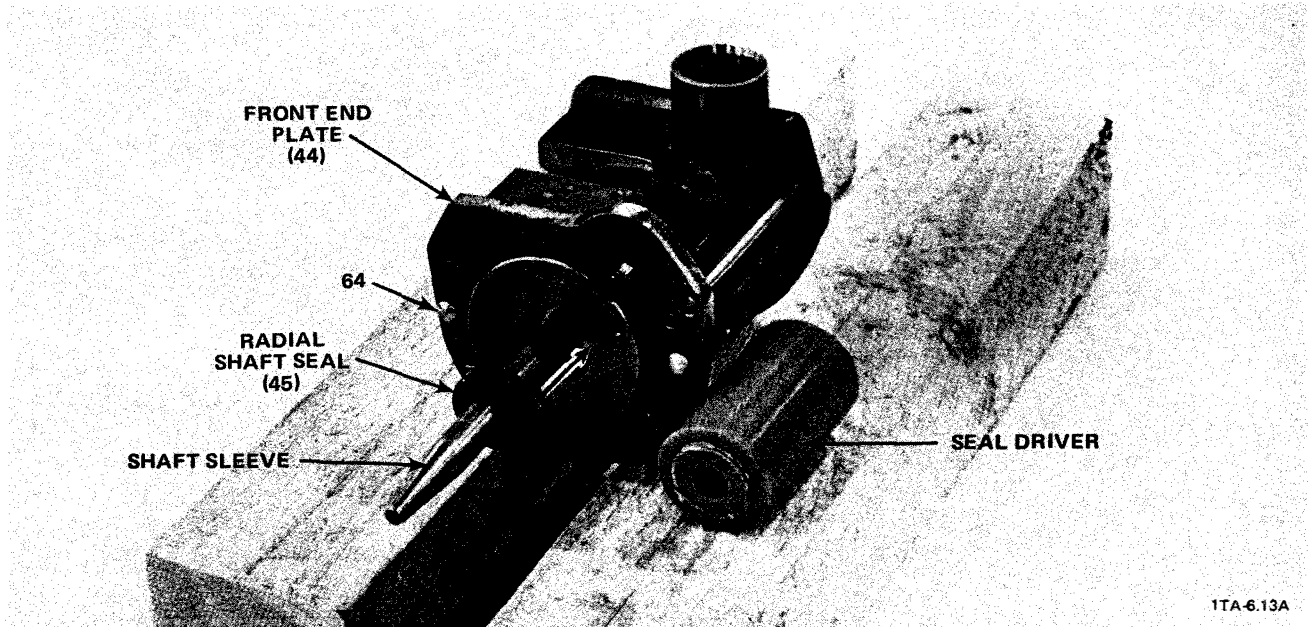

Figure 5-22. Using a Shaft Sleeve to Install the Radial Shaft Seal into the Front End Plate (D2A Pump Model Shown)

Step F-6 k (Cont'd.)

**REQUIRED ACTION:** Install the radial shaft seal (45) into the front end plate (44) as follows:

(1) Insert the seal using one of the following methods.

**Method (a)** — Insert a shaft sleeve over the shaft (see Figure 5-22); slide the seal (45) over the shaft sleeve and insert the seal into its slot in the front end plate; remove the shaft sleeve from the shaft.

or

**Method (b)** — Place cellophane tape over the shaft to prevent the seal from being cut or nicked; carefully slide the seal (45) over the shaft and insert the seal into its slot in the front end plate; remove the tape from the shaft.

(2) Recess the seal (45) using one of the following methods.

**Method (a)** — Slide a seal driver over the shaft; using a hammer, strike the seal driver to indent the seal into its slot in the front end plate; remove the seal driver from the shaft (see Figure 5-22).

or

**Method (b)** — Slide the used seal over the shaft until it is against the new seal; using a hammer, tap evenly around the used seal to indent the new seal into its slot in the front end plate; remove and discard the used seal.

**F-7 NOTE:** The end of the air inlet tube with the beveled tip and circumferential slots is the outside end (see Figure 5-4).

Install the air inlet tube (69) into the module as follows (see Figure 5-4):

- a. Push the air inlet tube through the hole in the top of the front end plate (44). When installed properly, two of the three circumferential slots in the end of the air inlet tube should extend out of the outside surface of the front end plate (44).
- b. Insert the retainer disk (71) into the second slot from the beveled tip of the air inlet tube (69).

**NOTE:** The other end of the air inlet tube (69) fits into the hole in the base of the intake portion of the high vacuum pump cylinder (55) (see Figure 5-4).

**F-8 CAUTION:** USE CARE WHEN HANDLING THE MODULE TO AVOID BENDING THE LEVER (41) OR CENTRIFUGAL SWITCH (39). (This CAUTION also applies to Steps F-9 through F-12.)

Repeat Steps C-9, C-6, C-5, C-4, and C-3, except assemble rather than disassemble.



- F-9** Install the coupling (37) onto the module shaft as follows (see Figures 5-3 and 5-4).
- Align the slot in the coupling with the key (38) on the shaft.
  - Slide the coupling onto the shaft until it rests against the retainer ring (40).
  - Screw the coupling setscrew clockwise until it is tight.
- F-10** Grab the coupling (37) and turn the module shaft (see Figure 5-3). If the end plates (44/60), pump cylinders (46/55), and center bearing (52) are aligned properly, the shaft will turn smoothly. If there is **any** binding, adjust the alignment as follows:
- Loosen the hexagon nuts (63) on the threaded studs (62) (see Figure 5-6).  
**NOTE:** The D16A and D8A pump models have four rather than three nuts and studs.
  - CAUTION: BEFORE STRIKING THE REAR END PLATE (60), ENSURE THAT THE DISK (61) (see Figure 5-2) IS NOT ASSEMBLED TO THE MODULE.**  
Strike the face of the rear end plate (60) a couple of times while cross-tightening the hexagonal nuts (63) (see Figure 5-6). Tighten these nuts until all are snug.
  - Grab the coupling (37) and turn the module shaft to see if the shaft turns smoothly (see Figure 5-3). Many times the act of turning the shaft will bring the module into alignment.
  - Continue repeating Steps F-10a through F-10c until the shaft turns smoothly and there is **no** binding. It is sometimes necessary to loosen or tighten each hexagon nut several times to eliminate all binding. Many times, it is necessary to tighten two of the nuts (63) and loosen the other nut(s) a bit. However, all nuts should be tightened to roughly the same torque.
  - Test the breakaway torque of the shaft. It must be less than 15 in./lbs.
  - If you cannot eliminate the binding, there must be an obstruction inside of the module. In this case, disassemble and inspect the module, eliminate the obstruction, and then reassemble the module ensuring that all parts are installed properly.

- F-11 NOTE:** When the pump is not running, the air inlet tube (69) should be open. When the pump is running, the centrifugal switch (39) should pull away from the lever (41) causing the lever seal (43) to close the air inlet tube (69) (see Figures 5-3 and 5-4).

Ensure that the anti-suck back mechanism is operating correctly as follows:

- Check to see if there is a gap between the lever seal (43) and the end of the air inlet tube (69). If there is not a gap while the pump is at rest, it means that the lever (41) is bent, the spring (42) is out of position, or the centrifugal switch (39) is malfunctioning. Remedy the problem before proceeding (see Figures 5-3 and 5-4).
  - Check if the anti-suck back mechanism will close the air inlet tube (69) as follows:
    - Push the split halves of the centrifugal switch (39) until they are tight against the coupling (37). (See Figure 5-3.)
    - While keeping the split halves of the switch (39) against the coupling (37), check if the lever seal (43) is sealing the opening in the air inlet tube (69) (see Figure 5-4).
    - If the lever seal (43) is not properly sealing the tube (69), see Symptom 3h of the troubleshooting chart (Table 6-1) for recommended corrective action.
  - Make sure that the air inlet tube (69) is pushed back into the module until it is seated firmly. When the air inlet tube (69) is installed properly, the retainer disk (71) fits against the front end plate (44) (see Figure 5-4).
- F-12** It is easiest to guide the module into alignment with the coupling housing (11) when the coupling housing/motor assembly is in the vertical position (see Figure 5-23). Proceed as follows:
- Set the coupling housing/motor assembly back onto its motor end and secure the assembly in this vertical position.
  - Place the main housing seal (13) onto the coupling housing flange (see Figure 5-2).
  - Keeping the module vertical, guide the module end that has the coupling (37) down into the coupling housing (11). The prongs on the module coupling (37) fit into the mating slots in the elastic element (36); the elastic element is located on the motor shaft in the coupling housing (11). Look through the opening in the bottom of the coupling housing (11) to align the mating prongs and slots properly (see Figure 5-23).
  - Use the screws and washers to attach the module to the coupling housing (11) (see Figure 5-2).
  - Return the assembly to the horizontal position.

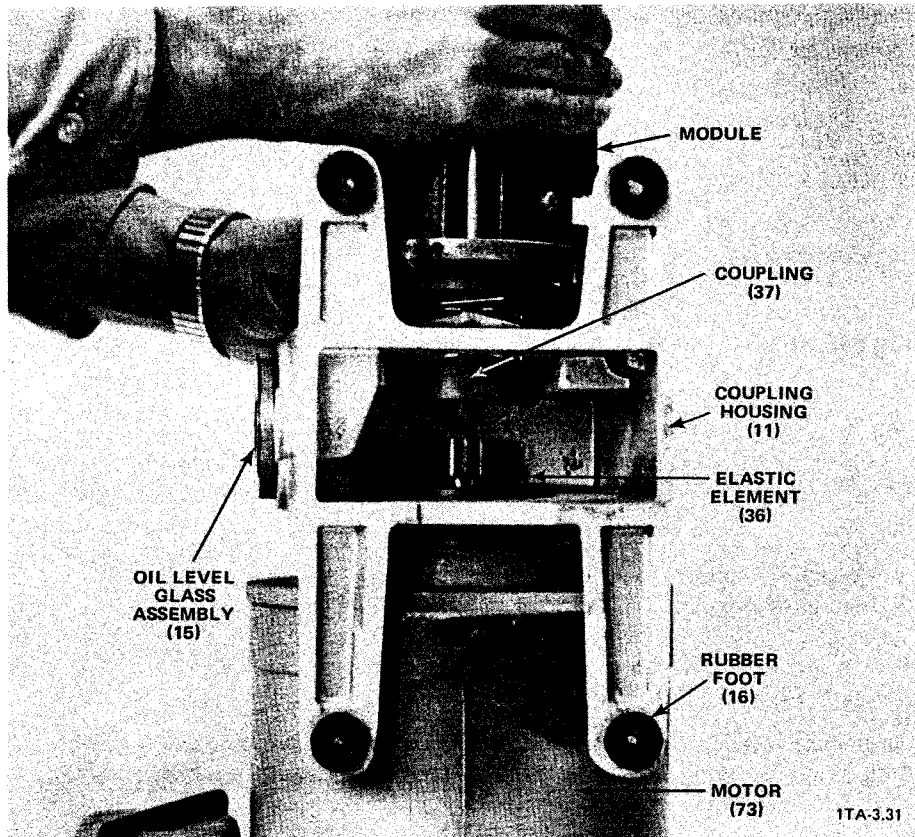

**NOTE:** This view is looking toward the opening in the bottom of the coupling housing (11). The coupling housing/motor assembly is resting on its motor end. The assembly is vertical.

**NOTE:** See Figure 5-15 for a photograph of the D30A/D60A/D90A coupling (37) and coupling ring (36).

Figure 5-23. Reassembling the Module to the Coupling Housing (D4A Pump Model Shown).

**F-13 CAUTION:** DO NOT SCRATCH, NICK, OR TEAR THE VALVE DISK (67) WHEN INSERTING IT INTO THE PUMP CYLINDER.

Using a large pair of long nose pliers, insert the valve disk (67) and attached brass piston (68) into the intake portion of the high vacuum pump cylinder (55) (see Figures 5-3 and -11).

**F-14** Repeat Steps B-8, B-7, B-6, B-5, B-4, and B-2, except assemble rather than disassemble.

**CAUTION:** OVERTIGHTENING THE OIL CASING ONTO THE COUPLING HOUSING COULD DAMAGE THE FLAT GASKET (13) AND CAUSE AN OIL LEAK.

Use the following torque when tightening the oil casing onto the coupling housing:

| Pump Model         | Torque             |
|--------------------|--------------------|
| D2A & D4A          | 4 Nm (3.0 ft-lb)   |
| D8A & D16A         | 7 Nm (5.2 ft-lb)   |
| D30A, D60A, & D90A | 15 Nm (11.1 ft-lb) |

**F-15** Fill the pump with the proper pump fluid (see Section 5-A-1) as follows (see Figure 1-1).

- Using an 8-mm allen wrench, screw a plug screw (8) with flat gasket (9) into each oil drain port.
- Pour the required amount of pump fluid into the exhaust port (6) or into one of the oil fill ports. The required amount of pump fluid for each pump model is listed in Table 4-1.
- Using an 8-mm allen wrench, screw a plug screw (8) with flat gasket (9) into each oil fill port.

**F-16 NOTE:** The O-ring on the centering rings must be clean to avoid leaks.

Use the KF clamp rings to connect the intake tube (1) and exhaust port (6) of the pump to your system.

**F-17** Change the pump fluid after a 100-hour break-in period of pump operation (see Section 4-3-2).



## SECTION 6

### TROUBLESHOOTING

**WARNING:** BEFORE REPAIRING THE PUMP, BE SURE TO READ ALL WARNINGS AND CAUTIONS IN SECTION 5-A AND AT THE BEGINNING OF SECTION 5-B.

The design of the TRIVAC rotary vane pumps allows for easy repair. Most corrective maintenance problems can be resolved quickly by using Table 6-1.

For repairs beyond the scope of this manual, contact your nearest Leybold Sales Office for the location of your nearest service center.

Table 6-1 contains the instructions for troubleshooting your pump if a malfunction occurs. To use the table, first observe the symptom, then locate the trouble area and perform the recommended corrective action. If disassembly of a component is necessary to perform the corrective action, refer to the steps listed in the "Repair Steps" column of Table 6-1. If the Table recommends cleaning, use the general cleaning instructions in Section 5-E, in addition to any specific "Repair Steps" recommended.

#### CONTENTS

| Symptom  | Page     |
|--|----------|
| 1. The lubricating fluid is milky white or dark and the pump fails to reach its ultimate pressure and runs hot (Condensation in Lubricating Fluid) . . . . . | 44       |
| 2. The lubricating fluid has an unusual color, is very dark, dirty, turbid, or contains flakes (Contamination of the Lubricating Fluid) . . . . .            | 44       |
| 3. The pump will not achieve its ultimate pressure . . . . .   | 45,46,47 |
| 4. The evacuated vessel or system is vented to atmosphere pressure after pump shutdown . . . . .   | 47, 48   |
| 5. The pump is excessively noisy . . . . .   | 48       |
| 6. Excessive smoke or oil mist in exhaust stream . . . . .   | 49       |
| 7. Lubricating fluid is ejected out of the intake tube . . . . .   | 49       |
| 8. Excessive lubricating fluid is consumed . . . . .   | 49, 50   |
| 9. Lubricating fluid is leaking from the top of the oil casing . . . . .   | 50       |
| 10. Exhaust gas is leaking from the top of the oil casing . . . . .  | 50       |
| 11. The pump will not start . . . . .  | 50, 51   |
| 12. The pump will not achieve its rated pumping speed . . . . .  | 52       |
| 13. Lubricating fluid or oil is found in the vacuum line or in the vessel or system being evacuated . . . . .  | 53       |
| 14. The pump is running hot (greater than 95°C or 200°F) . . . . .   | 53       |

TABLE 6-1. TROUBLESHOOTING CHART

| Symptoms  | Trouble Area  | Probable Cause  | Recommended Corrective Action  | Repair Steps*   |
|---|---|---|--|-----------------|
| 1. The lubricating fluid is milky white or dark and the pump fails to reach its ultimate pressure and runs hot. | Condensation in lubricating fluid.                              | Gas ballast valve (17) is closed.                               | Run pump with intake tube (1) closed off and gas ballast valve (17) open until vapors are expelled.  | Sec. 4-2        |
|   |   | Gas ballast valve (17) is clogged.                              | +Clean gas ballast valve (17).   | B-5, D-1, & F-4 |
|   |   |   | Install new spring (25), flat gasket (24), and nonreturn valve (23), or valve (19) or valve plate (32) as necessary.   | B-5, D-1, & F-4 |
|   |   | Pump temperature is low.  | Run pump with gas ballast valve (17) open until pump is warm.  | Sec. 4-1-2      |
|   |   |   | Insulate oil casing (12).  |                 |
| Vapor in gas being pumped exceeds pump tolerance.   | Add condensate trap to intake tube (1) and/or exhaust port (6). | B-1 & Sec. 3-3  |  |                 |
| 2. The lubricating fluid has an unusual color, is very dark, dirty, turbid, or contains flakes.                 | Contamination of the pump fluid.                                | Process is dirty.   | Change lubricating fluid.  | Sec. 4-3-2      |
|   |   |   | Add OF-3000 or OF-1000 to purify fluid and prevent reoccurrence of problem.  |                 |
|   |   |   | Add AS dust separator, IF or FS inlet filter, adsorption trap, AK condensate trap, or MF molecular filter to intake tube (1) to prevent reoccurrence of problem. | B-1 & Sec. 3-3  |
|   |   |   | <b>For D2A, D4A, D8A &amp; D16A pump models only, replace oil filter (35).</b>   | B-5 & B-6       |
|   | Pump fluid has broken down.                                     | Wrong pump fluid is being used.                                 | +Clean pump and charge it with the recommended pump fluid.   | Sec. 4-3-2      |
|   |   | Pump ran low on pump fluid.                                     | +Clean pump and charge it with the recommended pump fluid.   | Sec. 4-3-2      |
|   |   | Large vacuum leak.  | Repair leak, +clean pump and change pump fluid.  | Sec. 4-3-2      |
| Pump is running continuously above 112 Torr.  |   | +Clean pump, change pump fluid, and run pump at lower pressure. | Sec. 4-3-2   |                 |

\*This column contains the disassembly steps required to perform the corrective action. Some critical assembly steps are also listed. If the section is not specified, the steps are located in Section 5.

+Use the general cleaning instructions at the beginning of Section 5-E.

TABLE 6-1. TROUBLESHOOTING CHART (Continued)

| Symptoms  | Trouble Area                                       | Probable Cause  | Recommended Corrective Action   | Repair Steps*                   |
|---|--|---|---|---------------------------------|
| 3. The pump will not achieve its ultimate pressure. | a. Gas ballast valve (17)                          | Valve (17) is open.   | Close valve (17) unless condensation is a problem.  | Sec. 2-3-1                      |
|   |  | Cap (18) is worn.   | Install new cap (18).   | D-1a                            |
|   |  | The O-ring (27) on the end of the gas ballast tube (27) is worn.                              | Install new O-ring (27).  | B-5, D-1c, and E-9              |
|   | b. Vacuum line connection                          | Vacuum line is connected to exhaust port (6).   | Connect vacuum line to intake tube (1).   | Sec. 3-3, Steps 3 & 4           |
|   | c. Exhaust connection line                         | Line diameter is smaller than exhaust port (6) diameter.                                      | Install larger diameter connection line.  | Sec. 3-3, Step 4                |
|   | d. Vacuum line or evacuated vessel                 | Vacuum line or vessel contains leak.  | Repair leak or +clean O-ring if dirty.  |                                 |
|   | e. Dirt trap (2) on intake tube (1)                | Trap (2) is obstructed with dirt.   | +Clean dirt trap (2).   | B-1 and B-2                     |
|   | f. Lubricating fluid                               | Fluid is contaminated resulting in poor sealing qualities and excessive wear on seals.        | See Symptoms 1 and 2.   |                                 |
|   |  | Wrong lubricating fluid is being used.  | Flush out pump and add correct lubricating fluid.   | Sec. 4-3-2                      |
|   | g. Module contains insufficient lubricating fluid. | Pump fluid level is too low.  | Add lubricating fluid to pump.  | Sec. 4-3-1                      |
|   |  | Oil nozzle (56) is clogged.   | +Clean oil nozzle (56) and change lubricating fluid.  | B-1 thru B-7, E-3c & Sec. 4-3-2 |
|   |  | Pump is running continuously at 187 or more Torr.   | Slowly pour some lubricating fluid into intake tube (1) and run pump at lower pressure.   | B-1 and Sec. 4-2<br>CAUTION     |
|   | h. Anti-suck back assembly. Also See Symptom 5g.   | The coupling (37) is too tight against the retainer ring (40) or the centrifugal switch (39). | Loosen the coupling setscrew, pull the coupling (37) away from the centrifugal switch (39) or retainer ring (40) until the switch (39) has enough space to function properly, and then tighten the coupling setscrew. | B-1 thru B-9, F-11 & F-12       |

\*This column contains the **disassembly** steps required to perform the corrective action. Some critical **assembly** steps are also listed. If the section is not specified, the steps are located in Section 5.

+Use the general cleaning instructions at the beginning of Section 5-E.

TABLE 6-1. TROUBLESHOOTING CHART (Continued)

| Symptoms  | Trouble Area  | Probable Cause   | Recommended Corrective Action  | Repair Steps*  |
|---|---|--|--|--|
| 3. The pump will not achieve its ultimate pressure (cont'd.). | h. Anti-suck back assembly (cont'd.)  | Centrifugal switch (39) is malfunctioning.                                       | Install new centrifugal switch (39).   | B-1 thru C-5, F-9, F-11 & F-12                                     |
|   |   | Centrifugal switch (39)/lever (41)/spring (42) assembly is excessively dirty.    | +Clean assembly (39)/41/42).   | B-1 thru C-6, F-9, F-11, & F-12                                    |
|   |   | Lever seal (43) is worn.   | Reverse seal (43) or install new seal.   | B-1 thru B-7, & D-7  |
|   |   | Level (41) is bent.  | Straighten lever (41) or install new lever.  | B-1 thru C-6, F-9, F-11, & F-12                                    |
|   |   | The spring (42) is not sitting properly in its hole in the front end plate (44). | Reinstall the spring (42) in its hole.   | B-1 thru C-6, F-9, F-11, & F-12                                    |
|   |   | The O-ring (70) on HV-pump-cylinder end of the air inlet tube (69) is worn.      | Install new O-ring (70).   | B-1 thru C-7, C-14, D-2, E-9, F-7, F-9, F-11, & F-12               |
|   | i. Radial shaft seal (45) is worn.  | Worn seal (45) is allowing venting of module.                                    | Install new seal (45). Inspect the shaft where it rides in the seal for wear. Install new shaft, if necessary. | See worn seal in Symptom 8b. If replacing shaft, do B-1 thru F-17. |
|   | j. Vane (49/53) is stuck in rotor (48/54) slot.   | Dirt has accumulated in rotor slot.  | +Clean rotor slots and change lubricating fluid.   | B-1 thru F-17  |
|   |   | Vanes are installed with chamfered edge out.                                     | Clean vane slots and install vane with chamfered edge facing center of rotor.                                  | B-1 thru F-17  |
|   | k. Vanes (49/53) rotors (48/54), pump cylinders (46/55), shaft, inside surface of plates (52/60/44), or bronze bushing in plates (60/44/52) | One or more of these parts contain gouging or wear.                              | Replace worn part with new part.   | B-1 thru F-17  |

\*This column contains the disassembly steps required to perform the corrective action. Some critical assembly steps are also listed. If the section is not specified, the steps are located in Section 5.

+Use the general cleaning instructions at the beginning of Section 5-E.

TABLE 6-1. TROUBLESHOOTING CHART (Continued)

| Symptoms   | Trouble Area                                 | Probable Cause  | Recommended Corrective Action  | Repair Steps*                  |
|--|--|---|--|--------------------------------|
| 3. The pump will not achieve its ultimate pressure (cont'd.).                            | l. Motor (73)                                | Motor is rotating in wrong direction.   | Interchange line ends.   | F-1a                           |
|  |  |   | Check rotational lock bearing.   | D-13 & F-1b                    |
|  |  | Motor malfunction   | Contact motor manufacturer's service center.   | D-13 & F-1                     |
|  | m. Module O-rings (47) are dirty or damaged. | Dirty or damaged O-rings (47) are allowing venting of module.                         | Install new O-rings (47).  | B-1 thru F-17                  |
|  | n. Intake tube.                              | O-ring (5) is allowing venting of module.   | Install new O-ring (5).  | B-1, B-2, B-4, & D-4           |
|  |  | Sealing surface on bottom of tube is scratched.                                       | Smooth scratches with jeweler's rouge.   | B-1, B-2, & B-4                |
| o. For D4A, D16A, D60A, and D90A pump models only—valve plate (58)                       | Valve plate (58) is dirty or worn.           | + Clean or replace valve plate.   | B-1 thru B-7 & D-11  |                                |
| 4. The evacuated vessel or system is vented to atmospheric pressure after pump shutdown. | a. Vacuum line or evacuated vessel           | Vacuum line or vessel contains leak.  | Repair leak or + clean O-ring if dirty.  |                                |
|  | b. Anti-suck back valve assembly             | *Valve disk (67) is worn or dirty.  | Remove old disk (67) and install new one or clean old disk.  | B-1 thru B-7, Fig. 5-13, & D-5 |
|  |  | Valve disk (67) and piston (68) are stuck in place in high vacuum pump cylinder (55). | + Clean disk and piston or install new ones.<br>+ Clean intake tube portion of high vacuum pump cylinder (55). | B-1 thru B-7, C-1 & D-5        |

\*This column contains the **disassembly** steps required to perform the corrective action. Some critical **assembly** steps are also listed. If the section is not specified, the steps are located in Section 5.

+ Use the general cleaning instructions at the beginning of Section 5-E.

TABLE 6-1. TROUBLESHOOTING CHART (Continued)

| Symptoms   | Trouble Area   | Probable Cause   | Recommended Corrective Action  | Repair Steps*                             |
|--|--|--|--|---|
| 4. The evacuated vessel or system is vented to atmospheric pressure after pump shutdown (cont'd.). | b. Anti-suck back valve assembly (cont'd.).                      | Centrifugal switch (39)/ lever (41)/spring (42) assembly is excessively dirty.   | + Clean assembly (39/41/42).   | B-1 thru C-6, F-9, F-11, & F-12           |
|  |  | Air inlet tube (69) is clogged.  | + Clean air inlet tube (69).   | B-1 thru C-7, C-14, F-7, F-9, F-11 & F-12 |
|  |  | Centrifugal switch (39) is malfunctioning.   | Install new centrifugal switch (39).   | B-1 thru C-5, F-9, F-11, & F-12           |
|  |  | Lever (41) is bent.  | Straighten or install new lever (41).  | B-1 thru C-6, F-9, F-11, & F-12           |
| 5. The pump is excessively noisy.  | a. Intake or exhaust connecting lines                            | Line contains restriction  | Clear line.  | B-1                                       |
|  | b. Slap noise heard (oil slap) when attaining ultimate pressure. | The silencing hole is the tiny hole in the side of the gas ballast valve (17) stem just <b>below</b> the bolting flange. | + Use a fine wire to clear any dirt from the silencing hole. <b>DO NOT ENLARGE THE HOLE.</b>   | B-5                                       |
|  | c. Coupling (37) and/or elastic element (36)                     | Coupling and/or element is worn.   | Install new element and/or coupling.   | See Symptom 11a.                          |
|  | d. Disk (61)   | Disk is bent.  | Straighten disk or install new disk.   | B-1 thru B-8                              |
|  | e. Module  | Module contains insufficient lubricating fluid.  | See Symptom 3g.  | See Symptom 3g.                           |
|  | f. Module bushing  | Lubricating holes in end plates are clogged.   | Clear holes so pump fluid can lubricate the shaft bushing.   | E-3                                       |
|  | g. Shipping wedge  | The shipping wedge was not removed.  | Remove shipping wedge. NOTE: Running the pump with the shipping wedge installed can result in damage to the anti-suckback mechanism. | Sec. 3-3, Step 2. Symptom 4b.             |

\*This column contains the disassembly steps required to perform the corrective action. Some critical assembly steps are also listed. If the section is not specified, the steps are located in Section 5.

+ Use the general cleaning instructions at the beginning of Section 5-E.



TABLE 6-1. TROUBLES SHOOTING CHART (Continued)

| Symptoms   | Trouble Area  | Probable Cause   | Recommended Corrective Action  | Repair Steps*   |
|--|---|--|--|---|
| 6. Excessive smoke or oil mist in exhaust stream.                                  | a. Fluid level in sight glass (15) is high.                     | Pump is filled with lubricating fluid beyond its capacity.   | Drain excess lubricating fluid.  | Sec. 4-3-1  |
|  | b. Negative pressure exhaust system (only if one is connected). | Negative pressure is too high.   | Adjust negative pressure exhaust system.   | Sec. 3-3, Step 5                                      |
|  | c. Oil filter (35)  | Filter is clogged.   | + Clean filter or install new filter.  | B-5 & B-6   |
|  | d. Pump pressure  | Pump is running continuously at greater than 112 Torr.   | Modify system to run at lower pressure or use larger pump model.   | Sec. 4-2<br>CAUTION                                   |
|  | e. Gas ballast valve (17)                                       | Valve (17) is open.  | Close valve (17) or install SE smoke eliminator or AF exhaust filter with oil return line.                 | Sec. 2-3  |
| 7. Lubricating fluid is ejected out of the intake tube (1). (Also see Symptom 13.) | Motor (73)  | Motor is rotating in wrong direction.  | Interchange the line ends.   | F-1a  |
|  |   |  | Check rotational lock bearing.   | D-9 & F-1b  |
| 8. Excessive lubricating fluid is consumed. (Also see symptoms 6 and 9.)           | a. Oil filter (35)  | Filter is clogged.   | + Clean filter or install new filter.  | B-5 & B-6   |
|  | b. Oil leak   | Flat gasket (9) on plug screw (8) is worn.   | Install new flat gasket (9).   | B-3, D-6, & F-15                                      |
|  |   | Main seal (13) between oil casing (12) and coupling housing (11) is worn.  | Replace seal (13).   | B-1 thru B-10, F-12, F-14 thru F-16                   |
|  |   | Front end plate radial shaft seal (45) is worn.  | Install new seal and check if the exhaust line is too narrow or if an exhaust filter or screen is clogged. | B-1 thru C-6, D-10, F-6k, F-9, F-11, & F-12           |
|  |   | Rear end plate radial shaft seal (45) is worn.   | Install new seal.  | B-1 thru C-1, C-9, C-10, D-8, F-3, F-6g, F-10, & F-12 |
|  | Inert gas pressure in purge line of modified pumps is too high. | Reduce inert gas pressure to below 3 psig for an oil casing purge & below 2 psig for an inert gas connection to the gas ballast valve. | Sec. 3-3   |   |

\*This column contains the **disassembly** steps required to perform the corrective action. Some critical **assembly** steps are also listed. If the section is not specified, the steps are located in Section 5.

+ Use the general cleaning instructions at the beginning of Section 5-E.

TABLE 6-1. TROUBLESHOOTING CHART (Continued)

| Symptoms   | Trouble Area  | Probable Cause  | Recommended Corrective Action   | Repair Steps*  |
|--|---|---|---|--|
| 8. Excessive lubricating fluid is consumed. (Also see symptoms 6 and 9) (cont'd.). | c. Gas ballast valve (17)                               | Valve (17) is open.   | Close valve (17) or use AF exhaust filter with oil return line.                                 | Sec. 2-3-1   |
|  | d. Lubricating fluid is ejected out of intake tube (1). | Motor is rotating in wrong direction.   | Interchange the line ends.  | F-1a   |
|  |   |   | Check rotational lock bearing.  | F-1b   |
| 9. Lubricating fluid is leaking from the top of the oil casing (12).               | Gas ballast valve (17)                                  | Flat gasket (4) is worn.  | Install new flat gasket (4).  | B-5  |
|  |   | Oil casing (12) is scratched below valve (17) flange.                               | Install new oil casing (12).  | B-1 thru B-7   |
| 10. Exhaust gas is leaking from the top of the oil casing (12).                    | a. Intake tube (1) or gas ballast valve (17)            | Flat gasket (4) is worn.  | Install new flat gasket (4).  | B-1, B-2, & B-4 or B-5   |
|  |   | Oil casing (12) is scratched below tube (1) or valve (17).                          | Install new oil casing (12).  | B-1 thru B-7   |
| 11. The pump will not start.   | a. Coupling (37) and/or elastic element (36)            | Coupling and/or element is worn or improperly installed.                            | Properly install new coupling and/or elastic element.   | ++   |
|  | b. Shaft is seized in bushing.                          | Lubricating fluid is contaminated.  | If needed, replace shaft, end plates (44/60), and/or center bearing (52). See Symptoms 1 and 2. | If needed B-1 thru F-17  |
|  |   | Hole in rear-end plate (60) bronze bushing is clogged.                              | +Clean hole. If necessary, replace shaft and/or end plate (60).                                 | B-1 thru B-8; if needed B-9 thru F-17  |
|  |   | Hole running from bottom edge of front end plate (44) to bronze bushing is clogged. | +Clean hole. If necessary, replace shaft and/or end plate (44).                                 | B-1 thru B-8; if needed B-9 thru C-7, C-9, C-13, F-9, F-10, F-11, & F-12; or B-9 thru F-17 |

\*This column contains the disassembly steps required to perform the corrective action. Some critical assembly steps are also listed. If the section is not specified, the steps are located in Section 5.

+Use the general cleaning instructions at the beginning of Section 5-E.

++D-13, D-14 and F-12, except set pump on its oil-casing (12) end and lower the motor into alignment. If the module coupling is worn, do B-1 thru C-2, F-9, & F-12.

**TABLE 6-1. TROUBLESHOOTING CHART (Continued)**

| Symptoms  | Trouble Area   | Probable Cause  | Recommended Corrective Action  | Repair Steps*  |  |
|---|--|---|--|--|--|
| 11. The pump will not start. (cont'd.).                     | c. Module is not vented.   | Valve disk (67) and piston (68) are stuck in place in high vacuum pump cylinder (55).   | + Clean disk and piston or install new ones.<br>+ Clean intake tube portion of high vacuum pump cylinder (55). | B-1 thru B-7, C-1 & D-5  |  |
|   |  | <b>For D30A, D60A, and D90A pump models only</b> , small hole in high vacuum pump cylinder (55) just below piston(68) is clogged. | + Clean this small hole.   | B-1 thru B-7, C-1, E-3d; if needed C-2 thru C-7, C-14, F-7, F-9, F-11, & F-12  |  |
|   |  | Centrifugal switch (39)/lever (41)/spring (42) assembly is excessively dirty.   | + Clean assembly (39/41/42).   | B-1 thru C-6, F-9, F-11, & F-12  |  |
|   |  | Air inlet tube (69) is clogged.   | + Clean air inlet tube (69).   | B-1 thru C-7, C-14, F-7, F-9, F-11, & F-12                                     |  |
|   |  | Centrifugal switch (39) is malfunctioning.  | Install new centrifugal switch (39).   | B-1 thru C-5, F-9, F-11, & F-12  |  |
|   |  | Lever (41) is bent.   | Straighten or install new lever (41).  | B-1 thru C-6, F-9, F-11, & F-12  |  |
|   |  | Spring (42) is not sitting properly in its hole in the front end plate (44).  | Reinstall the spring (42) in its hole.   | B-1 thru C-6, F-9, F-11, & F-12  |  |
|   | d. Friction occurs between the rotors (48/54) or vanes (49/53), and the module housing (44/46/52/55/60). | Module is not aligned properly.   | Align module.  | B-1 thru B-10, F-10, & F-12  |  |
|   | e. Pump fluid is too thick.  |   | Room is too cold. (The minimum ambient temperature for easy startup is 50° F.)                                 | Start pump at atmospheric pressure before connecting it to your vacuum system. |  |
|   |  |   |  | Heat oil casing (12)   |  |
| Drain pump fluid, heat it, and refill pump with warm fluid. |  |   |  |  |  |

\*This column contains the **disassembly** steps required to perform the corrective action. Some critical **assembly** steps are also listed. If the section is not specified, the steps are located in Section 5.

+ Use the general cleaning instructions at the beginning of Section 5-E.

TABLE 6-1. TROUBLESHOOTING CHART (Continued)

| Symptoms  | Trouble Area  | Probable Cause   | Recommended Corrective Action                                | Repair Steps*                                   |
|---|---|--|--|---|
| 12. The pump will not achieve its rated pumping speed. (See Section 1 of the Leybold-Heraeus Catalog for pumping speed curves.) | a. Lubricating fluid  | Pump is cold.  | Run pump for 1 hour while it warms to operating temperature. | Sec. 4-1-2                                      |
|   |   | Fluid is dirty.  | See Symptoms 1 and 2.  |   |
|   | b. Vacuum line valve  | Vacuum line valve is partially closed.                   | Open vacuum line valve.                                      |   |
|   | c. Dirt trap (2) on intake tube (1)   | Trap (2) is obstructed with dirt.                        | +Clean dirt trap (2).  | B-1 and B-2                                     |
|   | d. Exhaust or vacuum line   | Exhaust or intake filter accessory is dirty.             | Clean or install new filtering element.                      | B-1 & Sec. 3-3                                  |
|   | e. Exhaust or vacuum line connection  | Exhaust or intake line diameter is too small.            | Install larger diameter connection line.                     | B-1 & Sec. 3-3, Steps 3 & 4                     |
|   | f. Coupling (37) and/or elastic element (36)  | Coupling and/or element is worn or improperly installed. | Properly install new element and/or coupling.                | See Symptom 11a.                                |
|   | g. Exhaust holes in second stage pump cylinder (46) or opening in center bearing (52)           | Holes or opening is blocked.                             | +Clean holes or opening.                                     | B-1 thru B-7, & D-12. If needed, D-13 thru F-17 |
|   | h. Anti-suck back assembly  | See Symptom 3h.  | See Symptom 3h.  |   |
|   | i. Friction between the rotors (48/54) or vanes (49/53) and the module housing (44/46/52/55/60) | Module is not aligned properly.                          | Align module.  | B-1 thru B-10, F-10, & F-12                     |
|   |   | Oil nozzle (56) is clogged.                              | +Clean nozzle (56).  | B-1 thru B-7 & E-3c                             |
| j. Inside of module housing (44/46/52/55/60)  | Dirt buildup is restraining rotation speed.   | +Clean inside of module and change lubricating fluid.    | B-1 thru F-17  |   |
| k. Motor  | Malfunction   | Contact motor manufacturer's service center.             | D-13 & F-1   |   |

\*This column contains the disassembly steps required to perform the corrective action. Some critical assembly steps are also listed. If the section is not specified, the steps are located in Section 5.

+Use the general cleaning instructions at the beginning of Section 5-E.

TABLE 6-1. TROUBLESHOOTING CHART (Continued)

| Symptoms  | Trouble Area                                       | Probable Cause                                       | Recommended Corrective Action                                       | Repair Steps*  |
|---|--|--|---|----------------|
| 13. Lubricating fluid or oil is found in the vacuum line or in the vessel or system being evacuated (Also see Symptom 7). | a. Vapors are back-streaming into the vacuum line. | Lubricating fluid is contaminated.                   | See Symptoms 1 & 2.   |                |
|   |  | Vapor pressure of lubricating fluid is insufficient. | Replace used fluid with HE-200 lubricating fluid.                   | Sec. 4-3-2     |
|   |  |  | Install an RST, FA or adsorption trap in the inlet line.            | B-1 & Sec. 3-3 |
|   |  | Pump fluid suckback during shutdown.                 | See Symptom 4b.   |                |
| Install SECUVAC® valve or venting device.   |  |  |   |                |
| 14. The pump is running hot (greater than 95°C or 200°F)  |  |  | See Symptoms 1, 2, 3a through 3i, 11b, 11d, 12e, 12i, 12j, and 12k. |                |

\*This column contains the **disassembly** steps required to perform the corrective action. Some critical **assembly** steps are also listed. If the section is not specified, the steps are located in Section 5.

## SECTION 7

### PARTS LIST

**Table 7-1** contains information for ordering modules, gasket sets, and repair kits. **Table 7-2** is a complete list of spare parts.

**Use Figures 7-1 and 7-2** to help identify the part that you need. The numbers called out in the figures correspond to the position number listed for each part in the first column of **Table 7-2**. For example, the first column on **Page 58** lists "1" for the intake tube. One **Figure 7-1**, the number "1" is pointing to the photograph of the intake tube.

The second series of six columns indicates which pump model uses the part and how many each pump requires. For example, in **Table 7-2** the number "1" under the "D2A" column for Position No. 1 indicates that one intake tube (Part No. 433 60 118) is required for the D2A pump model. Be sure to specify the model and Serial Number of your pump when ordering spare parts.

#### CONTENTS

| Title  | Page       |
|--|------------|
| Disassembled Pump (D2A Pump Model Shown) (Figure 7-1) .....                            | 56         |
| Module .....   | 57         |
| Universal Gasket Set .....   | 57         |
| Module Repair Kit .....  | 57         |
| Anti-Suckback Modification Kit .....   | 57         |
| Intake Tube Assembly .....   | 58         |
| Exhaust Port Assembly .....  | 58, 59     |
| Pump Housing Assembly .....  | 59, 60     |
| Gas Ballast Valve Assembly (Includes Oil Filter) .....                                 | 60, 61     |
| Coupling Assembly .....  | 61, 62     |
| Module Centrifugal Switch and Retainer Ring .....                                      | 62         |
| Lever Assembly .....   | 62         |
| Second Stage Assembly (Includes Center Bearing and Exhaust Valve Plate and Stop) ..... | 62, 63, 64 |
| High Vacuum Stage Assembly .....   | 64, 65, 66 |
| Module Studs and Pins .....  | 66         |
| Anti-Suck Back Assembly .....  | 67         |
| Motors .....   | 68, 69, 70 |
| Oil Sight Gauge Assembly .....   | 67         |

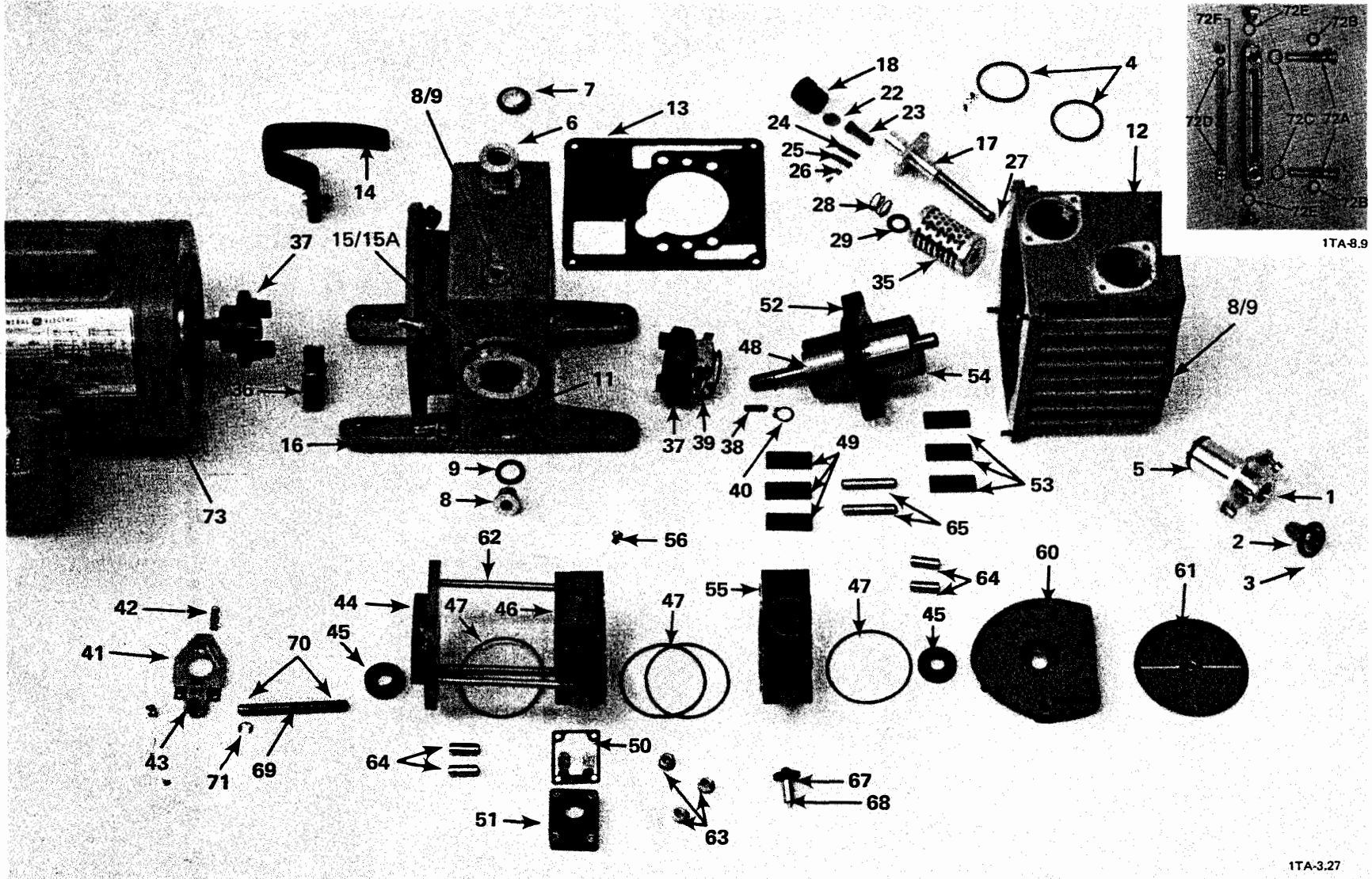

Figure 7-1. Disassembled Pump (D2A Pump Model Shown)

NOTE: The numbers on this figure correspond to the Position No. listed for each part in Table 7-2, beginning on page 58.



TABLE 7-1 - SPARE MODULL, GASKET SETS, AND REPAIR KITS

TRIVAC "A" Manual, Edition 1

| Number Required Per Unit |     |     |      |      |               | Part Name                        | Catalog No. | Remarks   |
|--------------------------|-----|-----|------|------|---------------|----------------------------------|-------------|---|
| Pump Model               |     |     |      |      |               |                                  |             |   |
| D2A                      | D4A | D8A | D16A | D30A | D60A/<br>D90A |                                  |             |   |
| 1                        |     |     |      |      |               | Module, standard                 | 899510      | The module is made up of all parts listed with an "*" beside its catalog number in Table 7-2.   |
| 1                        |     |     |      |      |               | Module, corrosive series         | 10166C      |   |
|                          | 1   |     |      |      |               | Module, standard                 | 899511      | For extreme-corrosive service pump modules, contact the main office.  |
|                          |     |     |      |      |               | Module, corrosive series         | 10167C      |   |
|                          |     | 1   |      |      |               | Module, standard                 | 899512      |   |
|                          |     | 1   |      |      |               | Module, corrosive series         | 899512      |   |
|                          |     |     | 1    |      |               | Module, standard                 | 899513      |   |
|                          |     |     | 1    |      |               | Module, corrosive series         | 899513      |   |
|                          |     |     |      | 1    |               | Module, standard                 | 899514      |   |
|                          |     |     |      | 1    |               | Module, corrosive series         | 10170C      |   |
|                          |     |     |      |      | 1             | Module, standard                 | 899515      |   |
|                          |     |     |      |      | 1             | Module, corrosive series         | 10171C      |   |
| 1                        | 1   |     |      |      |               | Universal gasket set             | 19102-B2    | The gasket set is made up of all parts listed with a "++" beside its catalog number in Table 7-2.   |
|                          |     | 1   | 1    |      |               | Universal gasket set             | 19104-B2    |   |
|                          |     |     |      | 1    | 1             | Universal gasket set             | 19106-B2    | The gaskets are Viton; they can be used for standard, corrosive, and extreme-corrosive applications. Buna gasket sets are available on request. |
| 1                        |     |     |      |      |               | Module repair kit                | 10166-K     | The repair kit is made up of all parts listed with a "+ +" or " + " beside its catalog number in Table 7-2.                                     |
|                          | 1   |     |      |      |               | Module repair kit                | 10167-K     |   |
|                          |     | 1   |      |      |               | Module repair kit                | 10168-K     | For corrosive application series pumps, the catalog No. of the kit is the same except the "K" is replaced by "CK".                              |
|                          |     |     | 1    |      |               | Module repair kit                | 10169-K     |   |
|                          |     |     |      | 1    |               | Module repair kit                | 10170-K     |   |
|                          |     |     |      |      | 1             | Module repair kit                | 10171-K     |   |
| 1                        | 1   |     |      |      |               | Oil Filter (demister)            | 390 26 121  | Item 35   |
|                          |     | 1   | 1    |      |               | Oil Filter (demister)            | 390 26 117  | Item 35   |
| 1                        | 1   |     |      |      |               | Anti-suckback modification kit ‡ | 720-24-003  | 120V, 60 Hz   |
| 1                        | 1   |     |      |      |               | Anti-suckback modification kit ‡ | 720-24-002  | 208/240/480V, 50/60 Hz  |
|                          |     | 1   | 1    |      |               | Anti-suckback modification kit ‡ | 720-24-005  | 120V, 60 Hz   |
|                          |     | 1   | 1    |      |               | Anti-suckback modification kit ‡ | 720-24-004  | 208/240/480V, 50/60 Hz  |
|                          |     |     |      | 1    | 1             | Anti-suckback modification kit ‡ | 720-24-001  | 208/240/480V, 50/60 Hz  |

‡ This kit must be installed before pumping toxic, pyrophoric, or hazardous gases. See the supplemental instructions that come with the kits and with the TRIVAC AC pumps for the part numbers of each item in the kit.

TABLE 7-2—COMPLETE LIST OF PARTS

| Position No. on Figs. | Number Required per Unit |     |     |      |      |               | Part Name                     | Catalog No.      | Dimensions (mm) | Material | Remarks   |
|-----------------------|--------------------------|-----|-----|------|------|---------------|-------------------------------|------------------|-----------------|----------|---|
|                       | Pump Model               |     |     |      |      |               |                               |                  |                 |          |   |
|                       | D2A                      | D4A | D8A | D16A | D30A | D60A/<br>D90A |                               |                  |                 |          |   |
| 1                     | 1                        | 1   |     |      |      |               | INTAKE TUBE ASSEMBLY          |                  |                 |          |   |
|                       |                          |     | 1   | 1    |      |               | Intake tube                   | 433 60 118       | KF16            | Al-aly   |   |
|                       |                          |     |     |      | 1    | 1             | Intake tube                   | 433 60 119       | KF25x71         | Al-aly   |   |
|                       |                          |     |     |      |      |               | Intake tube                   | 431 65 116       | KF40x107        | Al-aly   |   |
| 2                     | 1                        | 1   |     |      |      |               | Dirt trap with centering ring | 411 70 122       | KF16            | Steel    |   |
| 2                     |                          |     | 1   | 1    |      |               | Dirt trap & centering ring    | 411 70 206       | KF25            | Steel    |   |
| 2                     |                          |     |     |      | 1    | 1             | Dirt trap with centering ring | 411 70 121       | KF40            | Steel    |   |
| 3                     | 2                        | 2   |     |      |      |               | O-ring                        | 239 70 176++ ✓   | D18x5           | Viton    | One of the O-rings goes on the intake centering ring; the other goes on the exhaust centering ring. |
| 3                     |                          |     | 2   | 2    |      |               | O-ring                        | 239 70 506++ ✓   | D28x5           | Viton    |   |
| 3                     |                          |     |     |      | 2    | 2             | O-ring                        | 239 70 516       | D42x5           | Viton    |   |
| 4                     | 2                        | 2   |     |      |      |               | Flat gasket                   | 238 20 147++ * ✓ | D38x44          | It-200   | One of the flat gaskets fits under the intake tube; the other fits under the gas ballast valve.     |
| 4                     |                          |     | 2   | 2    |      |               | Flat gasket                   | 238 20 156++ * ✓ | D55x63          | It-200   |   |
| 4                     |                          |     |     |      | 2    | 2             | Flat gasket                   | 238 20 158++ * ✓ | D75x84          | It-200   |   |
| 5                     | 1                        | 1   |     |      |      |               | O-ring                        | 239 70 410++ ✓   | D22x3           | Viton    |   |
| 5                     |                          |     | 1   | 1    |      |               | O-ring                        | 239 70 117++ ✓   | D29x3           | Viton    |   |
| 5                     |                          |     |     |      | 1    | 1             | O-ring                        | 239 70 304++ ✓   | D45x3           | Viton    |   |
| 6                     | 1                        | 1   |     |      |      |               | EXHAUST PORT ASSEMBLY         |                  |                 |          |   |
|                       |                          |     |     |      |      |               | Exhaust port                  | 433 60 113       | KF16            | Al-aly   |   |
|                       |                          |     |     |      |      |               | Exhaust port                  | 433 60 117       | KF25x42         | Al-aly   |   |
| 6                     |                          |     |     |      | 1    | 1             | Exhaust port                  | 433 60 115       | KF40x63         | Al-aly   |   |

++Included in universal gasket set and module repair kit (see page 57 of parts list).

\*Included in the standard module (see Page 57).

KF – Leybold quick assembly clamp ring diameter  
 D – diameter  
 Al-aly – aluminum alloy  
 Viton – heat resistant synthetic rubber  
 It-200 – asbestos gasket fiber

| Position No. on Figs. | Number Required per Unit |     |     |      |      |           | Part Name   | Catalog No.     | Dimensions (mm)   | Material  | Remarks                      |
|-----------------------|--------------------------|-----|-----|------|------|-----------|---|-----------------|-------------------|-----------|------------------------------|
|                       | Pump Model               |     |     |      |      |           |   |                 |                   |           |                              |
|                       | D2A                      | D4A | D8A | D16A | D30A | D60A/D90A |   |                 |                   |           |                              |
| 7                     | 1                        | 1   |     |      |      |           | EXHAUST PORT ASSY.<br>(Cont'd.)<br>Centering ring with O-ring | 88346           | KF16              | SS, Viton |                              |
| 7                     |                          |     | 1   | 1    |      |           | Centering ring with O-ring                                    | 88347           | KF25              | SS, Viton |                              |
| 7                     |                          |     |     |      | 1    | 1         | Centering ring with O-ring                                    | 88348           | KF40              | SS, Viton |                              |
| 8                     | 3                        | 4   | 4   | 4    | 4    | 4         | PUMP HOUSING ASSEMBLY<br>Plug screw                           | 201 27 105 ++   | D16x1.5           | Stl       | DIN 908, Isometric, Straight |
| 9                     | 3                        | 4   | 4   | 4    | 4    | 4         | Flat gasket   | 239 55 165 ++   | D22x15.1x2        | Viton     |                              |
| 10                    |                          |     |     |      | 1    | 1         | Eye bolt  | 201 13 101      | M8                | Stl       | See Figure 7-2.              |
| 11                    | 1                        | 1   |     |      |      |           | Coupling housing  | 720 00 001      | 228x140x185       | C Al-aly  |                              |
| 11                    |                          |     | 1   | 1    |      |           | Coupling housing  | 720 00 003      | 265x172.5x216.5   | C Al-aly  |                              |
| 11                    |                          |     |     |      | 1    |           | Coupling housing  | 720 00 019      | 149x242x272.5     | Cast iron |                              |
| 11                    |                          |     |     |      |      | 1         | Coupling housing  | 720 00 021      | 164x242x272.5     | Cast iron |                              |
| 12                    | 1                        |     |     |      |      |           | Oil casing  | 720 00 005      | 127.5x135x162     | C Al-aly  |                              |
| 12                    |                          | 1   |     |      |      |           | Oil casing  | 720 00 007      | 162.5x135x162     | C Al-aly  |                              |
| 12                    |                          |     | 1   |      |      |           | Oil casing  | 720 00 009      | 158x172.5x192.5   | C Al-aly  |                              |
| 12                    |                          |     |     | 1    |      |           | Oil casing  | 720 00 011      | 200.5x172.5x192.5 | C Al-aly  |                              |
| 12                    |                          |     |     |      | 1    |           | Oil casing  | 720 00 015      | 246.5x242x279.5   | Al-aly    |                              |
| 12                    |                          |     |     |      |      | 1         | Oil casing  | 720 00 017      | 321.5x242x279.5   | Al-aly    |                              |
| 13                    | 1                        | 1   |     |      |      |           | Seal  | 238 11 123 ++ * | 136x162x1         | It        |                              |
| 13                    |                          |     | 1   | 1    |      |           | Seal  | 238 11 126 ++ * | 172x190x1         | It        |                              |
| 13                    |                          |     |     |      | 1    | 1         | Seal  | 238 11 142 ++ * | 242x270x1         | Westit    |                              |

++Included in universal gasket set and module repair kit (see page 57 of parts list).

\*Included in the standard module (see Page 57).

SS—Stainless Steel  
 KF—Leybold quick assembly clamp ring diameter  
 D—Diameter  
 Stl—steel  
 Viton—heat resistant synthetic rubber  
 C Al-aly—cast aluminum alloy  
 Al-aly—aluminum alloy  
 Westit—asbestos neoprene with silicone bead  
 It—asbestos gasket fiber  
 Buna-N—synthetic rubber  
 Al—Aluminum

| Position No. on Figs. | Number Required per Unit |     |     |      |      |           | Part Name   | Catalog No.    | Dimensions (mm) | Material      | Remarks  |
|-----------------------|--------------------------|-----|-----|------|------|-----------|---|----------------|-----------------|---------------|--|
|                       | Pump Model               |     |     |      |      |           |   |                |                 |               |  |
|                       | D2A                      | D4A | D8A | D16A | D30A | D60A/D90A |   |                |                 |               |  |
| 14                    | 1                        | 1   |     |      |      |           | PUMP HOUSING ASSY. (Cont'd.)<br>Handle                | 283 02 106     | 100x86x28       | Black plastic |  |
| 14                    |                          |     | 1   | 1    |      |           | Handle  | 283 02 107     | 106x120x32      | Black plastic |  |
| 15                    | 1                        | 1   |     |      |      |           | Oil level glass                                       | 520 40 124     | M50x1.5         | Glass, Viton  | Includes flat gasket (Item 15A)                                      |
| 15                    |                          |     | 1   | 1    | 1    | 1         | Oil level glass                                       | 520 40 125     | M60x2           | Glass, Viton  |  |
| 15A                   | 1                        | 1   |     |      |      |           | Flat gasket   | 239 55 172 ++  | 48x56x2         | Viton         |  |
| 15A                   |                          |     | 1   | 1    | 1    | 1         | Flat gasket   | 239 55 171 ++  | 60x68x2         | Viton         |  |
| 16                    | 4                        | 4   | 4   | 4    |      |           | Rubber foot   | 279 80 308     | D20x16          | Buna-N        |  |
| 16                    |                          |     |     |      | 2    | 2         | Support   | 720-00-068     | 63.5x38         | Stl           | Not shown in Figs.   |
|                       |                          |     |     |      | 4    | 4         | Vibration pad   | 99 274 005     |                 | Buna-S        |  |
|                       | 1                        | 1   |     |      |      |           | GAS BALLAST VALVE ASSEMBLY<br>Gas ballast valve assy. | 720 00 077     |                 |               | This assembly includes Position Numbers 17 thru 27 and 30, 31, & 32. |
|                       |                          |     | 1   | 1    |      |           | Gas ballast valve assy.                               | 720 00 079     |                 |               |  |
|                       |                          |     |     |      | 1    | 1         | Gas ballast valve assy.                               | 720 00 080     |                 |               |  |
| 17                    | 1                        | 1   |     |      |      |           | Gas ballast valve stem                                | ‡              | 43x109          | Al-aly, Stl   |  |
| 17                    |                          |     | 1   | 1    |      |           | Gas ballast valve stem                                | ‡              | 65x113.5        | Al-aly-Stl    |  |
| 17                    |                          |     |     |      | 1    | 1         | Gas ballast valve stem                                | ‡              | 85x85x67        | Al-aly, Stl   |  |
|                       |                          |     |     |      |      |           | Flat gasket   |                |                 |               | See Position No. 4.  |
| 18                    | 1                        | 1   |     |      |      |           | Cap   | 349 75 102     | D22x24          | Buna-N        |  |
| 18                    |                          |     | 1   | ①    | 1    | 1         | Cap   | 349 75 105     | D50x40          | Buna-N        |  |
| 19                    |                          |     | 1   | 1    | 1    | 1         | Valve assembly  | 350 20 158     | D31.7x6         | Thermoplastic | See Fig. 5-10A.  |
| 20                    |                          |     | 1   | 1    | 1    | 1         | O-ring  | 239 70 436 ++  | D27x2.5         | Viton         | See Fig. 5-10A.  |
| 21                    |                          |     | 1   | 1    | 1    | 1         | Retaining washer                                      | 221 49 207     | D19.5x33x0.9    | Steel         | See Fig. 5-10A.  |
| 22                    | 1                        | 1   |     |      |      |           | Stiffening disk                                       | 222 04 104     | D15x3           | Brass         |  |
| 22                    |                          |     | 1   | 1    | 1    | 1         | Stiffening disk                                       | 222 04 107     | D40x0.5         | Bronze        |  |
| 23                    | 1                        | 1   |     |      |      |           | Nonreturn valve                                       | 350 20 126     | D16x26          | Steel         |  |
| 24                    | 1                        | 1   |     |      |      |           | Flat gasket   | 239 73 133 + ‡ | 19x6x1          | Viton         |  |
| 25                    | 1                        | 1   |     |      |      |           | Spring  | 451 74 424 ++  | 19x0.1          | Steel         |  |
| 26                    | 1                        | 1   |     |      |      |           | Strengthening piece                                   | 451 74 425 + ‡ | 6x7x0.1         | Steel         |  |
|                       | 1                        | 1   |     |      |      |           | Pan head screw  | 201 04 129     | M2 x 6          | Steel         | Not shown  |

++ Included in universal gasket set and module repair kit (see page 57 of parts list).

‡ Must be purchased as gas ballast assembly.

Buna-N—synthetic rubber

Stl—steel

Al-aly—aluminum alloy

D—diameter

Viton—heat resistant synthetic rubber

| Position No. on Figs. | Number Required per Unit |     |     |      |      |               | Part Name                            | Catalog No.   | Dimensions (mm) | Material   | Remarks   |
|-----------------------|--------------------------|-----|-----|------|------|---------------|--------------------------------------|---------------|-----------------|------------|---|
|                       | Pump Model               |     |     |      |      |               |                                      |               |                 |            |   |
|                       | D2A                      | D4A | D8A | D16A | D30A | D60A/<br>D90A |                                      |               |                 |            |   |
| 27                    | 1                        | 1   | 1   | 1    |      |               | GAS BALLAST VALVE ASSEMBLY (Cont'd.) |               |                 |            |   |
|                       |                          |     |     |      |      |               |                                      |               |                 |            |   |
| 27                    |                          |     |     |      | 1    | 1             | O-ring                               | 239 70 147++  | D16x2.5         | Viton      |   |
| 28                    | 1                        | 1   |     |      |      |               | Spring (filter)                      | 221 62 144    | D14.5x12x1.25   | Steel      |   |
| 28                    |                          |     | 1   | 1    |      |               | Spring (filter)                      | 221 62 143    | D20x35          | Steel      |   |
| 28                    |                          |     |     |      | 1    | 1             | Spring (filter)                      | 221 62 142    | D25.2x38        | Steel      |   |
| 29                    | 1                        | 1   |     |      |      |               | Flat gasket                          | 239 25 227++  | D18x10x1        | Viton      |   |
| 29                    |                          |     | 1   | 1    |      |               | Flat gasket                          | 239 25 226++  | D30x16x1        | Viton      |   |
| 29                    |                          |     |     |      | 1    | 1             | Flat gasket                          | 239 25 225++  | D30x18x1        | Viton      |   |
| 30                    |                          |     |     |      | 1    | 1             | Retainer ring                        | 231 04 104    | D15x1           | Steel      | See Fig. 5-10B.   |
| 31                    |                          |     |     |      | 1    | 1             | Spring (gas ballast)                 | 221 62 140    | D15x11.5        | Steel      | See Fig. 5-10B.   |
| 32                    |                          |     |     |      | 1    | 1             | Valve plate                          | 401 64 117++  | D14.8x0.2       | Steel      | See Fig. 5-10B.   |
| 33                    |                          |     | 1   | 1    |      |               | Cover                                | 341 01 109    | D48x5           | Steel      | Not shown in Figs.  |
| 34                    |                          |     | 1   | 1    |      |               | Retainer ring                        | 231 03 106    | 17x1            | Steel      | Not shown in Figs.  |
| 35                    | 1                        | 1   |     |      |      |               | Oil filter                           | 390 26 121+   | D36x55          | Stl, fiber |   |
| 35                    |                          |     | 1   | 1    |      |               | Oil filter                           | 390 26 117+   | D42x55          | Stl, fiber |   |
| 35                    |                          |     |     |      | 1    | 1             | Oil separator                        | 411 12 108-A  | D58x90          | Steel      | See Fig. 5-10B.   |
|                       |                          |     |     |      |      |               | Oil filter spring                    |               |                 |            | See position 28   |
| 36                    | 1                        | 1   | 1   | 1    |      |               | COUPLING ASSEMBLY                    |               |                 |            |   |
|                       |                          |     |     |      |      |               |                                      |               |                 |            |   |
| 36                    |                          |     |     |      | 1    | 1             | Coupling ring                        | 701 00 196*++ | D80x21          | Vulkollan  | See Fig. 5-11.  |
| 37                    | 1                        | 1   |     |      |      |               | Coupling, complete                   | 570 42 130*   | D58x60          |            | Includes pump-side and motor-side coupling and Pos. No. 36. |
| 37                    |                          |     | 1   | 1    |      |               | Coupling, complete                   | 570 42 134*   | D58x61          |            |   |
| 37                    |                          |     |     |      | 1    |               | Coupling, complete                   | 570 42 132*   | D85x85          | Cast iron  |   |
| 37                    |                          |     |     |      |      | 1             | Coupling, complete                   | 570 42 133*   | D85x85          | Cast iron  | See Fig. 5-3.   |

\*Included in module (see page 57 of parts list).

+Included in module repair kit (see page 57 of parts list).

++Included in universal gasket set and module repair kit (see page 57 of parts list).

Stl — steel

Vulkollan — vulcanized rubber

Buna-N — synthetic rubber

Viton — heat resistant synthetic rubber

D — diameter

| Position No. on Figs. | Number Required per Unit |     |     |      |      |           | Part Name                            | Catalog No.   | Dimensions (mm) | Material | Remarks   |
|-----------------------|--------------------------|-----|-----|------|------|-----------|--------------------------------------|---------------|-----------------|----------|---|
|                       | Pump Model               |     |     |      |      |           |                                      |               |                 |          |   |
|                       | D2A                      | D4A | D8A | D16A | D30A | D60A/D90A |                                      |               |                 |          |   |
| 38                    | 1                        | 1   |     |      |      |           | COUPLING ASSEMBLY (Cont'd.)          |               |                 |          |   |
| 38                    |                          |     | 1   | 1    |      |           | Key (coupling)                       | 221 16 065*   | 4x4x18          | Steel    |   |
| 38                    |                          |     |     |      | 1    | 1         | Key (coupling)                       | 221 16 151*   | 5x5x18          | Steel    |   |
|                       |                          |     |     |      |      |           | Key (coupling)                       | 221 16 179*   | 6x6x22          | Steel    |   |
| 39                    | 1                        | 1   |     |      |      |           | CENTRIFUGAL SWITCH AND RETAINER RING |               |                 |          |   |
| 39                    |                          |     | 1   | 1    |      |           | Centrifugal switch                   | 500 36 123*   | D60x23          | Brs, Stl |   |
| 39                    |                          |     |     |      | 1    | 1         | Centrifugal switch                   | 500 36 128*   | D70x27          | Brs, Stl |   |
| 39                    |                          |     |     |      |      |           | Centrifugal switch                   | 500 36 147*   | D60x23          | Brs, Stl |   |
| 40                    | 1                        | 1   |     |      |      |           | Retainer ring                        | 231 03 101*   | D12x1           | Steel    |   |
| 40                    |                          |     | 1   | 1    |      |           | Retainer ring                        | 231 03 104*   | D15x1           | Steel    |   |
| 40                    |                          |     |     |      | 3    | 3         | Retainer ring                        | 231 03 111*   | D22x1.2         | Steel    | The 2 additional rings fit onto the shaft on both sides of the second stage rotor.      |
| 41                    | 1                        | 1   |     |      |      |           | LEVER ASSEMBLY                       |               |                 |          |   |
| 41                    |                          |     | 1   | 1    |      |           | Lever                                | 281 53 130*   | 73x36           | Steel    |   |
| 41                    |                          |     |     |      | 1    | 1         | Lever                                | 281 53 102*   | 88x40x1         | Steel    |   |
| 41                    |                          |     |     |      |      |           | Lever                                | 281 53 101*   | 109x40x1        | Steel    |   |
| 42                    | 1                        | 1   |     |      |      |           | Spring (lever)                       | 221 61 199*   | D5.8x18x0.4     | Steel    |   |
| 42                    |                          |     | 1   | 1    | 1    | 1         | Spring (lever)                       | 221 62 141*   | D8.5x23         | Steel    |   |
| 43                    | 1                        | 1   | 1   | 1    | 1    | 1         | Seal (lever)                         | 239 73 131*++ | D9x11           | Buna-N   |   |
| 44                    | 1                        | 1   |     |      |      |           | SECOND STAGE ASSEMBLY                |               |                 |          |   |
| 44                    |                          |     | 1   | 1    |      |           | Front end plate                      | 301 51 138*   | D12x18          | Cl, Brz  |   |
| 44                    |                          |     |     |      | 1    | 1         | Front end plate                      | 301 51 137*   | D15x23          | Cl, Brz  |   |
| 44                    |                          |     |     |      |      |           | Front end plate                      | 301 51 140*   | D40x27          | Cl       |   |
| 45                    | 2                        | 2   |     |      |      |           | Radial shaft seal                    | 239 53 124*++ | D12x28x7        | Viton    |   |
| 45                    |                          |     | 2   | 2    |      |           | Radial shaft seal                    | 239 53 142*++ | D15x32x7        | Viton    |   |
| 45                    |                          |     |     |      | 2    | 2         | Radial shaft seal                    | 239 53 110*++ | D22x40x7        | Viton    | One of the seals fits into the front end plate; the other fits into the rear end plate. |

\* Included in module (see Page 57 of parts list).  
 ++ Included in universal gasket set and module repair kit (see page 57 of parts list).

Stl - steel  
 Cl - cast iron  
 Viton - heat resistant synthetic rubber

D - diameter  
 Brs - brass  
 Brz - bronze

| Position No. on Figs. | Number Required per Unit |     |     |      |      |           | Part Name   | Catalog No.   | Dimensions (mm) | Material      | Remarks   |
|-----------------------|--------------------------|-----|-----|------|------|-----------|---|---------------|-----------------|---------------|---|
|                       | Pump Model               |     |     |      |      |           |   |               |                 |               |   |
|                       | D2A                      | D4A | D8A | D16A | D30A | D60A/D90A |   |               |                 |               |   |
| 46                    | 1                        | 1   |     | 1    |      |           | SECOND STAGE ASSEMBLY (Cont'd.)<br>Second stage pump cylinder | 231 58 117*   | D54.8x35        | CI            |   |
| 46                    |                          |     | 1   | 1    |      |           | Second stage pump cylinder                                    | 231 58 124*   | D79x45          | CI            |   |
| 46                    |                          |     |     |      | 1    | 1         | Second stage pump cylinder                                    | 231 58 122*   | D118.5x75       | CI            |   |
| 47                    | 4                        | 4   |     |      |      |           | O-ring  | 239 70 409*++ | D60x2           | Viton         | Two of these O-rings go on the second stage pump cylinder; the other two go on the high vacuum stage pump cylinder. |
| 47                    |                          |     | 4   | 4    |      |           | O-ring  | 239 70 156*++ | D86x2           | Viton         |   |
| 47                    |                          |     |     |      | 4    | 4         | O-ring  | 239 70 411*++ | D122x3          | Viton         |   |
|                       |                          |     |     |      |      |           | Oil nozzle  |               |                 |               | See Position No. 56.  |
| 48                    | 1                        |     |     |      |      |           | Rotor with shaft  | 481 21 242*   | D48x151         | CI, Stl       |   |
| 48                    |                          | 1   |     |      |      |           | Rotor with shaft  | 481 21 243*   | D48x186         | CI, Stl       |   |
| 48                    |                          |     | 1   |      |      |           | Rotor with shaft  | 481 21 238*   | D68x183         | CI, Stl       |   |
| 48                    |                          |     |     | 1    |      |           | Rotor with shaft  | 481 21 239*   | D68x228         | CI, Stl       |   |
| 48                    |                          |     |     |      | 1    |           | Rotor   | 321 66 119*   | D101 x 75       | CI            |   |
| 48                    |                          |     |     |      | 1    |           | Shaft   | 401 57 294*   |                 | Stl           |   |
| 48                    |                          |     |     |      |      | 1         | Rotor   | 321 66 119*   | D101 x 75       | CI            |   |
| 48                    |                          |     |     |      |      | 1         | Shaft   | 401 57 296*   |                 | Stl           |   |
| 49                    | 3                        | 3   |     |      |      |           | Vane  | 411 55 112*+  | 14x35x4.5       | Ferobestos EC |   |
| 49                    |                          |     | 3   | 3    |      |           | Vane  | 411 55 155*+  | 22x45x4.5       | Ferobestos EC |   |
| 49                    |                          |     |     |      | 3    | 3         | Vane  | 411 55 116*+  | 32.5x75x4.5     | Ferobestos EC |   |

\*Included in module (see page 57 of parts list).

+Included in module repair kit (see page 57 of parts list).

++Included in universal gasket set and module repair kit (see page 57 of parts list).

Stl - steel

CI - cast iron

Viton - heat resistant synthetic rubber

D - diameter



| Position No. on Figs. | Number Required per Unit |     |     |      |      |           | Part Name                       | Catalog No.  | Dimensions (mm) | Material        | Remarks   |
|-----------------------|--------------------------|-----|-----|------|------|-----------|---------------------------------|--------------|-----------------|-----------------|---|
|                       | Pump Model               |     |     |      |      |           |                                 |              |                 |                 |   |
|                       | D2A                      | D4A | D8A | D16A | D30A | D60A/D90A |                                 |              |                 |                 |   |
| 50                    | 1                        | 1   |     |      |      |           | SECOND STAGE ASSEMBLY (Cont'd.) |              |                 |                 |   |
| 50                    |                          |     | 1   | 1    |      |           | Valve plate (standard)          | 401 64 109*+ | 45x35x0.1       | Stl             | For strd. series pumps.                                 |
| 50                    |                          |     |     |      | 1    | 1         | Valve plate (standard)          | 401 64 116*+ | 63x45x0.1       | Stainless steel |   |
| 50                    | 1                        | 1   |     |      |      |           | Valve plate (corrosive)         | 401 64 114*+ | 75x82x0.2       | Stl             | For strd. series pumps.                                 |
| 50                    |                          |     | 1   | 1    |      |           | Valve plate (corrosive)         | 401 64 121*+ | 45x35x0.1       | Gold plated     | For corr. series pumps.                                 |
| 50                    |                          |     |     |      | 1    | 1         | Valve plate (corrosive)         | 401 64 116*+ | 63x45x0.1       | Stainless steel | For corr. series pumps.                                 |
| 50                    |                          |     |     |      |      | 1         | Valve plate (corrosive)         | 401 64 124*+ | 75x82x0.2       | Gold plated     | For corr. series pumps.                                 |
| 51                    | 1                        | 1   |     |      |      |           | Valve stop                      | 373 58 103*  | 34.6x45x10      | Black plastic   | The valve stop in the Figures is made of black plastic. |
| 51                    |                          |     | 1   | 1    |      |           | Valve stop                      | 373 58 107*  | 63x45x9         | Black plastic   |   |
| 51                    |                          |     |     |      | 1    | 1         | Valve stop                      | 373 58 106*  | 80x74.5x12      | Al-aly          |   |
| 52                    | 1                        | 1   |     |      |      |           | Center bearing                  | 261 51 132*  | D12x15          | Cast iron       |   |
| 52                    |                          |     | 1   | 1    |      |           | Center bearing                  | 261 51 131*  | D15x15          | Cast iron       |   |
| 52                    |                          |     |     |      | 1    | 1         | Intermediate plate              | 261 51 135*  | D30x30          | Cast iron       |   |
| 53                    | 3                        |     |     |      |      |           | HIGH VACUUM STAGE ASSEMBLY      |              |                 |                 |   |
| 53                    |                          | 3   |     |      |      |           | Vane                            | 411 55 112*+ | 14x35x4.5       | Ferobestos EC   |   |
| 53                    |                          |     | 3   |      |      |           | Vane                            | 411 55 113*+ | 14x70x4.5       | Ferobestos EC   |   |
| 53                    |                          |     |     | 3    |      |           | Vane                            | 411 55 155*+ | 22x45x4.5       | Ferobestos EC   |   |
| 53                    |                          |     |     |      | 3    |           | Vane                            | 411 55 154*+ | 22x90x4.5       | Ferobestos EC   |   |
| 53                    |                          |     |     |      |      | 3         | Vane                            | 411 55 116*+ | 32.5x75x4.5     | Ferobestos EC   |   |
| 53                    |                          |     |     |      |      | 3         | Vane                            | 411 55 115*+ | 32.5x150x4.5    | Ferobestos EC   |   |

\* Included in module (see page 57 of parts list).  
 + Included in module repair kit (see page 57 of parts list).

D – diameter  
 Duroplast – durable thermoplastic  
 Al-aly – aluminum alloy

| Position No. on Figs. | Number Required per Unit |     |     |      |      |           | Part Name                            | Catalog No.   | Dimensions (mm) | Material   | Remarks  |
|-----------------------|--------------------------|-----|-----|------|------|-----------|--------------------------------------|---------------|-----------------|------------|--|
|                       | Pump Model               |     |     |      |      |           |                                      |               |                 |            |  |
|                       | D2A                      | D4A | D8A | D16A | D30A | D60A/D90A |                                      |               |                 |            |  |
| 54                    | 1                        |     |     |      |      |           | HIGH VACUUM STAGE ASSEMBLY (Cont'd.) |               |                 |            |  |
| 54                    |                          | 1   |     |      |      |           | Rotor, HV stage                      | 321 66 126*   | D48x35          | Cast iron  |  |
| 54                    |                          |     | 1   |      |      |           | Rotor, HV stage                      | 321 66 125*   | D48x70          | Cast iron  |  |
| 54                    |                          |     |     | 1    |      |           | Rotor, HV stage                      | 321 66 123*   | D68x45          | Cast iron  |  |
| 54                    |                          |     |     |      | 1    |           | Rotor, HV stage                      | 321 66 122*   | D68x90          | Cast iron  |  |
| 54                    |                          |     |     |      |      | 1         | Rotor, ‡                             | 321 66 119*   | D101x75         | Cast iron  | ‡  |
| 54                    |                          |     |     |      |      | 1         | Rotor, HV stage                      | 321 66 120*   | D101x150        | Cast iron  |  |
| 55                    | 1                        |     |     |      |      |           | Pump cylinder, HV stage              | 231 65 117*   | D54.8x35        | Cast iron  |  |
| 55                    |                          | 1   |     |      |      |           | Pump cylinder, HV stage              | 231 65 116*   | D54.8x70        | Cast iron  |  |
| 55                    |                          |     | 1   |      |      |           | Pump cylinder, HV stage              | 231 65 121*   | D79x45          | Cast iron  |  |
| 55                    |                          |     |     | 1    |      |           | Pump cylinder, HV stage              | 231 65 122*   | D79x90          | Cast iron  |  |
| 55                    |                          |     |     |      | 1    |           | Pump cylinder, HV stage              | 231 65 118*   | D118.5x75       | Cast iron  |  |
| 55                    |                          |     |     |      |      | 1         | Pump cylinder, HV stage              | 231 65 107*   | D118.5x150      | Cast iron  |  |
|                       |                          |     |     |      |      |           | O-rings                              |               |                 |            | See position 47.   |
| 56                    | 1                        | 1   |     |      |      |           | Oil nozzle                           | 392 25 107*   | 0.5             | Brass      | The oil nozzle is located in the second stage pump cylinder. |
| 56                    |                          |     | 1   | 1    |      |           | Oil nozzle                           | 392 25 113*   | 0.8             | Brass      |  |
| 56                    |                          |     |     |      | 2    | 2         | Oil nozzle                           | 392 25 124*   | 1.5             | Brass      |  |
|                       |                          |     |     |      |      |           | Radial shaft seal                    |               |                 |            | See position 45.   |
| 57                    | 1                        | 1   |     |      |      |           | Key (rotor)                          | 221 16 070*   | 4x4x28          | Stl        | See Fig. 5-9.  |
| 57                    |                          |     | 1   | 1    |      |           | Key (rotor)                          | 221 16 156*   | 5x5x28          | Stl        | See Fig. 5-9.  |
| 57                    |                          |     |     |      | 2    | 2         | Key (rotor)                          | 221 16 188*   | 6x6x50          | Stl        | See Fig. 5-9.  |
| 58                    |                          | 1   |     | 1    |      |           | Valve plate                          | 400 50 135*++ | 16x16x5         | Stl, Viton | See Fig. 5-13.   |
| 58                    |                          |     |     |      |      | 2         | Valve plate                          | 400 50 138*++ | 25x25x5         | Stl, Viton | See Fig. 5-13.   |

\*Included in module (see page 57 of parts list).

++Included in universal gasket set and module repair kit (see page 57 of parts list).

‡ Both rotors are the same part number on the D30A pump model.

D – diameter

Stl – steel

Viton – heat resistant synthetic rubber

HV – high vacuum

| Position No. on Figs. | Number Required per Unit |     |     |      |      |           | Part Name                                   | Catalog No. | Dimensions (mm) | Material  | Remarks  |
|-----------------------|--------------------------|-----|-----|------|------|-----------|---|-------------|-----------------|-----------|--|
|                       | Pump Model               |     |     |      |      |           |   |             |                 |           |  |
|                       | D2A                      | D4A | D8A | D16A | D30A | D60A/D90A |   |             |                 |           |  |
|                       |                          |     |     |      |      |           | <b>HIGH VACUUM STAGE ASSEMBLY (Cont'd.)</b> |             |                 |           |  |
| 59                    |                          | 1   |     |      |      |           | Retaining bracket                           | 491 60 109* | 40x8x4          | Steel     | See Fig. 5-13.<br>See Fig. 5-13.<br>See Fig. 5-13. |
| 59                    |                          |     |     | 1    |      |           | Retaining bracket                           | 491 60 107* | 40x10x8         | Steel     |  |
| 59                    |                          |     |     |      |      | 2         | Retaining bracket                           | 491 60 111* | 52x4x4          | Steel     |  |
| 60                    | 1                        | 1   |     |      |      |           | Rear end plate                              | 351 55 131* | D12x16          | Cast iron |  |
| 60                    |                          |     | 1   | 1    |      |           | Rear end plate                              | 351 55 130* | D15x18          | Cast iron |  |
| 60                    |                          |     |     |      | 1    | 1         | Rear end plate                              | 351 55 132* | D40x28          | Cast iron |  |
| 61                    | 1                        | 1   | 1   | 1    | 1    | 1         | Disk (oil slinger)                          | 451 74 335* | D85x2.1         | Steel     |  |
|                       |                          |     |     |      |      |           | <b>MODULE STUDS AND PINS</b>                |             |                 |           |  |
| 62                    | 3                        |     |     |      |      |           | Threaded stud                               | 201 52 104* | D6x107          | Steel     |  |
| 62                    |                          | 3   |     |      |      |           | Threaded stud                               | 201 52 103* | D6x142          | Steel     |  |
| 62                    |                          |     | 4   |      |      |           | Threaded stud                               | 201 52 109* | D6x133          | Steel     |  |
| 62                    |                          |     |     | 4    |      |           | Threaded stud                               | 201 52 110* | D6x178          | Steel     |  |
| 62                    |                          |     |     |      | 3    |           | Threaded stud                               | 201 52 106* | D8x218          | Steel     |  |
| 62                    |                          |     |     |      |      | 3         | Threaded stud                               | 201 52 108* | D8x293          | Steel     |  |
| 63                    | 3                        | 3   | 4   | 4    |      |           | Hexagon nut                                 | 211 01 312* | D6              | Steel     |  |
| 63                    |                          |     |     |      | 3    | 3         | Hexagon nut                                 | 211 01 314* | D8x8            |           |  |
| 64                    | 4                        | 4   | 4   | 4    |      |           | Cylindrical pin                             | 241 03 585* | D8x20           | Steel     | For rear end plate                                 |
| 64                    |                          |     |     |      | 2    | 2         | Cylindrical pin                             | 241 03 586* | D8x24           |           |  |
| 64                    |                          |     |     |      | 2    | 2         | Cylindrical pin                             | 241 03 590* | D8x40           | Steel     | For front end plate                                |
| 65                    | 2                        | 2   | 2   | 2    |      |           | Cylindrical pin                             | 241 03 590* | D8x40           | Steel     |  |
| 65                    |                          |     |     |      | 2    | 2         | Cylindrical pin                             | 241 03 593* | D8x60           |           |  |

\*Included in module (see page 57 of parts list).

D - Diameter

| Position No. on Figs. | Number Required per Unit |     |     |      |      |           | Part Name                  | Catalog No.   | Dimensions (mm) | Material   | Remarks  |
|-----------------------|--------------------------|-----|-----|------|------|-----------|----------------------------|---------------|-----------------|------------|--|
|                       | Pump Model               |     |     |      |      |           |                            |               |                 |            |  |
|                       | D2A                      | D4A | D8A | D16A | D30A | D60A/D90A |                            |               |                 |            |  |
|                       |                          |     |     |      |      |           | ANTI-SUCK BACK ASSEMBLY    |               |                 |            |  |
|                       |                          |     |     |      |      |           | Centrifugal switch         |               |                 |            | See position 39.   |
|                       |                          |     |     |      |      |           | Lever                      |               |                 |            | See position 41.   |
|                       |                          |     |     |      |      |           | Spring (lever)             |               |                 |            | See position 42.   |
|                       |                          |     |     |      |      |           | Seal (lever)               |               |                 |            | See position 43.   |
| 66                    |                          |     |     |      | 1    | 1         | Air nozzle                 | 392 25 204    | 0.36            | Brass      | Not shown in Figures   |
| 67                    | 1                        | 1   |     |      |      |           | Valve disk                 | 400 50 136*++ | D20             | Stl, Viton |  |
| 67                    |                          |     | 1   | 1    |      |           | Valve disk                 | 400 50 139*++ | D32             | Stl, Viton |  |
| 67                    |                          |     |     |      | 1    | 1         | Valve disk                 | 400 50 137*++ | D45             | Stl, Viton |  |
| 68                    | 1                        | 1   |     |      |      |           | Piston                     | 321 06 130*   | D7.9x26         | Brass      |  |
| 68                    |                          |     | 1   | 1    |      |           | Piston                     | 321 06 104*   | D12x30          | Brass      |  |
| 68                    |                          |     |     |      | 1    | 1         | Piston                     | 321 06 131*   | D12x22          | Brass      |  |
| 69                    | 1                        | 1   |     |      |      |           | Air inlet tube             | 431 31 161*   | D8x79           | Steel      |  |
| 69                    |                          |     | 1   | 1    |      |           | Air inlet tube             | 431 31 177*   | D8x92.5         | Steel      |  |
| 69                    |                          |     |     |      | 1    | 1         | Air inlet tube             | 431 31 174*   | D8x144          | Steel      |  |
| 70                    | 2                        | 2   | 2   | 2    | 2    | 2         | O-ring                     | 239 70 148*++ | D5x2            | Viton      |  |
| 71                    | 1                        | 1   |     |      |      |           | Retainer disk              | 231 05 107*   | D5              | Steel      |  |
| 71                    |                          |     | 1   | 1    | 1    | 1         | Retainer disk              | 231 05 108*   | D6              | Steel      |  |
| 72                    | 1                        | 1   |     |      |      |           | OIL SIGHT GAUGE ASSEMBLIES | 720 00 113    | 5 11/32"x5/8"   | Aluminum   |  |
| 72                    |                          |     | 1   | 1    |      |           |                            | 720 00 114    | 5 11/32"x5/8"   | Aluminum   |  |
| 72                    |                          |     |     |      | 1    | 1         |                            | 720 00 115    | 6 13/16"x5/8"   | Aluminum   |  |
| 72A                   | 2                        | 2   | 2   | 2    | 2    | 2         | Mounting bolt              | 720 00 129    | 5/16-24 UNF-2A  |            | A mounting bolt with 2 flat gaskets (72B) is available under Part No. 720 00 118 |
| 72B                   | 2                        | 2   | 2   | 2    | 2    | 2         | Flat gasket                | 725 90 001++  |                 | Viton      | A seal kit containing these 4 seals is available under Part No. 720 00 116       |
| 72C                   | 2                        | 2   | 2   | 2    | 2    | 2         | O-ring                     | 725 91 001++  |                 | Viton      |  |
| 72D                   | 2                        | 2   | 2   | 2    | 2    | 2         | Flat gasket                | 725 90 000++  |                 | Viton      |  |
| 72E                   | 2                        | 2   | 2   | 2    | 2    | 2         | O-ring                     | 725 91 000++  |                 | Viton      |  |
| 72F                   | 1                        | 1   | 1   | 1    |      |           | Sight tube                 | 722 11 003    |                 | Glass      |  |
|                       |                          |     |     |      | 1    | 1         | Sight tube                 | 722 11 004    |                 | Glass      |  |

\*Included in module (see page 57 of parts list)

++Included in module repair kit and universal gasket set (see page 57 of parts list)

D - Diameter  
 C al-aly - cast aluminum alloy  
 M - motor side adapter flange  
 P - pump side adapter flange  
 Viton - heat resistant synthetic rubber  
 Al - aluminum

| Position<br>No. on<br>Figs. | Number Required per Unit |     |     |      |      |      | Part Name | Motor<br>Specifications  | Motor<br>Part No. |
|-----------------------------|--------------------------|-----|-----|------|------|------|-----------|--|-------------------|
|                             | Pump Model               |     |     |      |      |      |           |  |                   |
|                             | D2A                      | D4A | D8A | D16A | D30A | D60A |           |  |                   |
| 73                          | 1                        | 1   |     |      |      |      | Motor *   | 1/3 hp, TEFC, 1 ph<br>115/208-230V, 60 Hz, 1725 rpm<br>115/208-230V, 50 Hz, 1500 rpm<br>Wired for 115V | 722-60-066*       |
| 73                          | 1                        | 1   |     |      |      |      | Motor     | 1/3hp, TEFC, 3ph<br>200/230/460V, 60 Hz, 1725 rpm<br>200/220/380V, 50Hz, 1500 rpm                      | 722-60-067        |
| 73                          |                          |     |     | 1    |      |      | Motor*    | 1 hp, TEFC, 1 ph<br>115/208-230V wired for 115V<br>50/60 Hz, 1500/1725 rpm                             | 722-60-069*       |

\* This motor has an automatic resetting thermal overload.

hp—horsepower  
kw—kilowatt  
V—voltage  
VAC—voltage, alternating current  
ph—phase  
Hz—hertz  
TEFC—totally enclosed fan cooled  
rpm—revolutions per minute

| Position<br>No. on<br>Figs. | Number Required per Unit |     |     |      |      |      | Part Name | Motor<br>Specifications   | Motor<br>Part No. |
|-----------------------------|--------------------------|-----|-----|------|------|------|-----------|---|-------------------|
|                             | Pump Model               |     |     |      |      |      |           |   |                   |
|                             | D2A                      | D4A | D8A | D16A | D30A | D60A |           |   |                   |
| 73                          |                          |     | 1   | 1    |      |      | Motor     | 1 hp, 1 ph, TEFC<br>208-230V, wired for 208V<br>50/60 Hz, 1500/1725 rpm               | 722-60-005†       |
| 73                          |                          |     | 1   | 1    |      |      | Motor     | 1 hp, TEFC, 3 ph<br>208/230/460V, 60 Hz, 1725 rpm<br>200/220/380V, 50 Hz, 1500 rpm    | 722-60-070        |
| 73                          |                          |     |     |      | 1    |      | Motor     | 1-1/2 hp, TEFC, 3 ph<br>208-230/460V, 60Hz, 1725 rpm<br>200-220/380V, 50 Hz, 1500 rpm | 722-60-076*       |
| 73                          |                          |     |     |      | 1    |      | Motor     | 2 hp, 1 ph, TEFC, 208-230V,<br>wired for 208V, 60 Hz, 1725 rpm                        | 722-60-007†       |

\* This motor has a rotational lock bearing.

† This motor has an automatic resetting thermal overload.

hp – horsepower  
kw – kilowatt  
V – voltage  
VAC – voltage, alternating current  
ph – phase  
Hz – hertz  
TEFC – totally enclosed fan cooled  
rpm – revolutions per minute

| Position<br>No. on<br>Figs. | Number Required per Unit |     |     |      |      |      |      | Part Name | Motor<br>Specifications   | Motor<br>Part No.†† |
|-----------------------------|--------------------------|-----|-----|------|------|------|------|-----------|---|---------------------|
|                             | Pump Model               |     |     |      |      |      |      |           |   |                     |
|                             | D2A                      | D4A | D8A | D16A | D30A | D60A | D90A |           |   |                     |
| 73                          |                          |     |     |      |      | 1    |      | Motor     | 2 hp, 3 ph, TEFC<br>200-230/460V, 1200 rpm, 60Hz<br>200-220/380V, 1000 rpm, 50Hz  | 722-60-074          |
| 73                          |                          |     |     |      |      | 1    | 1    | Motor     | 3 hp, TEFC, 3 ph<br>208/230/460V, 60Hz, 1800 rpm<br>200-220/380V, 50 Hz, 1500 rpm | 722-60-013          |

†† A rotational lock bearing has been installed on all motors listed on this page.

hp – horsepower  
kw – kilowatt  
V – voltage  
VAC – voltage, alternating current  
ph – phase  
Hz – hertz  
TEFC – totally enclosed fan cooled  
rpm – revolutions per minute



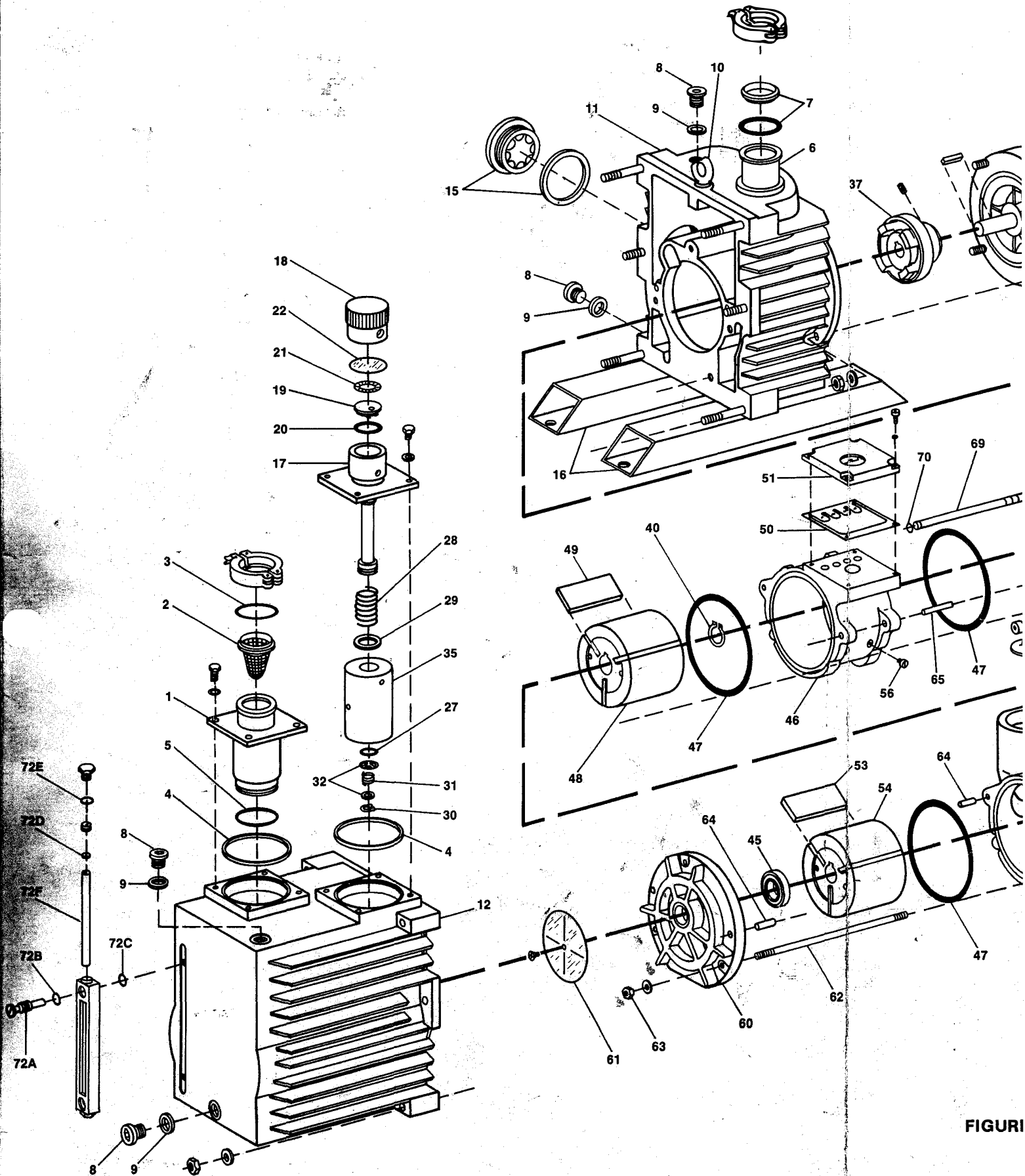

FIGURI

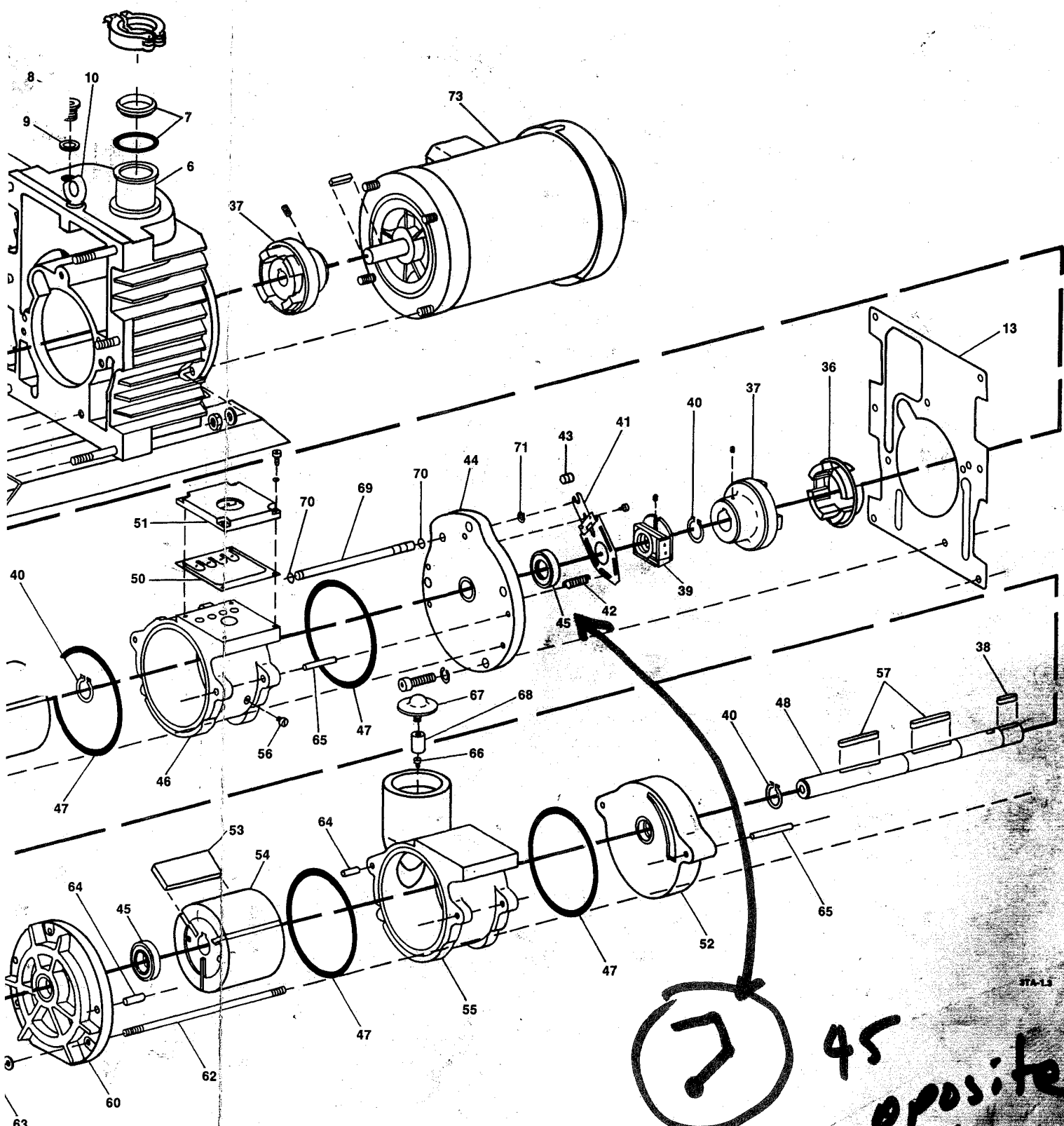

FIGURE 7-2. EXPLODED ISOMETRIC DRAWING OF A D30A PUMP MODEL

Put in last.

45  
opposite  
of what  
you would  
expect.