



TRIVAC[®] T D4/8/16/30T

Two-Stage Rotary Vane Pump

Original Operating Instructions 300598802_002_C0

Part No:

312 31TE
312 36TE
312 41TE
312 46TE
312 51TE
312 56TE
312 61TE
312 66TE
and other variants



FOR SALES AND SERVICE PLEASE CALL:

PTB SALES ☎ :: 626.334.0500
sales@ptbsales.com
service@ptbsales.com
www.ptbsales.com

DATE SERVICED: _____

VIEW OUR INVENTORY



Contents

	Page
0	Important Safety Information 4
0.1	Mechanical hazards 4
0.2	Electrical hazards 4
0.3	Thermal hazards 5
0.4	Hazards caused by materials and substances 5
0.5	Danger of ignition 5
0.6	Hazard caused by noise 5
0.7	Risk of damaging the pump 6
1	Description 7
1.1	Function 7
1.2	Lubricants 9
1.3	Supplied Equipment 9
1.4	Accessories 10
1.5	Technical Data 11
2	Transport and Storing 14
3	Installation 15
3.1	Placement 15
3.2	Conforming Utilization 16
3.2.1	Non-conforming Utilization 16
3.3	Connection to the System 17
3.4	Electrical Connections 18
4	Operation 20
4.1	Media Compatibility 20
4.2	Start-up 20
4.2.1	Start noise 20
4.3	Operation 21
4.3.1	Pumping of Non-Condensable Gases and Vapours 21
4.3.2	Pumping of Condensable Gases and Vapours 21
4.3.3	Operating Temperature 22
4.4	Shutdown 22
4.4.1	Controller/Mains Power Failure 22
5	Maintenance 23
5.1	Maintenance Plan 24
5.2	Leybold Service 25
5.3	Monitoring the Oil Level 26
5.3.1	Checking the Condition of LVO 108 26
5.4	Oil Change 27
5.5	Cleaning the Inlet Screen 28
5.6	Disassembly and Reassembly of the Electric Motor 29
5.6.1	Checking the Coupling 29
5.7	Maintaining the Gas Ballast Valve 30
6	Troubleshooting 32
7	Wearing Parts and Original Spare Parts 34
8	Waste Disposal 35
	EC Declaration of Conformity 36

Obligation to Provide Information

Before installing and commissioning the TRIVAC® T, carefully read these Operating Instructions and follow the information so as to ensure optimum and safe working right from the start.

The Leybold TRIVAC® T has been designed for safe and efficient operation when used properly and in accordance with these Operating Instructions. It is the responsibility of the user to carefully read and strictly observe all safety precautions described in this section and throughout the Operating Instructions. The pump **must only be operated in the proper condition and under the conditions described in the Operating Instructions**. It must be operated and maintained by trained personnel only. Consult local, state, and national agencies regarding specific requirements and regulations. Address any further safety, operation and/or maintenance questions to our nearest office.

DANGER indicates an imminently hazardous situation which, if not avoided, will result in death or serious injury.

WARNING indicates a potentially hazardous situation which, if not avoided, could result in death or serious injury.

CAUTION indicates a potentially hazardous situation which, if not avoided, could result in minor or moderate injury.

NOTICE is used to notify users of installation, operation, programming or maintenance information that is important, but not hazard related.

TRIVAC® T pumps are not designed:

- for pumping of dusty, aggressive, corrosive, flammable or explosive gases or gases mixtures;
- for pumping of oxygen or other highly reactive gases with a greater concentration than atmospheric concentration (>21%);
- for working in flammable, explosive or dusty environment.

For all these cases, special materials must be used. In case of doubt, please contact Leybold.

Figures

The references to figures, e.g. (4/2) consist of the consecutive Fig. No. and the Item No. in that order.

We reserve the right to alter the design or any data given in these Operating Instructions. The illustrations are not binding.

Retain the Operating Instructions for further use.

NOTICE



DANGER



WARNING



CAUTION



NOTICE



WARNING



Safety information

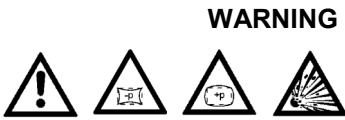

0 Important Safety Information

0.1 Mechanical hazards

- 1 Avoid exposing any part of the human body to the vacuum.
- 2 Never operate the pump without a connected intake line or without fitting a blank flange on intake port.
- 3 Do not operate the pump with any of the covers removed. Serious injury may result.
- 4 The location at which the TRIVAC[®] T (including its accessories) is being operated should be such that angles over 10° from the vertical are avoided. Select the operating place so that all controls are easily accessible.
- 5 The pump when filled with oil must only be moved in its vertical position. Spilled oil involves the risk of falling.
- 6 Make sure that the gas flow from the exhaust port is not blocked or restricted in any way.
- 7 If exhaust gases must be collected or contained, do not allow the exhaust line to become pressurised. The pressure in the oil box must not exceed 1.5 bar (absolute). An exhaust line which is too small in diameter or which is blocked can result in the formation of overpressures within the pump. Possible consequences can be damage or even burst open the pump. Thus the exhaust line must be checked from time to time to ensure that there are no obstructions.
- 8 When moving the TRIVAC[®] T always use the lifting means provided.

WARNING



0.2 Electrical hazards

- 1 The electrical connections must only be provided by a trained electrician as specified, for example, by the regulations EN 50110-1. Observe local regulations.
- 2 Lethal voltages are present at the mains connections. Before starting with any maintenance and service work, de-energise (lockout/tagout) the product first.
- 3 Lay connecting lines so that they cannot be damaged. Protect the lines against humidity and contact with water. Avoid any heat stress on the line due to unfavourable laying conditions.
- 4 Suitably support the connecting lines so that the pumps are not exposed to any major mechanical stress.
- 5 After a mains power failure the pump will run up automatically again. This also applies in the case of an emergency shutdown. In order to prevent the pump from running up automatically again, the pump must be integrated within a control arrangement such that it can only be switched on manually again after the mains power has returned.
- 6 Provide an adequate wall ground connection for the pump so as to avoid any electrostatic charging.
- 7 Before starting up for the first time, the motor circuit must be equipped with a suitable protective motor switch. Please take note of the information in these Operating Instructions and on the electric motor (wiring diagram).

Safety information

0.3 Thermal hazards

- 1 Under certain ambient conditions the TRIVAC® T may attain a temperature of over 70 °C (158 °F). There then exists the danger of receiving burns.

Note the symbols on the pump pointing to the hazards, and in the case of a hot pump wear the required protective clothing. All work on the “pump still warm from operation” should only be done using protection gloves.

- 2 Before servicing and maintenance work always leave the pump to cool down.
- 3 Consider always the warning information on the housing surfaces. If these warning information have been removed, covered or obstructed, it's to secure that corresponding warning information will be attached again.

0.4 Hazards caused by materials and substances

- 1 The pump is not suited for oxygen operation (>21% oxygen).
- 2 Before commissioning the TRIVAC® T, make sure that the media which are to be pumped are compatible with each other so as to avoid hazardous situations. All relevant safety standards and regulations must be observed.
- 3 TRIVAC® T pumps cannot be used with toxic, chemical, radioactive and corrosive gases as well as pyrophorous substances.
- 4 If the pump has previously handled hazardous gases, implement the proper precautionary measures before opening the intake or exhaust connection.
Before opening the pump, purge it for a longer period of time with an inert gas.
If necessary, use gloves, a respirator and/or protective clothing and work under an exhaust hood. Firmly seal off the pump.
When shipping the contaminated pump for servicing, please also state the type of hazard. For this you must use a form which we have prepared for you.
- 5 When cleaning a system in which a TRIVAC® T pump has been integrated, all parts in contact with the medium need to be compatible with the cleaning agent so as to prevent a chemical reaction. Residues of the cleaning agent within the pump must be avoided.
- 6 Contaminated parts can be detrimental to health and environment. Before beginning with any work, first find out whether any parts are contaminated. Adhere to the relevant regulations and take the necessary precautions when handling contaminated parts.

0.5 Danger of ignition

- 1 The standard version of the TRIVAC® T is **not** suited for operation in explosion hazard areas.
- 2 The TRIVAC® T pumps including the accessories are fundamentally **not** suited for pumping of combustible and explosive gases or vapours.

0.6 Hazard caused by noise

- 1 The noise level produced by the pump is less than 60 dB(A).

CAUTION



DANGER



CAUTION



CAUTION



Safety information

NOTICE



0.7 Risk of damaging the pump

- 1 Do not allow the ingestion of small objects (screws, nuts, washers, pieces of wire, etc.) through the inlet port. For this reason always use the inlet screen which is supplied as standard.
- 2 Do not use the pump for applications that produce abrasive or adhesive powders or condensable vapours that can leave adhesive or high viscosity deposits. When planning to pump vapours other than water vapour please contact our sales or service department for advice.
- 3 This pump is suited for pumping water vapour within the specified water vapour tolerance limits.
- 4 Avoid vapours that can condense into liquids when being compressed inside the pump, if these substances exceed the vapour tolerance of the pump.
- 5 Before pumping vapours the TRIVAC[®] T should have attained its operating temperature. This will be the case approximately 30 minutes after having started the pump. During this warming up phase, the pump should be separated from the process, by a blocking valve in the intake line, for example.
- 6 In the case of wet processes we recommend the installation of liquid separators upstream and downstream of the pump as well as the use of the gas ballast.
- 7 The exhaust line should be laid so that it slopes down and away from the pump so as to prevent condensate from backstreaming into the pump.
- 8 The entry of particles and fluids must be avoided under all circumstances.
- 9 Reactive or aggressive substances in the pump chamber may impair the operating oil or modify it. In addition, such substances may be incompatible with the materials of the pump (Viton, grey cast iron, aluminium, steel, resins, glass etc.).
- 10 Corrosion, deposits and cracking of oil within the pump are not allowed.
- 11 Normal amounts of humidity within the range of the pump's water vapour tolerance will not significantly affect pump performance when the gas ballast is active.
- 12 When operating the pumps at gas throughput, it is urgently recommended to connect an exhaust filter or use a suitable exhaust line. Here, the exhaust line must slope down and away from the pump.
- 13 In the case of custom pumps please note the information provided in the supplementary sheets.

Description

1 Description

TRIVAC® T pumps are oil-sealed dual-stage rotary vane pumps. The number in the type designation (4, 8, 16 or 30) indicates the pumping speed in $\text{m}^3 \cdot \text{h}^{-1}$.

TRIVAC® T pumps are capable of pumping gases and vapours and evacuating vessels or vacuum systems down into with the medium vacuum range. The standard versions of the pump are not suited for pumping of oxygen exceeding the concentration as found in the atmosphere, and are also not suited for pumping of hazardous gases or extremely aggressive or corrosive media.

Areas of application

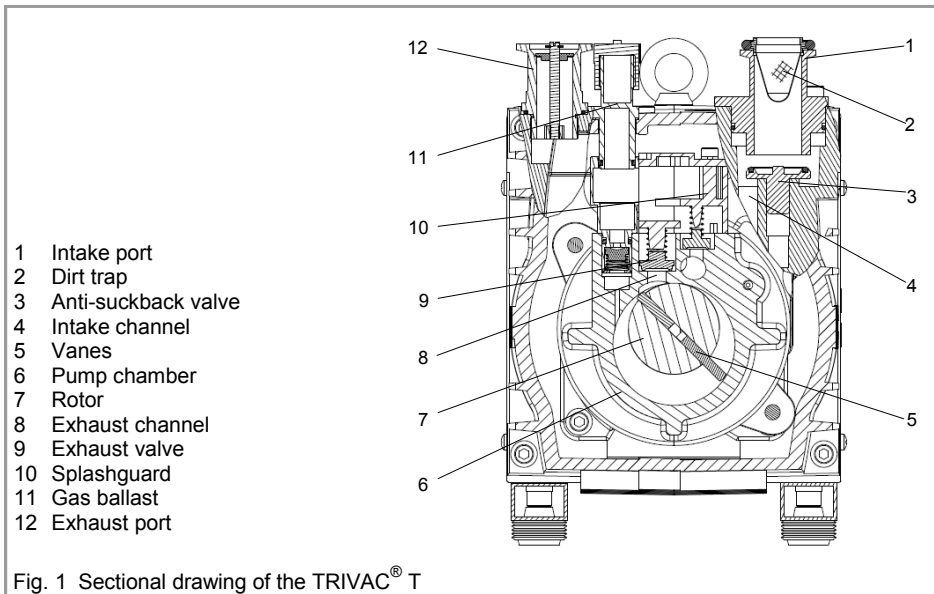

1.1 Function

The rotor (1/7), mounted eccentrically in the pump housing (1/6), has two radially sliding vanes (1/5) which divide the pump chamber into several compartments. The volume of each compartment changes periodically with the rotation of the rotor.

As a result, gas is sucked in at the intake port (1/1). The gas passes through the dirt trap sieve (1/2), flows past the open anti-suckback valve (1/3) and then enters the pump chamber. In the pump chamber, the gas is passed on and compressed, after the inlet aperture is closed by the vane.

The oil injected into the pump chamber is used for sealing and lubricating. The slap noise of the oil in the pump which usually occurs when attaining the ultimate pressure is prevented by admitting a very small amount of air into the pump chamber. Pump is already with silencing device.

The compressed gas in the pump chamber is ejected through the exhaust valve (1/9). The oil entrained in the gas is coarsely trapped in the internal splashguard (1/10); there the oil is also freed of mechanical impurities. The gas leaves the TRIVAC® T through the exhaust port.

During compression, a controlled amount of air - the so-called gas ballast - can be allowed to enter the pump chamber by opening the gas ballast valve. The gas ballast stops condensation of vapours in the pump chamber up to the limit of the water vapour tolerance as specified in the technical data for the pump.

Description

The gas ballast valve is opened and closed by turning the gas ballast knob (6/4) on the front.

To enable the TRIVAC[®] T to be used at intake pressures as high as 1,000 mbar, a special lubricating system was developed featuring force-lubrication of the sliding bearings.

An oil pump (2/5) pumps the oil from the oil reservoir (2/4) into a pressure lubrication system which supplies oil to all bearing points (2/1). From there the oil enters the pump chamber area (2/3) of the vacuum pump.

The oil pump is fitted in the high vacuum cylinder on the coupling side of the pump module. The oil suction line is placed low, resulting in a large usable oil reservoir.

The oil is separated from the gas in the TRIVAC[®] T in two steps as described above. First, small droplets are coalesced into large drops in the internal demister (1/10) fitted above the exhaust valve (1/9). Then, the large drops fall into the oil reservoir as the exhaust gas is diverted by the inner walls of the oil case. Thus a low loss of oil is obtained. This and the large usable oil reservoir ensure long intervals between oil changes even at high intake pressures.

The vacuum is maintained by the TRIVAC[®] T through an integrated anti-suckback valve (1/3) which is controlled via the oil pressure. During operation of the TRIVAC[®] T the control piston (3/2) remains sealed against a spring (3/1) by the oil pressure. The valve disk (3/5) of the antisuckback valve is held at the lower position by its own weight (valve open). When the pump stops (because it has been switched off or because of a failure), the oil pressure drops and the spring (3/1) presses the control piston (3/2) right. Thus a connection is provided between the oil case and the piston (3/3) of the anti-suckback valve.

Due to the pressure difference between the oil case and the intake port, the air presses the piston (3/3) up and the valve disc (3/5) against the valve seat (3/4), which vents the pump chamber and forces the valve disc against its seat. This effectively prevents backstreaming of oil or oil vapours. The anti-suckback valve (1/3) operates independently of the operating mode of the pump, i.e. also with gas ballast.

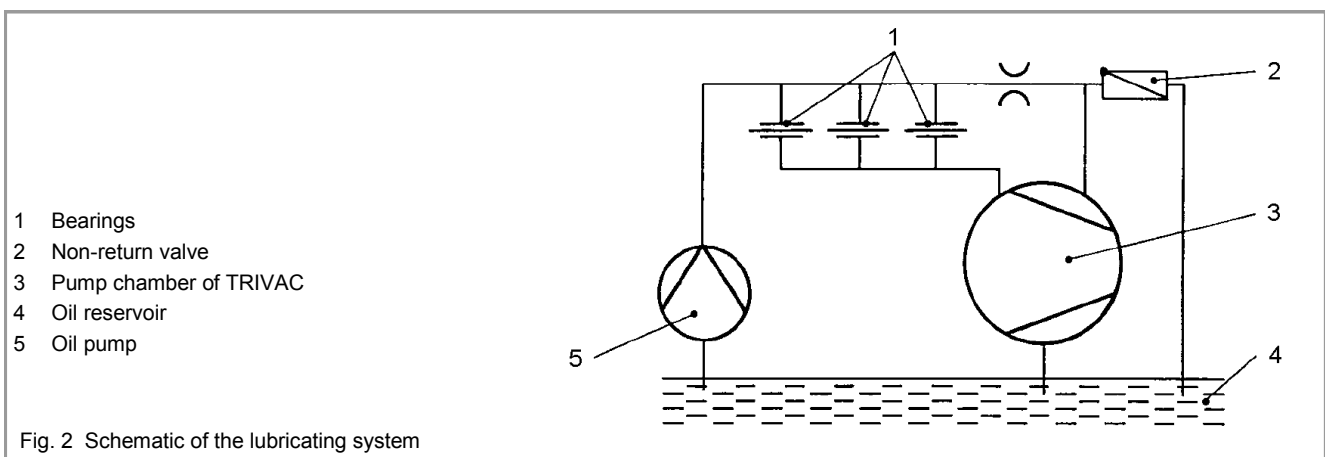

Description

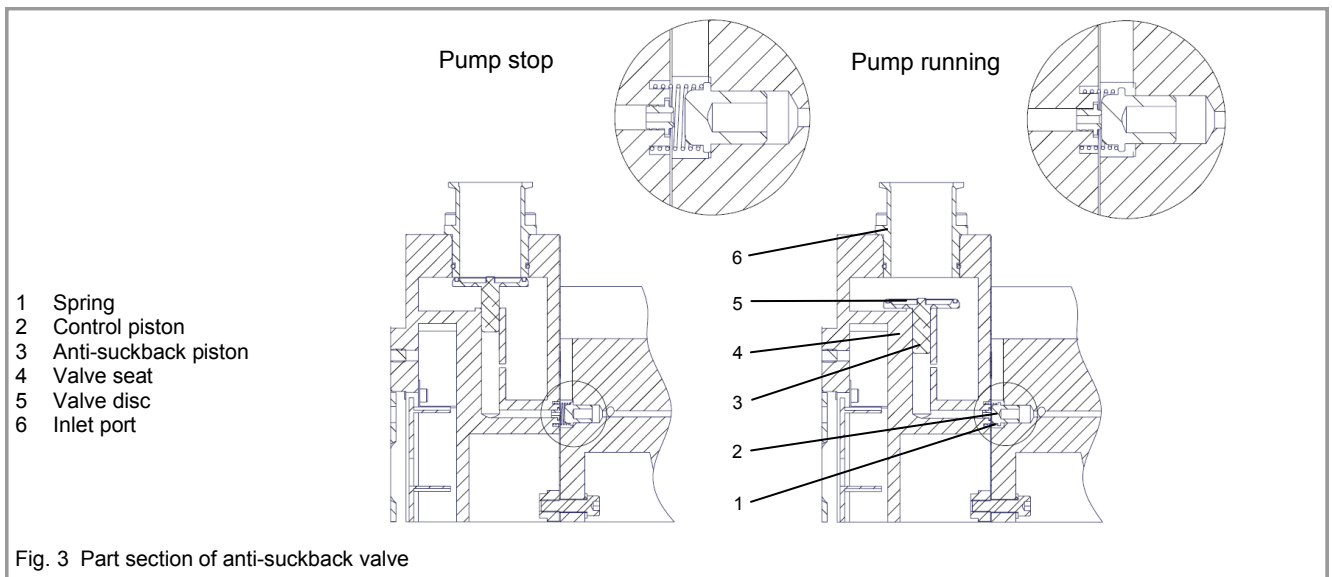

1.2 Lubricants

The standard TRIVAC[®] T pumps are ready for operation with mineral oil.
In case of operation of a TRIVAC[®] T we instruct our vacuum pump oil LVO100.

Use only the kind of oil specified by Leybold.

LVO100 oil	Parts No.
1L	L100 01
5L	L100 05
20L	L100 20
208L	L100 99

NOTICE



1.3 Supplied Equipment

All the pumps are equipped with motors.

For pumps with single-phase AC motor are supplied ready to operate with switch, built-in thermal motor protection switch, mains cable (approx. 1.5 m) and mains plug.

For pumps with three-phase AC motor, the switch, motor protection switch, mains cable etc. are not included.

The equipment supplied with the TRIVAC[®] D4/8T pump includes:

Pump with motor,

1 centering ring,

1 centering ring with dirt trap,

2 clamping rings DN 16 KF,

1 bottle of 1L oil,

Operating Instructions

Spare Parts List

Description

The equipment supplied with the TRIVAC® D16/30T pump includes:
Pump with motor,
1 centering ring,
1 centering ring with dirt trap,
2 clamping rings DN 25 KF,
2 bottle of 1L oil,
Operating Instructions
Spare Parts List

For protection during shipment, the connection ports are each blanked off by rubber diaphragms and supporting rings.

1.4 Accessories

	Cat.No
Oil drain tap	190 90

For D4/8T

Exhaust filter AF8 DN16KF	190 50
Replacement filter element FE8 for AF8 (pack of 5)	ES190 80
Condensate trap AK8 DN16KF	190 60

Exhaust filter AF4-8 DN16KF	189 06
Replacement filter element FE4-8 for AF4-8	189 71
Condensate separator AK4-8 DN16KF	188 06

For D16/30T

Exhaust filter AF25 DN25KF	190 53
Replacement filter element FE25 for AF25 (pack of 5)	ES190 83
Condensate trap AK25 DN25KF	190 63

Exhaust filter AF16-25 DN25KF	189 11
Replacement filter element FE16-25 for AF16-25	189 72
Condensate separator AK16-25 DN25KF	188 11

Connection components required to connect the exhaust filter and the condensate separators in each case:

For D4/8T

1 Pipe bend, DN16KF	184 36
1 Centering ring with O-Ring, DN16KF	182 06
1 Clamping ring, DN16KF	183 41

For D16/30T

1 Pipe bend, DN25KF	184 37
1 Centering ring with O-Ring, DN25KF	182 07
1 Clamping ring, DN25KF	183 42

Remarks: Any other request about accessories, please contact us.

Description

1.5 Technical Data

TRIVAC®	Unit	D4T	D8T	D16T	D30T
Nominal pumping speed (50Hz) ¹⁾	m ³ ·h ⁻¹	5.3	9.2	17.0	31.4
Pumping speed (50Hz) ¹⁾	m ³ ·h ⁻¹	4.4	7.3	14.2	23.9
Ultimate total pressure without gas ballast ¹⁾	mbar	5·10 ⁻³	5·10 ⁻³	5·10 ⁻³	5·10 ⁻³
Ultimate total pressure with gas ballast (pos. 1) ¹⁾	mbar	8·10 ⁻³	8·10 ⁻³	8·10 ⁻³	8·10 ⁻³
Ultimate total pressure with gas ballast (pos. 2) ¹⁾	mbar	2·10 ⁻²	2·10 ⁻²	2·10 ⁻²	2·10 ⁻²
Water vapour tolerance (pos. 2) ¹⁾	mbar	15	15	20	20
Water vapour capacity (pos. 2) ¹⁾	g/h	55	95	230	400
Oil filling, min./max.	l	0.6/0.9	0.7/1	1.0/1.6	1.1/ 1.8
Noise level to DIN 45 635 without/with gas ballast ³⁾	dB (A)	56/58	56/58	58/60	58/60
Ambient temperature ²⁾	°C	12 - 45	12 - 45	12 - 45	12 - 45
Weight without oil	kg	23	24	37	40
Connections, intake and exhaust side	DN (mm)	16KF	16KF	25KF	25KF
Single phase AC motor power ⁴⁾ 100-115V / 210-230V 50Hz 100-115V / 210-230V 60Hz Cat.No. of the pumps deliver with oil LVO100	W	570 660 312 36TE	570 660 312 46TE		
Plug ⁴⁾		230V mains cord 20081091 (1.8m) with Schuko plug CEE 7/7 (included in delivery), 230V mains cord 20081097 (1.8m) with UK plug BS 1363 (optional), 230V mains cord 20081099 (1.8m) with CH plug SEV 1011 (optional), 230V main cord 20081141 (1.8m) with US plug NEMA 6-15P (optional), 115V main cord 20081090 (1.8m) with US plug NEMA 6-15P (optional)		230V mains cord (1.8m) with Schuko plug CEE 7/7 (included in delivery)	
Single phase AC motor power 218-242V 50/60Hz Cat.No. of the pumps deliver with oil LVO100	W			750	750
				312 56TE	312 66TE
3 phase AC motor power YY200-220V/Y380-415V 50Hz & YY200-220V/Y380-480V 60Hz Cat.No. of the pumps deliver with oil LVO100	W	370 440 312 31TE	370 440 312 41TE	750	750
				312 51TE	312 61TE

1) To DIN 28 400 and subsequent numbers; The values are measured by Capacitance Diaphragm Gauge. If using Pirani Gauge, the values will be half or a decade higher. The values are defined by pumps with LVO 100 oil.

2) The motor may accelerate with a delay when simultaneously an undervoltage is present at the motor and the pump is at the minimum permissible and ambient temperature. Under such operating conditions the motor protection switch may respond.

3) The value is measured with 3 phase motor under 50Hz.

4) Cable with Schuko plug CEE 7/7 included in delivery. Cable with other type of plug are optional.

Description

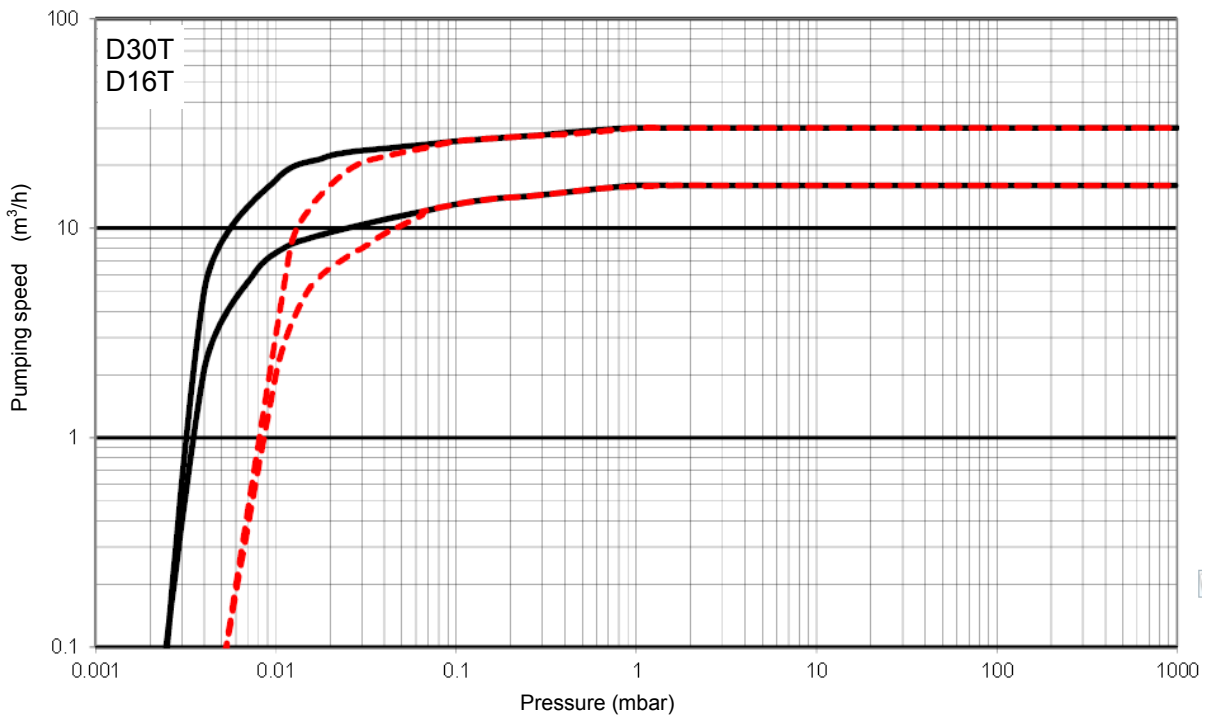
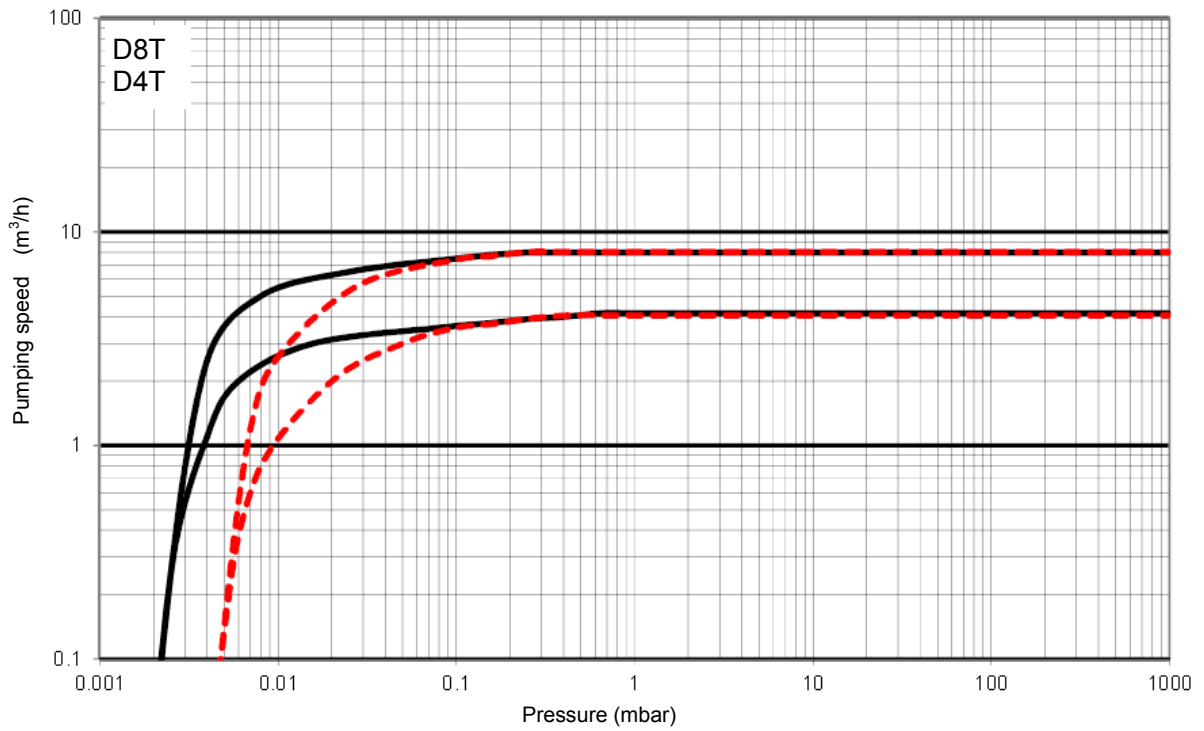

— Ultimate total pressure without gas ballast
 - - - Ultimate total pressure with gas ballast (pos. 1)

Fig. 4 Pumping speed characteristics for the TRIVAC® T pumps (50 Hz operation, SI units)

Description

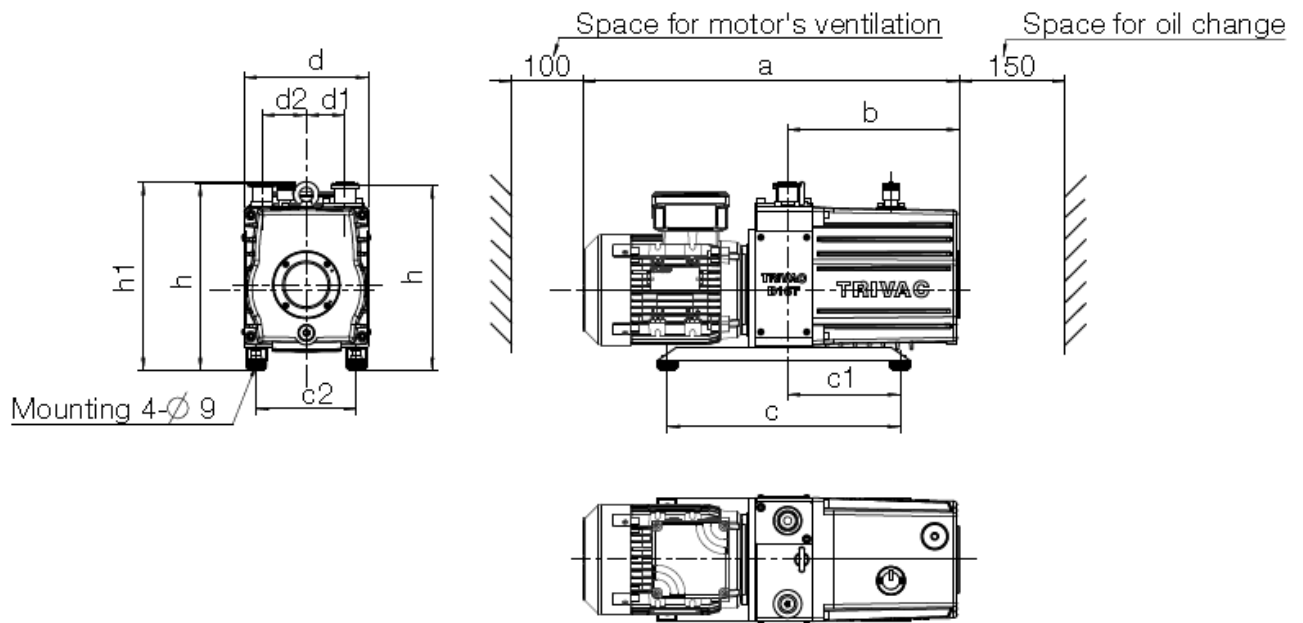

Pump		a	b	c	c1	c2	d	d1	d2	h	h1
D4T	1ph	480					157	41	50	230	247
	3ph	480	190	280	140.5	114	156				240
D8T	1ph	500					157	41	50	230	247
	3ph	500	210	280	140.5	114	156				240
D16T	1ph	565					195	55	63	265	275
	3ph	535	245	330	160	142	185				265
D30T	1ph	610					195	55	63	265	275
	3ph	580	290	330	160	142	185				265

Fig. 5 Dimensional drawing for TRIVAC® T pumps
 (dimensions a, b, c1, d, h and h1 are approximate)
 (dimensions in mm 1inch = 25.4 mm)

Transport and Storing

CAUTION



2 Transport and Storing

To lift the pumps only use the crane eyes provided for this purpose, respectively use corresponding lifting facilities. When connecting or removing the pump, do not move under hoisted loads.

If possible transport the pump in its original packaging, if not available exercise due care.

Pumps which are filled with oil must only be moved while standing upright, otherwise oil may escape. Avoid any other orientations during transport. Check the pump for the presence of any oil leaks, since there exists the danger that someone may slip on spilt oil.

Before putting a pump into operation once more it should be stored in a dry place preferably at room temperature (20 °C). Before the pump is stored it must be properly disconnected from the vacuum system, purged with dry nitrogen and the oil should be changed too.

The inlets and outlets of the pump must be sealed with the shipping seals which are provided upon delivery.

The gas ballast switch must be set to the close position and if the pump is to be stored for a longer period of time it should be sealed in a PE bag containing some desiccant (silica gel).

When a pump is put into operation after it has been stored for over one year, standard maintenance should be run on the pump and the oil should also be exchanged (see Section 5.4). We recommend that you contact the Leybold Service.

3 Installation

Instructions for the operating personnel

Before any kind of assembly work the personnel must be informed about potential hazards. Observe Safety Information 0.1 to 0.6.

3.1 Placement

The TRIVAC® T pump can be set up on a flat, horizontal surface. Rubber feet under the coupling housing ensure that the pump cannot slip.

If you wish firmly install the pump in place, insert bolts through bore holes in the rubber feet.

Risk of toppling

Max. tilt for the pump is 10° from the vertical.

If you wish firmly install the pump in place, insert bolts through bore holes (Ø9mm) in the rubber feet.

The rubber feet act as vibration absorbers. They must therefore not become pressed by screws.

The site chosen should allow adequate air circulation to cool the pump (keep front and rear unobstructed). See Fig.5, Dimensional drawing for TRIVAC® T

The oil-level glass must be visible.

Note the ambient conditions during operation

The ambient temperature should not exceed +45 °C (113 °F) and not drop below +12 °C (55 °F) (see Section 4.3.3).

For installation sites over 1000 m above sea level and/or a relative atmospheric humidity of over 90%, you must discuss this with Technical support or Sales.

The max. amount of heat given off approximately corresponds to the rated motor power.

Install the pump such that only minimal quantities of dust can deposit themselves on the surfaces. In those cases where dust deposits form, measures need to be introduced which ensure that these are removed on a regular basis.

The maximum gas inlet temperature must not exceed 60 °C.

The maximum pressure at the inlet must not exceed atmospheric pressure (approximately 1013 mbar). Never apply overpressures to the pump's inlet.

The maximum exhaust pressure must not exceed 0.5 bar (overpressure).

NOTICE



CAUTION



NOTICE



Installation

3.2 Conforming Utilization

TRIVAC® T pumps can pump gases and vapours, and evacuate vessels or vacuum systems in the fine vacuum range.

The pumps are suited for pumping water vapour within the specified water vapour tolerance limits. Avoid vapours that can condense into liquids when being compressed inside the pump, if these substances exceed the vapour tolerance of the pump. In the case of wet processes we recommend the installation of liquid separators upstream and downstream of the pump as well as the use of the gas ballast.

3.2.1 Non-conforming Utilization

The TRIVAC® T is **NOT** suited for pumping of:

- radioactive and toxic substances
- pyrophorous and explosive substances or gases
- corrosive gases
- oxygen (or other highly reactive gases) at concentrations exceeding that of the atmosphere (> 21 % for oxygen).

CAUTION



NOTICE



CAUTION



Pumping of dust or much contaminated media

The pumps are not suited for pumping of liquids or media which carry large quantities of dust. Corresponding protection devices need to be provided.

The standard pump is not suited for pumping of hazardous gases or vapours.

When cleaning a system in which a TRIVAC® pump has been integrated, all parts in contact with the medium need to be compatible with the cleaning agent so as to prevent a chemical reaction. Residues of the cleaning agent within the pump must be avoided.

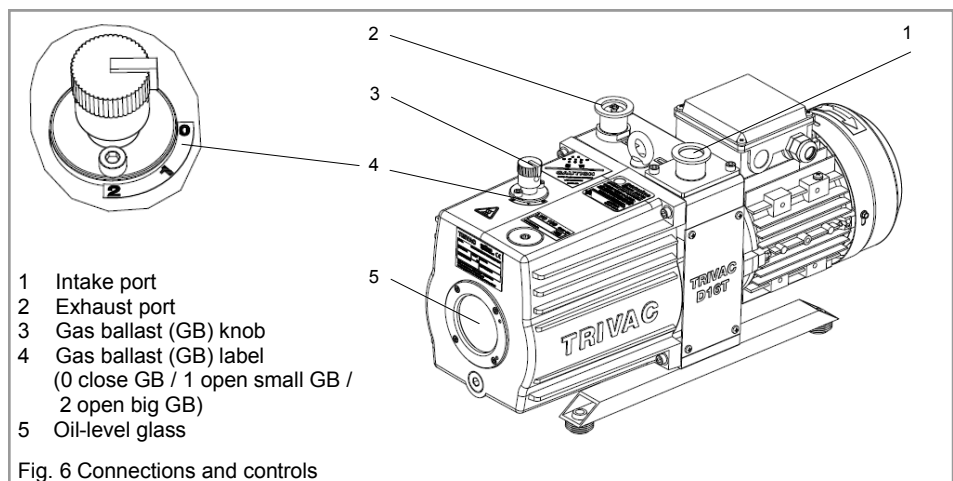

Installation

3.3 Connection to the System

Before connecting the TRIVAC[®] T, remove the shipping seals from the connection flanges (6/1) and (6/2).

Retain the shipping seals in case you need to store the pump in the future.

The pump is shipped with intake and exhaust flanges mounted for vertical connection of the connecting lines. Connect the intake and exhaust lines with a centering ring and a clamping ring each. Use the centering ring with dirt trap for the intake port.

Connect the intake and exhaust line using anti-vibration bellows, without placing any strain on the pump.

The intake line must be clean. Deposits in the intake line may outgas and adversely affect the vacuum. The connecting flanges must be clean and undamaged.

The maximum throughput of the pump is equivalent to the pumping speed of the pump.

Note the specified cross sections for the connection lines

If exhaust gases must be collected or contained, do not allow the exhaust line to become pressurized. The pressure in the oil box must not exceed 1.5 bar (absolute). An exhaust line which is too small in diameter or which is blocked can result in the formation of overpressures within the pump. Possible consequences can damage or even burst open pump. Thus the exhaust line must be checked from time to time to ensure that there are no obstructions. For avoiding of overpressure, you can install the exhaust fan at the end of exhaust pipe or use the short wide exhaust pipe.

If no exhaust line is connected, it is advisable to fit an exhaust filter. If several pumps are connected to one exhaust line, ensure an adequate cross-section and a non-return valve at the exhaust of each pump.

Never operate the pump with a sealed exhaust line. There is the danger of injury.

Avoid back flowing condensate

Install the exhaust line with a downward slope (lower than the pump) so as to prevent condensate from flowing back into the pump. If this is not possible, insert a condensate trap.

CAUTION



NOTICE



Installation

CAUTION



Safely lead the exhaust gases away

Exhaust gases may, depending on the type of application, present a health hazard and/or may be detrimental to the environment.

The exhaust gases from the vacuum pump must be safely led away and subjected to post-treatment as required. In order to reduce the emission of oil vapours we recommend the installation of an additional exhaust filter (Leybold accessory, see Section 1.5). Depending on the type of application or the kind of pumped media, the corresponding regulations and information sheets must be observed.

NOTICE



When oil mist is to be removed from the exhaust flow we recommend the use of the exhaust filter.

The maximum intake pressure must not exceed atmospheric pressure (1013 mbar).

Intake pressure for the gas ballast should be about 1013 mbar (absolute) and sufficient quantities of gas must be available (about 1/10 of the pumping speed).

3.4 Electrical Connections

DANGER



Risk due to high voltages

Death or severe injury caused by an electric shock!

The electrical connections must only be made by a trained electrician as specified, for example, by the regulations EN60204-1. Note the national regulations of the country in which the equipment is being operated.

During all connection work, the mains power supply lines must be deenergised (lockout/tag out). In order to prevent the pump from running up unexpectedly after a mains power failure, the pump must be integrated in the control system in such a way that the pump can only be switched on again manually. This applies equally to emergency cut-out arrangements. Observe Safety Information 0.2.

3.4.1 Pump with Single-Phase AC Motor

With this design, the pump can be directly connected by means of the connecting cable and plug to the corresponding AC mains, using a suitable fuse; refer to the current value stated on the name plate of the motor.

WARNING



The direction of rotation need not be checked as it is fixed. The motor is protected against overloading by a thermal overload switch. After this switch has cut out the motor, the motor is automatically switched back on once it has cooled down. That's why the mains plug must be disconnected from the mains before starting with any work on the pump.

Installation

3.4.2 Pump with Three-Phase AC Motor

TRIVAC® T pumps with three-phase motor are supplied without accessories for electrical connection. They must be connected via the appropriate cable, and a suitable motor protection switch.

If motor protection switch OFF, the motor shut down at once and don't restart automatically. After the motor protection is switched ON manually, the motor can restart automatically on its own. In any case of maintenance either the mains plug has to be disconnected or the motor protection has to be switched OFF before starting with any work on the pump. After the necessary work, the power supply can be rebuilt again.

When operating the unit at its operational limits (at an ambient temperature of 12 °C and at undervoltage, for example) it may be necessary to protect the electric motor against high start-up currents by installing an overload protector (Class 20 in accordance with IEC 60947, for example). Set up according to the information provided on the motor nameplate to meet local requirements for the motor protection switch. The local requirements may specify measures for reducing the start-up current (soft start, frequency controlled start-up, for example).

Set the switch in accordance with the rating on the motor nameplate. Please observe the diagram at the motor. After connecting the motor and after every time you alter the wiring, check the direction of rotation. To do so, briefly switch on the motor and check whether a suitable cover (e. g. a blank flange) is sucked on at the intake port. If not, interchange two phases of the connection. Observe the direction arrow on the motor fan cover. In the case of custom pumps please note the information provided on a separate sheet.

The pump must be sufficiently grounded. Always connect the protective ground conductor in a professional manner and using a single piece of wire.

Warning



NOTICE

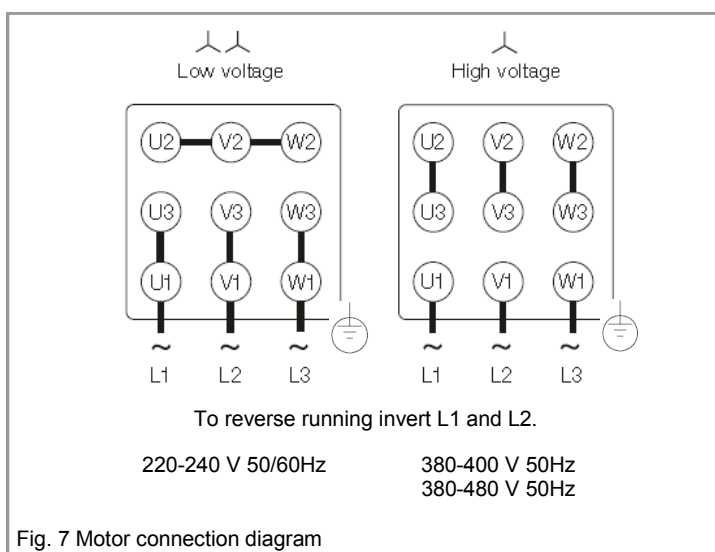

Operation

4 Operation

4.1 Media Compatibility

TRIVAC® T pumps can pump condensable gases and vapours, provided that the gas ballast valve is open and the pump has attained its operating temperature.

4.2 Start-up

Each time before starting up check the oil level. The pump must never be operated with an oil level below the minimum.

Open all valves blocking the exhaust lines. The pump must never be operated with a blocked or constricted exhaust line.

Check the direction of rotation before starting the pump for the first time and after each change in the electrical connection (see Chapter 3.4).

On initial start-up, after prolonged idle periods or after an oil change, the specified ultimate pressure cannot be attained until the oil is degassed.

This can be done by running the pump for approx. 30 min. with the intake line closed and the gas ballast valve (6/4) open.

The TRIVAC® T pump cannot continuously run at operating pressures over than 100 mbar (absolute). It should reach to pressure lower than 100 mbar (absolute) within 20mins.

Use matching accessories only

Before starting the pump ensure that the pump and the fitted accessories meet the requirements of your application and that safe operation can be guaranteed.

Start up the pump only after it has been fully installed

Never operate the pump with an open intake port. Vacuum connections as well as oil feed and discharge openings must not be opened while the pump is operating. Avoid exposing any part of the human body to the vacuum. There is the risk of suffering injury.

Observe Safety Information 0.1.

4.2.1 Start noise

There is start noise which is a little bit bigger than pump running normally when the pump starts in the initial time after stop for a while, especially in the condition of lower ambient temperature. The reason is when the temperature of pump is lower, the viscosity of pump oil is higher so that the vanes can not get out of vane slot of rotor smoothly, which causes start noise. The noise will reduce to normal level after the pump runs normally.

NOTICE



NOTICE



WARNING



WARNING



4.3 Operation

TRIVAC[®] T pumps can pump condensable gases and vapours, provided that the gas ballast valve (6/4) is open and the pump has attained its operating temperature.

If exhaust gases must be collected or contained, do not allow the exhaust line to become pressurised. The pressure in the oil box must not exceed 1.5 bar (absolute). An exhaust line which is too small in diameter or which is blocked can result in the formation of overpressures within the pump.

Possible consequences can be a damaged or even burst open pump.

Thus the exhaust line must be checked from time to time to ensure that there are no obstructions.

4.3.1 Pumping of Non-Condensable Gases and Vapours

If the process contains mainly permanent gases, the TRIVAC[®] T may be operated without gas ballast, provided that the saturation vapour pressure at operating temperature is not exceeded during compression.

If the composition of the gases to be pumped is not known and if condensation in the pump cannot be ruled out, run the pump with the gas ballast valve open and with dry inert gas in accordance with Section 4.3.2.

4.3.2 Pumping of Condensable Gases and Vapours

With the gas ballast valve open and at operating temperature, TRIVAC[®] T pumps can pump pure water vapour up to the water vapour tolerance specified by the technical data. If the vapour pressure increases above the permissible level, the water vapour will condense in the oil of the pump.

When pumping vapours ensure that the gas ballast valve is open and that the pump has been warmed up for approximately 30 minutes with the intake line closed.

Pumping of Vapours

Vapour phases may only be pumped up to the permissible limit after the pump has attained its operating temperature.

During pumping, vapours may dissolve in the oil. This changes the oil properties and thus there is a risk of corrosion in the pump. Therefore, don't switch off the pump immediately after completion of the process.

Instead, allow the pump to continue operating with the gas ballast valve open and the intake line closed until the oil is free of condensed vapours.

We strongly recommend operating the TRIVAC[®] T in this mode for about 30 minutes after completion of the process.

In cyclic operation, the TRIVAC[®] T should not be switched off during the intervals between the individual working phases (power consumption is minimal when the pump is operating at ultimate pressure), but should continue to run with gas ballast valve open and intake port closed (if possible via a valve).

Once all vapours have been pumped off from a process (e.g. during drying), the gas ballast valve can be closed to improve the attainable ultimate pressure.

NOTICE



NOTICE



Operation

4.3.3 Operating Temperature

Proper operation of the TRIVAC[®] T is ensured in the ambient temperature range between 12 °C to 45 °C (55 °F to 113 °F).

At operating temperature, the surface temperature of the TRIVAC[®] T may lie over 70 °C (156 °F).

CAUTION



Beware of hot surfaces

There is the danger of receiving burns.
Observe Safety Information 0.3.

If - due to the ambient conditions - this temperature range is exceeded at either end of the range, contact Leybold Sales.

The motor may accelerate with a delay when simultaneously an under voltage is present at the motor and the pump is at the minimum permissible and ambient temperature.

Under such operating conditions the motor protection switch may respond. In this case the motor may be started again.

4.4 Shutdown

Since the TRIVAC[®] T pump will commonly be exposed to aggressive and corrosive media, we recommend that you let the pump continue to operate even during long non-working intervals (e.g. overnight) with the intake line closed and the gas ballast valve open. This avoids corrosion during idle periods and difficulties when re-starting the pump under conditions where the lubricant has been chemically modified.

CAUTION



When pumping condensable media let the pump continue to operate with the gas ballast valve open and the intake line closed before switching off (see Chapter 4.3.2).

If the TRIVAC[®] T running with mineral oil is to be shutdown for an extended period after pumping aggressive or corrosive media or if the pump has to be stored, proceed as follows:

WARNING



Pump and operating agents may be contaminated

If hazardous substances have been pumped, then these substances can escape from the pump and from the oil. Introduce adequate safety precautions; use gloves, face protection or a respirator, for example. Observe Safety Information 0.4.

Drain the oil (see Chapter 5.4).

Add clean oil until the oil-level is at the "min" mark and let the pump operate for some time.

Then drain the oil and add clean oil until the oil level is at the "max." mark.

Seal the connection ports. Special conservation or anti-corrosion oils aren't necessary.

Please also take note of the information given in Section 2 Transport and Storing.

CAUTION



4.4.1 Controller/Mains Power Failure

In order to prevent the pump from running up unexpectedly after a mains power failure, the pump must be integrated in the control system in such a way that the pump can only be switched on again manually. This applies equally to emergency cut-out arrangements.

5 Maintenance

Danger by High Electric Voltages

Death or severe injury caused by an electric shock!

The electrical connections must only be provided by a trained electrician as specified, for example, by the regulations EN 50110-1. Note the national regulations of the country in which the equipment is being operated.

Disconnect the electrical connections before disassembling the pump. Make absolutely sure that the pump cannot be accidentally started. Observe Safety Information 0.2.

If the pump has pumped harmful substances, contrary to what has been stated in Section 3.2, ascertain the nature of hazard and take adequate safety measures. Observe Safety Information 0.4.

When disposing of used oil, you must observe the applicable environmental regulations!

Due to the design concept, TRIVAC T pumps require very little maintenance when operated under normal conditions. The work required is described in the sections below. In addition to this, a maintenance plan is provided in Section 5.1.

All work must be carried out by suitably trained personnel. Maintenance or repairs carried out incorrectly will affect the life and performance of the pump and will void any warranty claims.

Leybold offers practical courses on the maintenance, repair, and testing of TRIVAC® T pumps. Further details are available from Leybold on request.

If the TRIVAC® T is used in ambient air which is much contaminated, make sure that the air circulation and the gas ballast valve are not adversely affected.

When the TRIVAC® T has been pumping corrosive media we recommend that possibly planned maintenance work be carried out immediately in order to prevent corrosion of the pump while it is at standstill.

In case of special designs and variants please always indicate the serial number.

DANGER



NOTICE



NOTICE



Maintenance

5.1 Maintenance Plan

No.	Rotary vane pumps Trivac D4T Trivac D8T Trivac D16T Trivac D30T	Measurement / test quantity Operating / auxiliary materials	Interval						Remarks
			VE	VP	t	6m	a	n-a	
					×				Refer also to the Operating Instructions - Section: individual components.
1	Operate the pump for at least 1 hours with gas ballast.				×				Condensed water is thus removed from the oil.
2	Check the oil level, change the oil if required.	Oil: LVO100 or special and alternative oils, see Chapter 1.2	×		×				Refill: only after the pump has been switched off.
3	Check the quality of the oil, change the oil if required.	visually (all oils)	×		×				Visually: normally light and transparent, oil change is required when discolorations increase.
		chemically				×			Chemically: to DIN 51558 when the neutralization number exceeds 2; then an oil change will be required.
		mechanically				×			Mechanically: when dynamic viscosity at 25 °C exceeds 300 mPas; then an oil change will be required.
4	Clean the dirt trap in the intake port, change it as required.	Suitable cleaning agent and compressed air				×			<ul style="list-style-type: none"> ■ Clean dirt trap with a cleaning agent and blow it out with compressed air under a suction hood. ■ Replace the defective dirt trap. Use a cleaning agent which complies with the national / international specifications. Observe the safety regulations when using cleaning agents
5	Check the edges of the teeth on the coupling element for any damages, change the coupling element as required.							×	
6	Change the oil - and	Oil: LVO100						×	Oil change: <ul style="list-style-type: none"> ■ First oil change after 100 operating hours ■ Pump switched off and cold. Change the oil when the pump is cold in order to avoid releasing absorbed gases.
	clean the oil level glass.	Suitable cleaning agent and compressed air.							Clean the oil level glass with a cleaning agent and blow it out with compressed air under a suction hood. Cleaning agent according to national / international specifications. Observe the safety regulations when using cleaning agents. Quantity of oil: see Operating Instructions, Section 1.6.
7	Check the fan of the pump and the motor as well as the cooling fins on the motor for deposits and clean as required.	Brush and industrial vacuum cleaner.						×	Already clean before the maintenance interval has elapsed when the pump or the motor gets to warm. Caution: switch off the pump and ensure that it can not run up inadvertently (disconnect from the mains).

Key to the maintenance plan

VE = Maintenance before switching on the system
 VP = Maintenance before starting production
 t = Daily maintenance
 6m = Six monthly maintenance
 a = Annual maintenance
 n-a = Maintenance every n years

We recommend that you service the pump every two years concerning the following:

- Cleaning
- Checking of the individual components
- Exchange of all seals
- Function check

This check should be run by the Leybold service.

Maintenance

5.2 Leybold Service

Whenever you send a pump to Leybold, indicate whether the pump is contaminated or is free of substances which could pose a health hazard. If it is contaminated, specify exactly which substances are involved.

You must use the form we have prepared for this purpose; we will forward the form on request.

A copy of the form is printed at the end of these operating instructions: „Declaration of contamination of vacuum equipment and components“.

Another suitable form is available from the Leybold home-page:

www.leybold.com → Downloads → Download Documents → Declaration of Contamination

Connect the form at the device or lay it to the device.

This statement detailing the contamination is required to satisfy legal requirements and for the protection of our employees.

Pumps which are not accompanied by a contamination statement will be returned to the sender.

Use secure shipping packaging

Package the pump such that it will not suffer any damage when being shipped and so that no oil or hazardous materials can escape from the packaging.

CAUTION



Maintenance

5.3 Monitoring the Oil Level

During operation of the TRIVAC[®] T the oil level must always remain between marks (8/2) and (8/3) on the oil-level glass. The amount of oil must be checked and topped up as required.

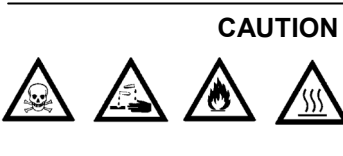

Check and top up oil only after having shut down the pump first.

Please note the safety information given in Section 0.3 und 0.4.

Pumps which have not directly been delivered from Leybold, e.g. in systems, may have been filled with oils different from LVO100. In this case a refill with LVO100 may cause problems. Therefore check before the refill the kind of oil in the pump and fill in only suitable oil or change the oil.

When operating the TRIVAC[®] T in connection with the exhaust filter with lubricant return the checking intervals are extended.

5.3.1 Checking the Condition of the Oil

The ageing process for the standard operating fluid LVO100 respectively (see Section 1.2) will depend very much on the area of application for the pump.

There exist the following ways of checking the oil:

a) Visual check

Normally the oil is clear and transparent. If the oil darkens, it should be changed.

b) Chemical check

The neutralisation number of LVO 100 oil is determined according to DIN 51558. If it exceeds 2, the oil should be changed.

c) Viscosity check

If the viscosity of LVO 100 at 25 °C exceeds a level of 240 mPas (20 % higher than the viscosity of fresh oil) an oil change is recommended.

If gases or liquids dissolved in the oil result in a deterioration of the ultimate pressure, the oil can be degassed by allowing the pump to run for approx. 30 min. with the intake port closed and the gas ballast valve open.

When wanting to check the oil, switch off the pump first and drain out from the warm pump the required amount of oil through the oil drain (9/4) into a beaker or similar.

Please note the safety information given in Section 5.4.

5.4 Oil Change

Pump and operating agents may be contaminated

Hazardous substances may escape from the pump and the oil. If there is the danger that the operating agent may present a hazard in any way due to decomposition of the oil, or because of the media which have been pumped, you must determine the kind of hazard and ensure that all necessary safety precautions are taken. Use gloves, face protection or a respirator, for example.

Observe Safety Information 0.3 und 0.4.

Change the oil while the pump is cold so as to avoid releasing adsorbed gases. If releasing adsorbed gases is no problem, change the oil after the pump has been switched off and while the pump is still warm.

Risk of suffering burns

With the pump warm from operation, both pump and oil can get so hot that there is the risk of suffering burns. If required, wear gloves.

Check and top up oil only after having shut down the pump first.

When disposing of waste oil, observe the applicable environment protection regulations!

When changing the oil use the same type of oil which was previously in the pump. If you want to change the type of oil entirely please consult us first.

The oil should be changed after the first 100 operating hours and then at least every 2000 - 3000 operating hours or after one year. At high intake pressures and intake temperatures and/or when pumping contaminated gases, the oil will have to be changed much more frequently.

Further oil changes should be made before and after long-term storage of the pump.

If the oil becomes contaminated too quickly, contact us for more support information .

WARNING



NOTICE



Maintenance

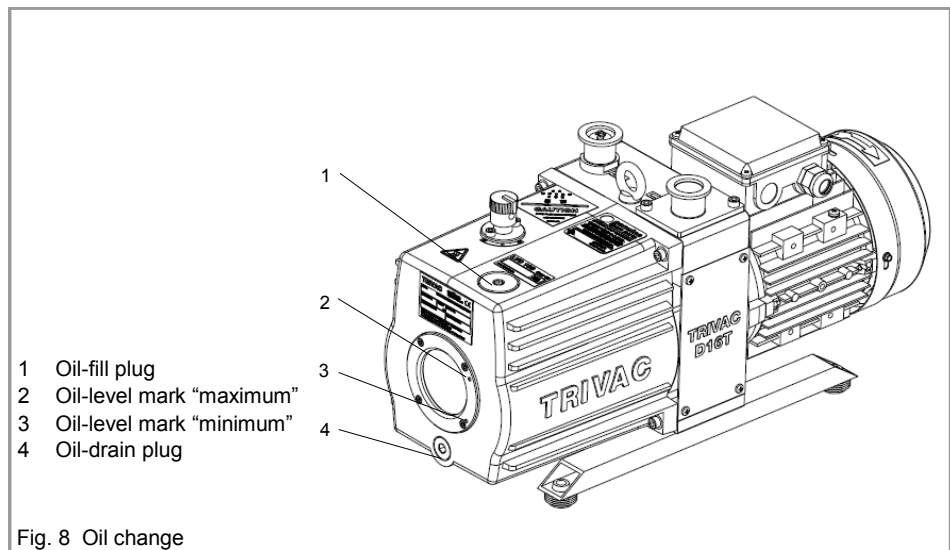

Required tool: Allen key 8 mm.

Remove the oil-drain plug (8/4) and let the used oil drain into a suitable container.

When the flow of oil slows down, screw the oil-drain plug back in, briefly switch on the pump (max. 10 s) and then switch it off again. Remove the oil-drain plug once more and drain out the remaining oil.

Screw the oil-drain plug back in (check the gasket and reinstall a new one if necessary).

Remove the oil-fill plug (8/1) and fill in fresh oil.

Screw the oil-fill plug (8/1) back in.

When an exhaust filter with lubricant return has been installed on the pump please also exchange the oil there.

NOTICE



We can only guarantee that the pump operates as specified by the technical data if the lubricants recommended by us are used.

5.5 Cleaning the Inlet Screen

A wire-mesh sieve is located in the intake port of the pump to act as a dirt trap for foreign objects. It should be kept clean to avoid a reduction of the pumping speed.

For this purpose, remove the dirt trap (1/2) from the intake port and rinse it in a suitable vessel with solvent. Then thoroughly dry it with compressed air.

If the dirt trap is defective, replace it with a new one.

NOTICE



The cleaning intervals depend on the application. If the pump is exposed to large amounts of abrasive materials, a dust filter should be fitted into the intake line.

5.6 Disassembly and Reassembly of the Electric Motor

Risk due to high voltages

Death or severe injury caused by an electric shock!

Before starting work, always disconnect the motor from the mains. Pull the mains plug. Observe Safety Information 0.2.

DANGER

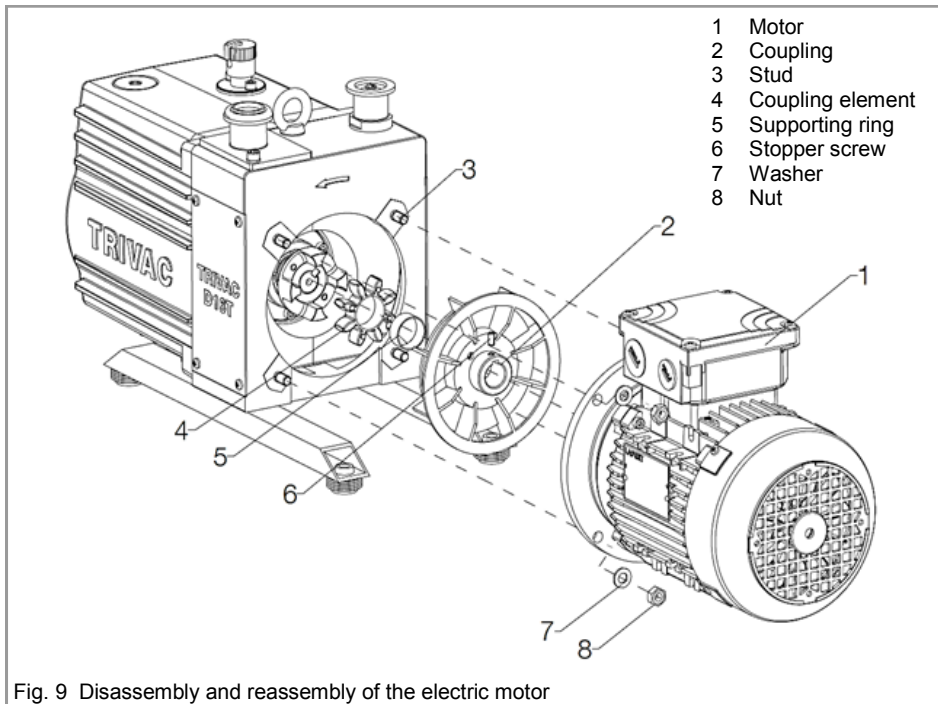

Fig. 9 Disassembly and reassembly of the electric motor

Required tools:

Motor terminal box: Cross screwdriver 2#

Inside of terminal box: Terminal board, box wrench 7mm; Grounding, Cross screwdriver 2#;

Motor connection: Open end wrench 13mm (D16/30T) / 10mm (D4/8T)

Stopper screw for coupling: Allen key 2.5mm, possibly a puller for the coupling.

Disconnect the mains connection.

Support the motor.

Unscrew the screws (9/8).

Remove the electric motor (9/1).

Loosen the stopper screw (9/6) and pull the coupling (D16/30T coupling with the blade wheel) (9/2) off the motor shaft using puller if necessary.

Clean all parts and check that they are in perfect condition; if not, replace them with new parts.

Reassemble in the reverse order.

5.6.1 Checking the Coupling

Here the backlash between coupling cams and coupling element (9/4) must be checked by a feeler gauge (see sketch 1).

When reaching the limit of wear of max. friction, the coupling element must be exchanged immediately, independent of the inspection intervals.

The wear limit is at 3mm!

In addition a visual inspection as to the presence of any damage needs to be done. If damaged, the coupling must be replaced.

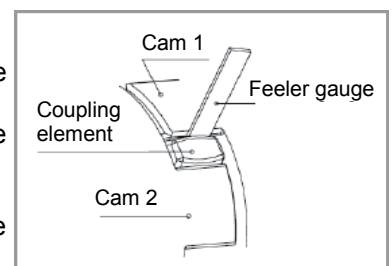

Sketch 1 Checking the wear limit

Maintenance

5.7 Maintaining the Gas Ballast Valve

D16/30T:

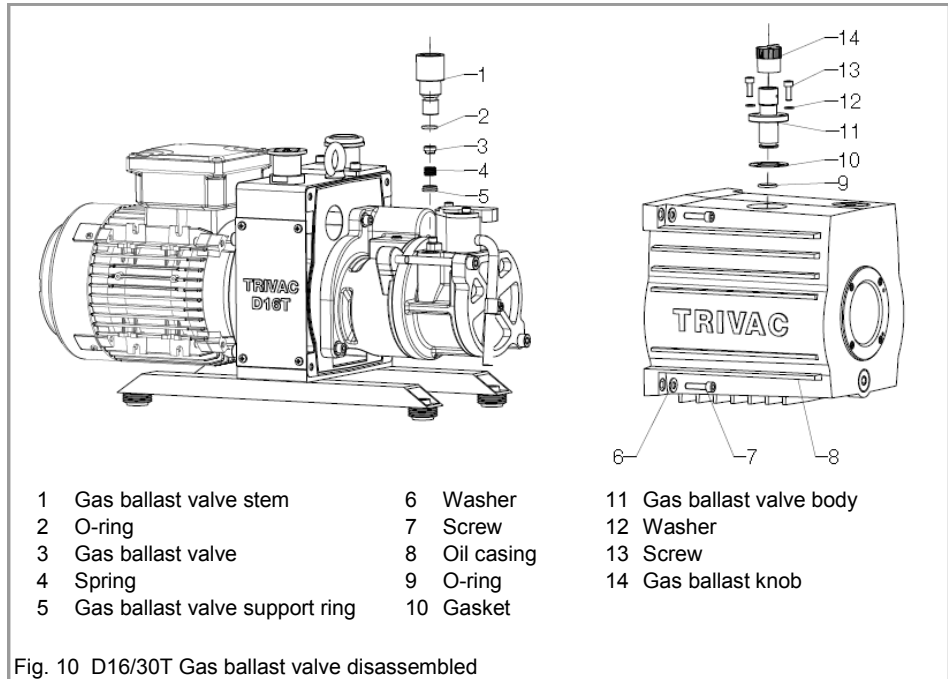

Fig. 10 D16/30T Gas ballast valve disassembled

Tools required:
Allen key 4 mm
Allen key 5 mm

Unscrew the two hex head screws (10/13);
Remove the gas ballast valve body (10/11);
Take off the gasket (10/10) and O-ring (10/9);
Clean the parts and check that they are in perfect condition; If not, replace them.

Unscrew the four hex head screws (10/7);
Remove the oil casing (10/8);
Pull out the gas ballast valve stem (10/1);
Take off the O-ring (10/2);
Clean the parts and check that they are in perfect condition; If not, replace them.

Pull out the gas ballast valve support ring (10/5);
Take off the spring (10/4) and gas ballast valve (10/3);
Clean the parts and check that they are in perfect condition; If not, replace them.

Remount In the reverse order.
Ordering number of Gas Ballast Valve kit can be found in spare parts list.

Maintenance

D4/8T:

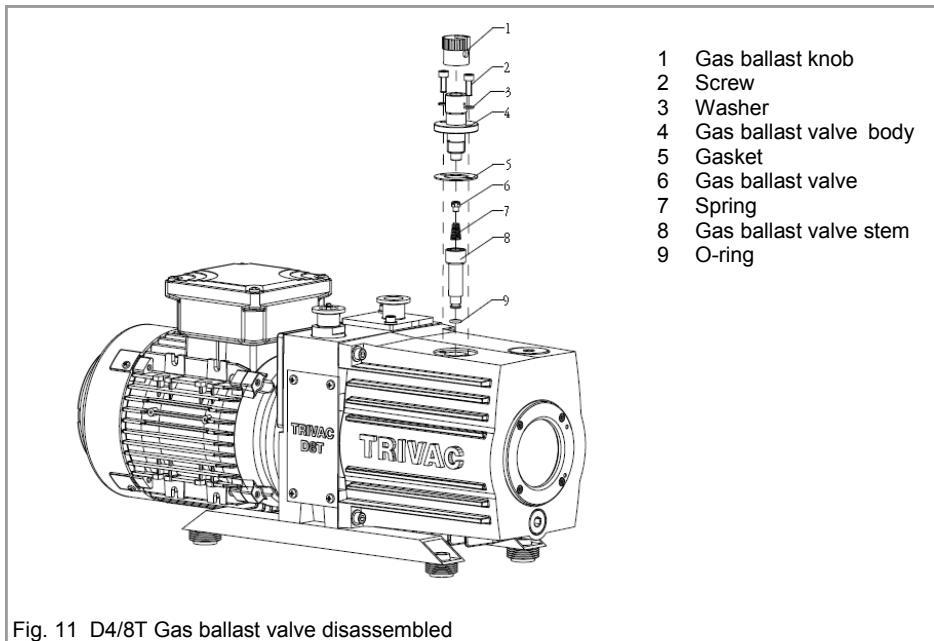

Fig. 11 D4/8T Gas ballast valve disassembled

Tools required:
Allen key 4 mm

Unscrew the two hex head screws (11/2);
Remove the complete gas ballast unit (11/1~9);
Take off the gasket (11/5) and O-ring (11/9);
Clean the parts and check that they are in perfect condition; If not, replace them.

Disassemble the gas ballast valve body (11/4) and gas ballast valve stem (11/8) using grip wrench;
Take of the spring (11/7) and non-return valve (11/6);
Clean the parts and check that they are in perfect condition; If not, replace them.

Remount In the reverse order.
Ordering number of Gas Ballast Valve kit can be found in spare parts list.

Troubleshooting

6 Troubleshooting

Fault	Possible cause	Remedy	Repair *
Pump does not start.	Wiring is malfunctioning.	Check and repair wiring.	-
	Motor protection switch incorrectly set (three-phase motors only).	Set motor protection switch properly.	3.4
	Operating voltage does not match motor.	Replace the motor.	5.6
	Motor is malfunctioning.	Replace the motor.	5.6
	Oil temperature is below 12°C.	Heat the pump and pump oil or use different oil.	4.3.3/5.4
	Oil is too viscous.	Change the oil.	5.4
	Exhaust filter or exhaust line is clogged.	Replace the filter or clean the exhaust line.	-
	Pump is seized up (sign: pump is jammed).	Repair the pump.	Service
Pump does not reach ultimate pressure.	Measuring technique or gauge is unsuitable.	Use correct measuring technique and gauge. Measure the pressure directly at pump's intake port.	-
	External leak ¹⁾ .	Repair the pump.	Service
	Anti-suck back valve is malfunctioning.	Repair the valve.	Service
	Exhaust valve is malfunctioning.	Repair the valve.	Service
	Oil is unsuitable.	Change the oil (degas it, if necessary).	5.4
	Vacuum lines are dirty.	Clean vacuum lines.	-
Pumping speed is too low.	Pump is too small.	Check the process data; replace the pump, if necessary.	-
	Inlet screen in the intake port is clogged.	Clean the dirt trap; Precaution: install a dust filter in intake line.	5.5
	Exhaust filter is clogged.	Exchange the filter element.	-
After switching off pump under vacuum, pressure in system rises too fast.	Connecting lines are too narrow or too long.	Use adequately wide and short connecting lines.	3.3
	System has a leak.	Check the system.	-
	Anti-suck back valve is malfunctioning.	Repair the valve.	Service
	Pump gets hotter than usually observed.	Cooling air supply is obstructed.	Set pump up correctly.
Ambient temperature is too high.		Set pump up correctly.	3.1/4.3.3
Process gas is too hot.		Change the process.	-
Oil level is too low.		Add oil.	5.3
Oil is unsuitable.		Change the oil.	5.4
Oil cycle is obstructed.		Clean or repair the oil lines and channels.	Service
Exhaust filter or exhaust line is obstructed.		Replace the exhaust filter, clean the exhaust line.	-
	Exhaust valve is malfunctioning.	Repair the valve.	Service
	Pump module is worn out.	Replace the pump module.	Service
Oil in the intake line or in vacuum vessel.	Oil comes from the vacuum system.	Check the vacuum system.	-
	Anti-suck back valve is obstructed.	Clean or repair the valve.	Service
	Sealing surfaces of anti-suck back valve are damaged or dirty.	Clean or repair the intake port and the anti-suck back valve.	Service
	Oil level is too high.	Drain the excess oil.	5.3
Oil is turbid.	Condensation.	Degas the oil or change the oil and clean the pump. Precaution: open the gas ballast valve or fit separator.	4.3.2/5.4
Pump is excessively noisy.	Oil level is much too low (oil is no longer visible).	Add oil.	5.3/5.4
	Silencing nozzle is clogged.	Clean or replace the silencing nozzle.	Service
	Intake pressure is too high.	Lower the intake pressure.	-
	Internal demister is clogged.	Clean or replace demister.	Service
	Coupling element is worn.	Install new coupling element.	-
	Vanes or bearings are damaged.	Repair pump.	Service

*Repair: Refer to the stated section in these Operating Instructions.

1) Bubble test: The warm pump with degassed oil is running without gas ballast and the intake is blanked off. The exhaust line is led into a vessel with water. If an evenly spaced line of bubbles appears then the pump has an external leak.

Spare Parts

7 Wearing Parts and Original Spare Parts

To guarantee safe operation of the Leybold vacuum pump, only original spare parts and accessories should be used. When ordering spare parts and accessories, always state pump type and serial number. You can find part numbers in the spare parts list.

Consumables and main spare parts kits for TRIVAC® T pumps are usually available on stock at Leybold's service centers. The spare parts for your vacuum pump are listed in the spare part list enclosed with product.

We recommend to use these kits which have been defined to allow an optimal maintenance or repair. Individual spare parts may need longer delivery time.

8 Waste Disposal

The equipment may have been contaminated by the process or by environmental influences. In this case the equipment must be decontaminated in accordance with the relevant regulations. We offer this service at fixed prices. Further details are available on request.

Risk of injury and environmental damage

Contaminated parts can be detrimental to health and environment. Before beginning with any work, first find out whether any parts are contaminated.

Adhere to the relevant regulations and take the necessary precautions when handling contaminated parts; For example wear gloves, face protection or breathing protection.

WARNING



Separate clean components according to their materials, and dispose of these accordingly. We offer this service. Further details are available on request.

When sending us any equipment, observe the regulations given in Section "5.2 Leybold Service".

Disposal of Waste Oil

Owners of waste oil are entirely self-responsible for proper disposal of this waste.

Waste oil from vacuum pumps must not be mixed with other substances or materials.

Waste oil from vacuum pumps (Leybold oils which are based on mineral oils) which are subject to normal wear and which are contaminated due to the influence of oxygen in the air, high temperatures or mechanical wear must be disposed of through the locally available waste oil disposal system.

Waste oil from vacuum pumps which is contaminated with other substances must be marked and stored in such a way that the type of contamination is apparent. This waste must be disposed of as special waste.

European, national and regional regulations concerning waste disposal need to be observed. Waste must only be transported and disposed of by an approved waste disposal vendor.

EU Declaration of Conformity

(Original Declaration of Conformity)

The manufacturer: Leybold GmbH
Bonner Strasse 498
D-50968 Köln
Germany

herewith declares that the products specified and listed below which we have placed on the market, comply with the applicable EU Directives. This declaration becomes invalid if modifications are made to the product without agreement of Leybold GmbH.

Product designation: Dual-stage Oil-sealed Rotary Vane Vacuum Pump
Type designation: Trivac[®] T D4T, D8T, D16T, D30T
Part numbers: 31231TE, 31236TE, 31241TE, 31246TE,
31251TE, 31256TE, 31261TE, 31266TE

The products complies to the following Directives:

Machinery Directive (2006/42/EC)

The safety objectives of the Low Voltage Directive 2014/35/EU were complied with in accordance with Appendix 1 No. 1.5.1 of Machinery Directive 2006/42/EC.

Electromagnetic Compatibility (2014/30/EU)

RoHS Directive (2011/65/EU)

The following harmonized standards have been applied:

EN 1012-2:1996+A1:2009	Compressors and vacuum pumps - Safety requirements Part 2: Vacuum pumps
EN 60204-1:2006	Safety of machinery - Electrical equipment of machines Part1: General requirements
EN 61000-6-2:2005/AC:2005	Electromagnetic compatibility (EMC) - Part 6-2: Generic standards - Immunity for industrial environments
EN 61000-6-4:2007/A1:2011	Electromagnetic compatibility (EMC) - Part 6-4: Generic standards - Emission standard for industrial environments
EN 50581:2012	Technical documentation for the assessment of electrical and electronic products with respect to the restriction of hazardous substances

Documentation officer: Herbert Etges
T: +49(0)221 347 0
F: +49(0)221 347 1250
documentation@leybold.com

Cologne, September 01, 2016

Cologne, September 01, 2016

ppa. Martin Tollner
VP / Head of Product Lines
ppa. Dr. Monika Mattern-Klosson
Head of Quality & Business Process Management

Safety information

On contamination of compressors, vacuum pumps and components.

Scope

Every employer (user) is held responsible for the health and safety of his employees. This also applies to service personnel performing maintenance work either at the premises of the user or the service company in-charge.

By means of the declaration attached the contractor is to be informed about any possible contamination of the compressor, vacuum pump or component sent in for servicing. Based on this information the contractor will be able to take the necessary safety precautions.

Preparation before dispatch

Before shipping any parts, the user must complete the following declaration and add it to the dispatch papers. All dispatch instructions laid down in the manual must be followed e.g.:

- Drain all service fluids
- Remove filter elements
- Seal all openings airtight
- Pack/handle appropriately
- Attach the declaration of contamination **outside** of the packaging

Declaration of Contamination of Compressors, Vacuum Pumps and Components

The repair and / or servicing of compressors, vacuum pumps and components will be carried out only if a correctly completed declaration has been submitted. Non-completion will result in delay. The manufacturer can refuse to accept any equipment without a declaration.

A separate declaration has to be completed for each single component.

This declaration may be completed and signed only by authorized and qualified staff.

Customer/Dep./Institute : _____ Address : _____ _____ Person to contact: _____ Phone : _____ Fax: _____ End user: _____	Reason for return: <input checked="" type="checkbox"/> applicable please mark Repair: <input type="checkbox"/> chargeable <input type="checkbox"/> warranty Exchange: <input type="checkbox"/> chargeable <input type="checkbox"/> warranty <input type="checkbox"/> Exchange already arranged / received Return only: <input type="checkbox"/> rent <input type="checkbox"/> loan <input type="checkbox"/> for credit Calibration: <input type="checkbox"/> DKD <input type="checkbox"/> Factory-calibr. <input type="checkbox"/> Quality test certificate DIN 55350-18-4.2.1																				
A. Description of the Leybold product: Material description : _____ Catalog number: _____ Serial number: _____ Type of oil (ForeVacuum-Pumps) : _____	Failure description: _____ Additional parts: _____ Application-Tool: _____ Application- Process: _____																				
B. Condition of the equipment																					
<table border="1" style="width: 100%; border-collapse: collapse;"> <thead> <tr> <th style="width: 40%;"></th> <th style="width: 10%; text-align: center;">No¹⁾</th> <th style="width: 10%; text-align: center;">Yes</th> <th style="width: 10%; text-align: center;">No</th> </tr> </thead> <tbody> <tr> <td>1. Has the equipment been used</td> <td style="text-align: center;"><input type="checkbox"/></td> <td style="text-align: center;"><input type="checkbox"/></td> <td style="text-align: center;"><input type="checkbox"/></td> </tr> <tr> <td>2. Drained (Product/Service fluid)</td> <td style="text-align: center;"><input type="checkbox"/></td> <td style="text-align: center;"><input type="checkbox"/></td> <td style="text-align: center;"><input type="checkbox"/></td> </tr> <tr> <td>3. All openings sealed airtight</td> <td style="text-align: center;"><input type="checkbox"/></td> <td style="text-align: center;"><input type="checkbox"/></td> <td style="text-align: center;"><input type="checkbox"/></td> </tr> <tr> <td>4. Purged</td> <td style="text-align: center;"><input type="checkbox"/></td> <td style="text-align: center;"><input type="checkbox"/></td> <td style="text-align: center;"><input type="checkbox"/></td> </tr> </tbody> </table> If yes, which cleaning agent _____ and which method of cleaning _____ ¹⁾ If answered with "No", go to D.		No ¹⁾	Yes	No	1. Has the equipment been used	<input type="checkbox"/>	<input type="checkbox"/>	<input type="checkbox"/>	2. Drained (Product/Service fluid)	<input type="checkbox"/>	<input type="checkbox"/>	<input type="checkbox"/>	3. All openings sealed airtight	<input type="checkbox"/>	<input type="checkbox"/>	<input type="checkbox"/>	4. Purged	<input type="checkbox"/>	<input type="checkbox"/>	<input type="checkbox"/>	Contamination : toxic <input type="checkbox"/> <input type="checkbox"/> corrosive <input type="checkbox"/> <input type="checkbox"/> flammable <input type="checkbox"/> <input type="checkbox"/> explosive ²⁾ <input type="checkbox"/> <input type="checkbox"/> radioactive ²⁾ <input type="checkbox"/> <input type="checkbox"/> microbiological ²⁾ <input type="checkbox"/> <input type="checkbox"/> other harmful substances <input type="checkbox"/> <input type="checkbox"/>
	No ¹⁾	Yes	No																		
1. Has the equipment been used	<input type="checkbox"/>	<input type="checkbox"/>	<input type="checkbox"/>																		
2. Drained (Product/Service fluid)	<input type="checkbox"/>	<input type="checkbox"/>	<input type="checkbox"/>																		
3. All openings sealed airtight	<input type="checkbox"/>	<input type="checkbox"/>	<input type="checkbox"/>																		
4. Purged	<input type="checkbox"/>	<input type="checkbox"/>	<input type="checkbox"/>																		
C. Description of processed substances (Please fill in absolutely) 1. What substances have come into contact with the equipment ? Trade name and /or chemical term of service fluids and substances processed, properties of the substances According to safety data sheet (e.g. toxic, inflammable, corrosive, radioactive) <table border="1" style="width: 100%; border-collapse: collapse;"> <thead> <tr> <th style="width: 10%; text-align: center;">X</th> <th style="width: 40%;">Tradename:</th> <th style="width: 50%;">Chemical name:</th> </tr> </thead> <tbody> <tr> <td style="text-align: center;">a)</td> <td>_____</td> <td>_____</td> </tr> <tr> <td style="text-align: center;">b)</td> <td>_____</td> <td>_____</td> </tr> <tr> <td style="text-align: center;">c)</td> <td>_____</td> <td>_____</td> </tr> <tr> <td style="text-align: center;">d)</td> <td>_____</td> <td>_____</td> </tr> </tbody> </table>		X	Tradename:	Chemical name:	a)	_____	_____	b)	_____	_____	c)	_____	_____	d)	_____	_____					
X	Tradename:	Chemical name:																			
a)	_____	_____																			
b)	_____	_____																			
c)	_____	_____																			
d)	_____	_____																			
2. Are these substances harmful? <input type="checkbox"/> No <input type="checkbox"/> Yes 3. Dangerous decomposition products when heated? <input type="checkbox"/> No <input type="checkbox"/> Yes If yes, which? _____																					
²⁾ Components contaminated by microbiological, explosive or radioactive products/substances will not be accepted without written evidence of decontamination.																					

D. Legally binding declaration

I / we hereby declare that the information supplied on this form is accurate and sufficient to judge any contamination level.

Name of authorized person (block letters) : _____ _____ Date _____	_____ signature of authorized person	firm stamp
--	---	------------

Sales and Service

Germany

Leybold GmbH
Sales, Service, Support Center (3SC)
Bonner Strasse 498
D-50968 Cologne
T: +49-(0)221-347 1234
F: +49-(0)221-347 31234
sales@leybold.com
www.leybold.com

Leybold GmbH
Sales Area North
Branch Office Berlin
Industriestrasse 10b
D-12099 Berlin
T: +49-(0)30-435 609 0
F: +49-(0)30-435 609 10
sales.bn@leybold.com

Leybold GmbH
Sales Office South
Branch Office Munich
Karl-Hammerschmidt-Strasse 34
D-85609 Aschheim-Dornach
T: +49-(0)89-357 33 9-10
F: +49-(0)89-357 33 9-33
sales.mn@leybold.com
service.mn@leybold.com

Leybold Dresden GmbH
Service Competence Center
Zur Wetterwarte 50, Haus 304
D-01109 Dresden
Service:
T: +49-(0)351-88 55 00
F: +49-(0)351-88 55 041
info.dr@leybold.com

Europe

Belgium

Leybold Nederland B.V.
Belgisch bijkantoor
Leuvensesteenweg 542-9A
B-1930 Zaventem
Sales:
T: +32-2-711 00 83
F: +32-2-720 83 38
sales.zv@leybold.com
Service:
T: +32-2-711 00 82
F: +32-2-720 83 38
service.zv@leybold.com

France

Leybold France S.A.S.
Parc du Technopolis, Bâtiment Beta
3, Avenue du Canada
F-91940 Les Ulis cedex
Sales and Service:
T: +33-1-69 82 48 00
F: +33-1-69 07 57 38
info.ctb@leybold.com
sales.ctb@leybold.com

Leybold France S.A.S.
Valence Factory
640, Rue A. Bergès
B.P. 107
F-26501 Bourg-lès-Valence Cedex
T: +33-4-75 82 33 00
F: +33-4-75 82 92 69
marketing.vc@leybold.com

Great Britain

Leybold UK LTD.
Unit 9
Silverglade Business Park
Leatherhead Road
Chessington
Surrey (London)
KT9 2QL
Sales:
T: +44-13-7273 7300
F: +44-13-7273 7301
sales.ln@leybold.com
Service:
T: +44-13-7273 7320
F: +44-13-7273 7303
service.ln@leybold.com

Italy

Leybold Italia S.r.l.
Via Trasimeno 8
I-20128 Mailand
Sales:
T: +39-02-27 22 31
F: +39-02-27 20 96 41
sales.mi@leybold.com
Service:
T: +39-02-27 22 31
F: +39-02-27 22 32 17
service.mi@leybold.com

Netherlands

Leybold Nederland B.V.
Floridadreef 102
NL-3565 AM Utrecht
Sales and Service:
T: +31-(30) 242 63 30
F: +31-(30) 242 63 31
sales.ut@leybold.com
service.ut@leybold.com

Switzerland

Leybold Schweiz AG, Pfäffikon
Churerstrasse 120
CH-8808 Pfäffikon
Warehouse and shipping address:
Riedthofstrasse 214
CH-8105 Regensdorf
Sales:
T: +41-44-308 40 50
F: +41-44-302 43 73
sales.zh@leybold.com
Service:
T: +41-44-308 40 62
F: +41-44-308 40 60
service.zh@leybold.com

Spain

Leybold Spain, S.A.
C/ J. Huelva, 7
E-08940 Cornellà de Llobregat
(Barcelona)
Sales:
T: +34-93-666 43 11
F: +34-93-666 43 70
sales.ba@leybold.com
Service:
T: +34-93-666 46 11
F: +34-93-685 43 70
service.ba@leybold.com

Headquarter

Leybold GmbH
Bonner Strasse 498
D-50968 Koeln
T: +49-(0)221-347 0
F: +49-(0)221-347 1250
info@leybold.com

America

USA

Leybold USA Inc.
5700 Mellon Road
USA-Export, PA 15632
T: +1-724-327-5700
F: +1-724-325-3577
info.ex@leybold.com
Sales:
T: +1-724-327-5700
F: +1-724-333-1217
Service:
T: +1-724-327-5700
F: +1-724-325-3577

Brazil

Leybold do Brasil
Rod. Vice-Prefeito Hermenegildo Tonolli,
No. 4413 - 6B
Distrito Industrial
Jundiaí - SP
CEP 13.213-086
Sales and Service:
T: +55 11 3395 3180
F: +55 11 99467 5934
sales.ju@leybold.com
service.ju@leybold.com

Asia

P. R. China

Leybold (Tianjin)
International Trade Co. Ltd.
Beichen Economic
Development Area (BEDA),
No. 8 Western Shuangchen Road
Tianjin 300400
China
Sales and Service:
T: +86-22-2697 0808
F: +86-22-2697 4061
F: +86-22-2697 2017
sales.tj@leybold.com
service.tj@leybold.com

India

Leybold India Pvt Ltd.
No. 82(P), 4th Phase
K.I.A.D.B. Plot
Bommasandra Industrial Area
Bangalore - 560 099
Indien
Sales and Service:
T: +91-80-2783 9925
F: +91-80-2783 9926
sales.bgl@leybold.com
service.bgl@leybold.com

Japan

Leybold Japan Co., Ltd.
Headquarter
Shin-Yokohama A.K.Bldg., 4th Floor
3-23-3, Shin-Yokohama
Kohoku-ku, Yokohama-shi
Kanagawa 222-0033
Japan
Sales:
T: +81-45-471-3330
F: +81-45-471-3323
sales.yh@leybold.com

Leybold Japan Co., Ltd.

Tsukuba Technical Service Center
1959, Kami-yokoba
Tsukuba-shi, Ibaraki-shi 305-0854
Japan
Service:
T: +81-29 839 5480
F: +81-29 839 5485
service.iik@leybold.com

Malaysia

Leybold Malaysia
Leybold Singapore Pte Ltd.
No. 1 Jalan Hi-Tech 2/6
Kulim Hi-Tech Park
Kulim, Kedah Darul
Aman 09000
Malaysia
Sales and Service:
T: +604 4020 222
F: +604 4020 221
sales.ku@leybold.com
service.ku@leybold.com

South Korea

Leybold Korea Ltd.
3F. Jellzone 2 Tower
Jeongja-dong 159-4
Bundang-gu Sungnam-si
Gyeonggi-do
Bundang 463-384, Korea
Sales:
T: +82-31 785 1367
F: +82-31 785 1359
sales.bd@leybold.com
Service:
623-7, Upsung-Dong
Cheonan-Si
Chungcheongnam-Do
Korea 330-290
T: +82-41 589 3035
F: +82-41 588 0166
service.cn@leybold.com

Singapore

Leybold Singapore Pte Ltd.
8 Commonwealth Lane #01-01
Singapore 149555
Singapore
Sales and Service:
T: +65-6303 7030
F: +65-6773 0039
sales.sg@leybold.com
service.sg@leybold.com

Taiwan

Leybold Taiwan Ltd.
No 416-1, Sec. 3
Chunghsin Rd., Chutung
Hsinchu County 310
Taiwan, R.O.C.
Sales and Service:
T: +886-3-500 1688
F: +886-3-583 3999
sales.hc@leybold.com
service.hc@leybold.com

