

Contents

	Page
IMPORTANT SAFETY CONSIDERATIONS . . .	4
1 Description	6
1.1 Function	6
1.2 Supplied equipment	8
1.3 Accessories	9
1.4 Spare parts	9
1.5 Transportation	9
1.6 Technical data	10
1.6.1 Motor related data	11
2 Operation	12
2.1 Installation	12
2.2 Connection to the system	12
2.3 Electrical connection	13
2.3.1 Pump with single-phase AC motor	13
2.3.2 Pump with three-phase AC motor	13
2.4 Start-up	14
2.4.1 Areas of application	14
2.5 Operation	15
2.5.1 Pumping of non-condensable gases	15
2.5.2 Pumping of condensable gases and vapours	15
2.5.3 Operating temperature	15
2.6 Switching off/shutdown	16
2.6.1 Shutdown through monitoring components	16
2.6.2 Failure of the control system or the mains power	16
3 Maintenance	17
3.1 Checking the oil level	17
3.1.1 Checking the condition of N 62 or HE-200 Oil	17
3.2 Oil change	18
3.3 Cleaning the dirt trap	18
3.4 Removing and fitting the internal demister	19
3.5 Disassembly and reassembly of the electric motor	20
3.6 Replacing the outer shaft seal	21
3.7 Removing and remounting the pump module	22
3.7.1 Removing the pump module	22
3.7.2 Remounting the pump module	22
3.8 Leybold service	23
3.8.1 Waste disposal of used pump materials	23
3.9 Storing the pump	23
3.10 Troubleshooting	24
3.11 Maintenance plan	25
EEC Declaration of Conformity	26
EEC Manufacturer's Declaration	27



FOR SALES AND SERVICE PLEASE CALL:

PTB SALES T :: 626.334.0500
 service@ptbsales.com
 www.ptbsales.com

DATE SERVICED: _____

VIEW OUR INVENTORY

We reserve the right to modify the design and the specified data. The illustrations are not binding.



We strongly recommend that you read these Operating Instructions with care so as to ensure optimum operation of the pump right from the start.

Warning

Indicates procedures that must be strictly observed to prevent hazards to persons.



Caution

Indicates procedures that must strictly be observed to prevent damage to, or destruction of the pump.

Figures

The references to diagrams, e.g. (1/2) consist of the Fig. No. and the Item No. in that order.

Leybold-Service

If a pump is returned to LEYBOLD, indicate whether the pump is free of substances damaging to health or whether it is contaminated.

If it is contaminated also indicate the nature of the hazard. LEYBOLD must return any pumps without a „Declaration of Contamination“ to the sender's address.

Disposal of Waste Oil

Owners of waste oil are entirely self-responsible for proper disposal of this waste.

Waste oil from vacuum pumps must not be mixed with other substances or materials.

Waste oil from vacuum pumps (Leybold oils which are based on mineral oils) which are subject to normal wear and which are contaminated due to the influence of oxygen in the air, high temperatures or mechanical wear must be disposed of through the locally available waste oil disposal system.

Waste oil from vacuum pumps which is contaminated with other substances must be marked and stored in such a way that the type of contamination is apparent. This waste must be disposed of as special waste.

European, national and regional regulations concerning waste disposal need to be observed. Waste must only be transported and disposed of by an approved waste disposal vendor.

IMPORTANT SAFETY CONSIDERATIONS

The Leybold TRIVAC B vacuum pump is designed for safe and efficient operation when used properly and in accordance with this manual. It is the responsibility of the user to carefully read and strictly observe all safety precautions described in this section and throughout the manual. This product must be operated and maintained by trained personnel only. Consult local, state, and national agencies regarding specific requirements and regulations. Address any further safety, operation and/or maintenance questions to your nearest Leybold Vacuum office.

Warning Failure to observe the following precautions could result in serious personal injury:



- Before beginning with any maintenance or service work on the TRIVAC B, disconnect the pump from all power supplies.



- Do not operate the pump with any of the covers removed. Serious injury may result.
- If exhaust gases must be collected or contained, do not allow the exhaust line to become pressurised.
- Make sure that the gas flow from the exhaust port is not blocked or restricted in any way.



- The standard version of the TRIVAC B is not suited for operation in explosion hazard areas. Contact us before planning to use the pump under such circumstances.

- Before starting up for the first time, the motor circuit (3 phase) must be equipped with a suitable protective motor switch. Please take note of the information in these Operating Instructions or on the electric motor (wiring diagram).

- The TRIVAC B is not suited for pumping of:
 - combustible and explosive gases or vapours
 - radioactive and toxic substances
 - pyrophorous substances.

- Avoid exposing any part of the human body to the vacuum.

- Never operate the TRIVAC B without a connected intake line or blank flange.

- The location at which the TRIVAC B (including its accessories) is operated should be such that angles over 10° from the vertical are avoided.

- The location of the TRIVAC B should be such that all controls are easily accessible.



- Under certain ambient conditions the TRIVAC B may attain a temperature of over 80 °C (176 °F). There then exists the danger of receiving burns. Note the symbols on the pump pointing to the hazards, and in the case of a hot pump wear the required protective clothing.



- Before pumping oxygen (or other highly reactive gases) at concentrations exceeding the concentration in the atmosphere (> 21 % for oxygen) it will be necessary to use a special pump. Such a pump will have to be modified and de-greased, and an inert special lubricant (like PFPE) must be used.

- Before operating the TRIVAC B with atmospheric gas ballast (optional) check first compatibility with the pumped media so as to avoid hazardous conditions during operation right from the start.

- Before commissioning the TRIVAC B, make sure that the media which are to be pumped are compatible with each other so as to avoid hazardous situations. All relevant safety standards and regulations must be observed.

- It is recommended to always operate the TRIVAC B with a suitable exhaust line which is properly connected. It must slope down and away from the pump.

- When moving the TRIVAC B always use the allowed means. A lifting eye is provided as standard on the pump.

Caution Failure to observe the following precautions could result in damage to the pump:

- Do **not** allow the ingestion of small objects (screws, nuts, washers, pieces of wire, etc.) through the inlet port. Always use the screen which is supplied with every pump.
- Do **not** use the pump for applications that produce abrasive or adhesive powders or condensable vapours that can leave adhesive or high viscosity deposits. Please contact Leybold Sales or Service to select a suitable separator. Also please contact Leybold Sales or Service when planning to pump vapours other than water vapour.
- This pump is suited for pumping water vapour within the specified water vapour tolerance limits.
- Avoid vapours that can condense into liquids upon compression inside the pump, if these substances exceed the vapour tolerance of the pump (> 25 mbar for water vapour).
- Before pumping vapours, the TRIVAC B should have attained its operating temperature, and the gas ballast should be set to position I (position 0 = closed, position I = max. water vapour tolerance, 25 mbar).
The pump will have attained its operating temperature about 30 minutes after starting the pump. During this time the pump should be separated from the process, by a valve in the intake line, for example.
- In the case of wet processes we recommend the installation of liquid separators upstream and downstream of the pump as well as the use of the gas ballast.
- The exhaust line should be laid so that it slopes down and away from the pump so as to prevent condensate from backstreaming into the pump. For this preferably use the flange on the side of the motor.
- The entry of particles and fluids must be avoided under all circumstances.
- Reactive or aggressive substances in the pump chamber may impair the operating oil or modify it. In addition, such substances may be incompatible with the materials of the pump (Viton, grey cast iron, aluminium, steel, resins, glass etc.).
- Corrosion, deposits and cracking of oil within the pump are not allowed.

Note This information will help the operator to obtain the best performance from the equipment:

- Normal amounts of humidity within the range of the pump's vapour tolerance will not significantly affect pump performance when the gas ballast is active. Preferably use the exhaust flange located on the side of the motor.

Caution:

In the case of custom pumps (with a Cat. No. deviating from the Cat No. stated in the EC Declaration of Conformity) please note the information provided on a separate sheet.

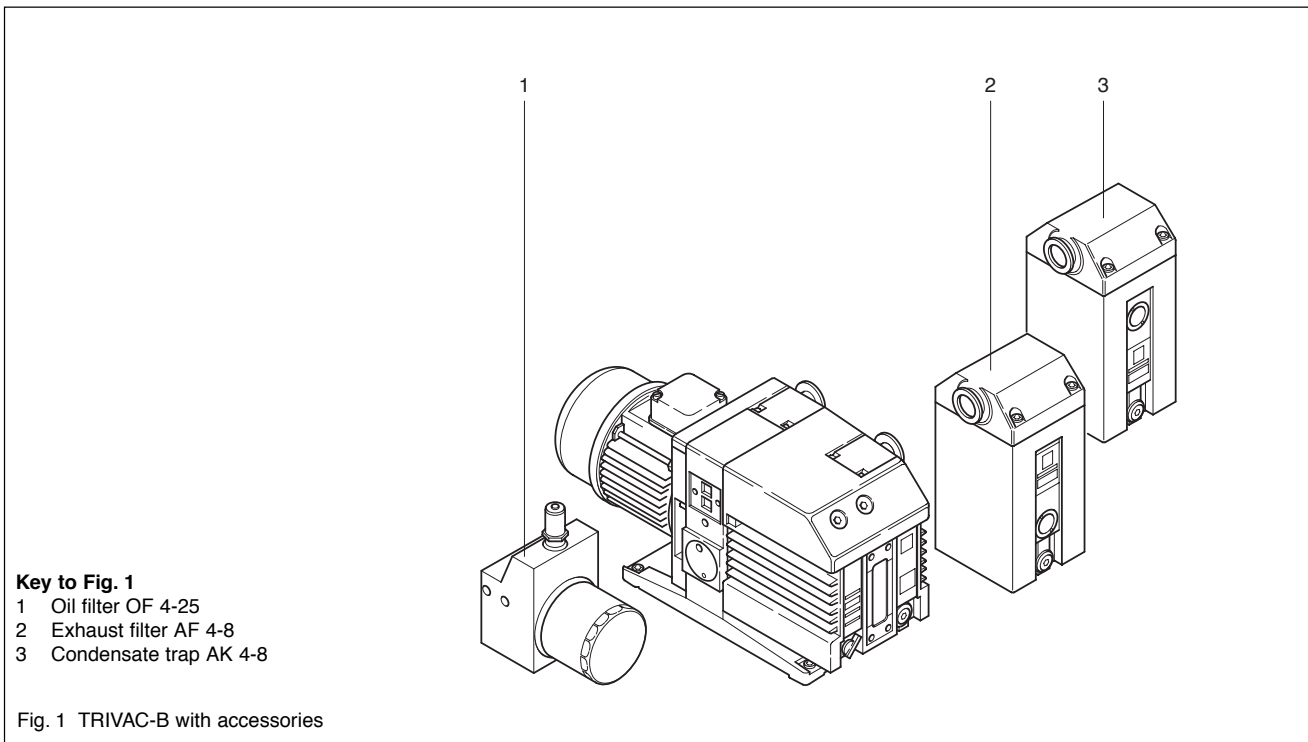

1 Description

TRIVAC-B pumps are oil-sealed rotary vane pumps. The TRIVAC D 4 B and D 8 B are dual-stage pumps. The number in the type designation (4 or 8) indicates the pumping speed in $\text{m}^3 \cdot \text{h}^{-1}$.

TRIVAC-B pumps can pump gases and vapours and evacuate vessels or vacuum systems in the fine vacuum range. Those of standard design are not suitable for pumping greater than atmospheric concentrations of oxygen, hazardous gases, or extremely aggressive or corrosive media.

The drive motor of the TRIVAC-B is directly flanged to the pump at the coupling housing. The pump and motor shafts are directly connected by a flexible coupling. The bearing points of the pump module are force lubricated sliding bearings. All controls as well as the oil-level glass and the nameplate are arranged on the front. All connections are to be found at the sides of the pump. The oil-level glass is provided with prisms for better observation of the oil level.

The pump module consists of assembly parts which are pin-fitted so as to allow easy disassembly and reassembly. The pump module can be easily removed without special tools.

1.1 Function

The rotor (2/7), mounted eccentrically in the pump housing (2/6) (pump chamber), has two radially sliding vanes (2/5) which divide the pump chamber into several compartments. The volume of each compartment changes periodically with the rotation of the rotor.

As a result, gas is sucked in at the intake port (2/1). The gas passes through the dirt trap sieve (2/2), flows past the open anti-suckback valve (2/3) and then enters the pump chamber. In the pump chamber, the gas is passed on and compressed, after the inlet aperture is closed by the vane.

The oil injected into the pump chamber is used for sealing and lubricating. The slap noise of the oil in the pump which usually occurs when attaining the ultimate pressure is prevented by admitting a very small amount of air into the pump chamber.

The compressed gas in the pump chamber is ejected through the exhaust valve (2/10). The oil entrained in the gas is coarsely trapped in the internal demister (2/11); there the oil is also freed of mechanical impurities. The gas leaves the TRIVAC-B through the exhaust port.

During compression, a controlled amount of air – the so-called gas ballast – can be allowed to enter the pump chamber by opening the gas ballast valve (position I).

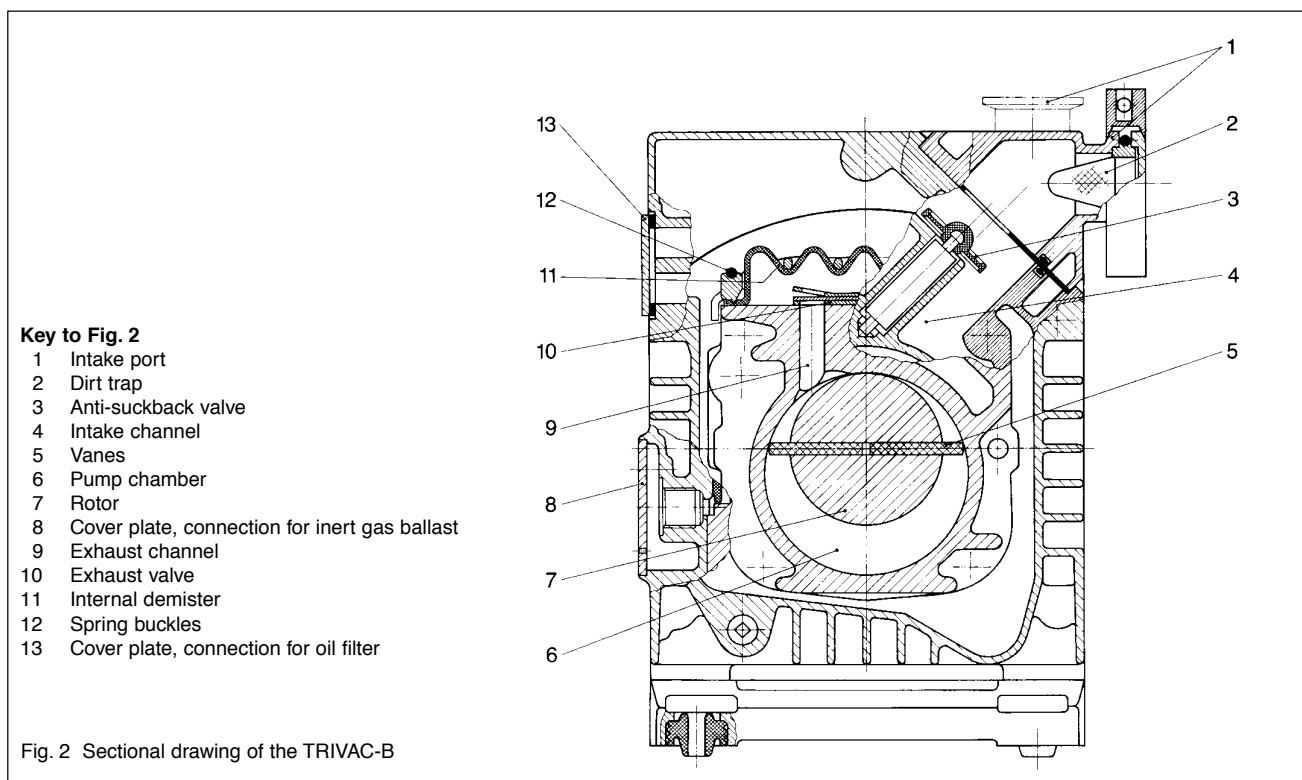

The gas ballast stops condensation of vapours in the pump chamber up to the limit of vapour tolerance as specified in the technical data for the pump (the data refer to water vapour).

The gas ballast valve is opened (position I) and closed (position 0) by turning the gas ballast knob (7/5) on the front.

To enable the TRIVAC-B to be used at intake pressures as high as 1,000 mbar, a special lubricating system was developed featuring force-lubrication of the sliding bearings.

An oil pump (3/6) pumps the oil from the oil reservoir (3/5) into a pressure-lubrication system which supplies oil to all bearing points (3/2). From there the oil enters the pump chamber area (3/4) of the vacuum pump.

The oil pump is fitted in the front end plate on the coupling side of the pump module. The oil suction line is placed low, resulting in a large usable oil reservoir.

The oil is separated from the gas in the TRIVAC-B in two steps as described above. First, small droplets are coalesced into large drops in the internal demister (2/11) fitted above the exhaust valve (2/10). Then, the large drops fall into the oil reservoir as the exhaust gas is diverted by the inner walls of the oil case. Thus a low loss of oil is obtained. This and the large usable oil reservoir ensure long intervals between oil changes even at high intake pressures.

The vacuum is maintained by the TRIVAC-B through an integrated hydropneumatic anti-suckback valve (2/3) which is controlled via the oil pressure.

During operation of the TRIVAC-B the control piston (4/3) remains sealed against a spring (4/2) by the oil pressure. The valve disc (4/6) of the anti-suckback valve is held at the lower position by its own weight (valve open). When the pump stops (because it has been switched off or because of a failure), the oil pressure drops and the spring (4/2) presses the control piston (4/3) up. Thus a connection is provided between the oil case or the oil reservoir (4/1) and the piston (4/4) of the anti-suckback valve. Due to the pressure difference between the oil case and the intake port the oil presses the piston (4/4) up and the valve plate (4/6) against the valve seat (4/5). The quantity of oil in the oil reservoir (4/1) prevents the entry of air into the intake port (2/1) at the beginning of this process.

After the oil has flowed out from the reservoir and when the valve plate rests on the valve seat, air follows in, which vents the pump chamber and forces the valve disc (4/6) against its seat. This effectively prevents backstreaming of oil. The anti-suckback valve (2/3) operates independently of the operating mode of the pump, i.e. also with gas ballast.

Key to Fig. 3

- 1 Accessories
- 2 Bearings
- 3 Non-return valve
- 4 Pump chamber of the TRIVAC
- 5 Oil reservoir
- 6 Oil pump

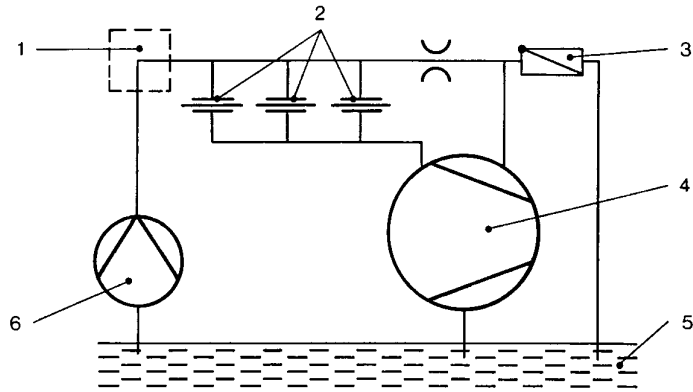
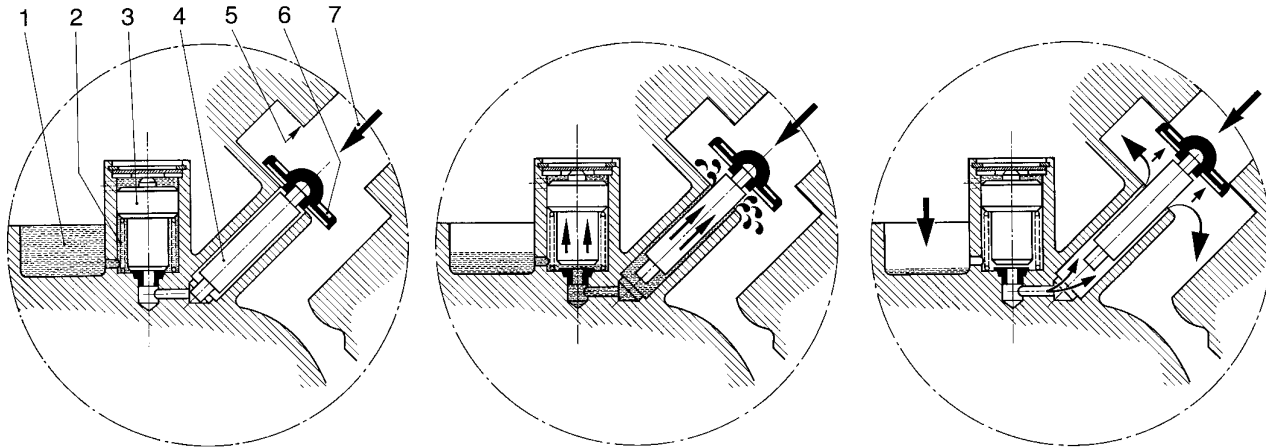

Fig. 3 Schematic of the lubricating system



Key to Fig. 4

- 1 Oil reservoir
- 2 Spring
- 3 Control piston
- 4 Anti-suckback piston
- 5 Valve seat
- 6 Valve disk
- 7 Gas inlet

Fig. 4 Hydropneumatic anti-suckback valve

1.2 Supplied Equipment

The equipment supplied with the TRIVAC-B pump includes:

Pump with motor, including initial filling of N 62, HE-200 oil or Arctic oil SHC 224 (for Cat. No. 113 08 and 113 18).

- 1 centering ring,
- 1 centering ring with dirt trap,
- 2 clamping rings DN 16 KF.

As protection during shipment, the connection ports are each blanked off by rubber diaphragms and supporting rings.

TRIVAC-B pumps with single-phase AC motor are supplied ready to operate with switch, built-in thermal motor protection switch, mains cable (2 m) and mains plug.

For TRIVAC-B pumps with three-phase AC motor, the switch, motor protection switch, mains cable etc. are not included but can be delivered upon request with motor protection switch, mains plug and mains cable.

1.3 Accessories

	Cat. No. / Ref. No.
Condensate trap AK 4-8, DN 16 KF	188 06
Exhaust filter AF 4-8, DN 16 KF	189 06
Drain tap for condensate trap, exhaust filter, oil drain of the pump, vacuum-tight	190 90
oil tight	190 90
Exhaust filter with lubricant return AR 4-8, DN 16 KF	189 20
Dust filter FS 2-4	186 05
Fine vacuum adsorption trap FA 2-4 (with zeolite)	187 05
Adsorption trap (with aluminium oxide)	854 14
(with cryo insert)	854 17
Cold trap TK 4-8	188 20
Oil filter OF 4-25	101 91
Chemical filter CF 4-25	101 96
Adapter for gas ballast port M 16 x 1.5 – DN 16 KF	168 40
M 16 x 1.5 – 3/8 inch NPT	99 175 011

Oil N 62	1l	177 01
	5l	177 02
	20 l	177 03
Arctic oil SHC 224	1l	200 28 181

(Order from LH Cologne, Germany)

Oil HE-200	1 qt	98 198 006
	12 qt case	98 198 049
	1 gal	98 198 007
	5 gal	98 198 008

(Order from LHVP, Export Pa., USA)

The oil grades N 62 and HE-200 are interchangeable.
Special oils upon request.

Caution Only use the kind of oil specified by Leybold. Alternative types of oil are specified upon request.

1.4 Spare Parts

Set of gaskets		197 20
Pump module, complete	D 4 B	200 10 989
	D 8 B	200 10 991
Module-gasket		200 10 730*)
Oil case gasket		200 10 733*)
Internal demister	D 4 B	390 26 010*)
	D 8 B	390 26 011*)

*) included in gasket set

1.5 Transportation

Caution • Pumps which are filled with operating agents must only be moved while standing upright. Otherwise oil may escape. Avoid any other orientations during transport.

Warning • Check the pump for the presence of any oil leaks, since there exists the danger that someone may slip on spilt oil.
• When lifting the pump you must make use of the crane eyes provided on the pump for this purpose; also use the recommended type of lifting device.



1.6 Technical Data

		TRIVAC D 4 B		TRIVAC D 8 B	
		50 Hz	60 Hz	50 Hz	60 Hz
Nominal pumping speed ¹⁾	m ³ x h ⁻¹ (cfm)	4.8 (2.8)	5.8 (3.4)	9.7 (5.7)	11.6 (6.9)
Pumping speed ¹⁾	m ³ x h ⁻¹ (cfm)	4.2 (2.5)	5 (3)	8.5 (5)	10.2 (6)
Ultimate partial pressure without gas ballast ¹⁾	mbar (Torr)	10 ⁻⁴ (0.75 x 10 ⁻⁴)			
Ultimate total pressure without gas ballast ¹⁾	mbar (Torr)	< 2 x 10 ⁻³ (< 1.5 x 10 ⁻³)			
Ultimate total pressure with gas ballast ¹⁾	mbar (Torr)	< 5 x 10 ⁻³ (< 3.8 x 10 ⁻³)			
Water vapor tolerance ¹⁾	mbar (Torr)	30 (22.5)		25 (18.8)	
Water vapor capacity	gm/h	93		157	
Oil filling, min./max.	l (qt)	0.3 / 0.8 (.3 / .85)		0.3 / 0.9 (.3 / .95)	
Noise level * to DIN 45 635, without/with gas ballast	dB(A)	50 / 52			
Admissible ambient temperature	°C (°F)	12 - 40 (54 - 104)			
Motor rating *	W (HP)	370 (.50)			
Nominal speed	rpm	1500	1800	1500	1800
Type of protection	IP	54			
Weight*	kg (lbs)	18.7 (41.2)		21.2 (46.7)	
Connections, Intake and Exhaust	DN	16 KF			

¹⁾ To DIN 28 400 and following numbers

* Weight, motor rating and noise levels for the pumps with 230 V, 50 Hz AC motor only.

Caution We can only guarantee that the pump will meet its specifications when using the type of lubricant which has been specified by us.

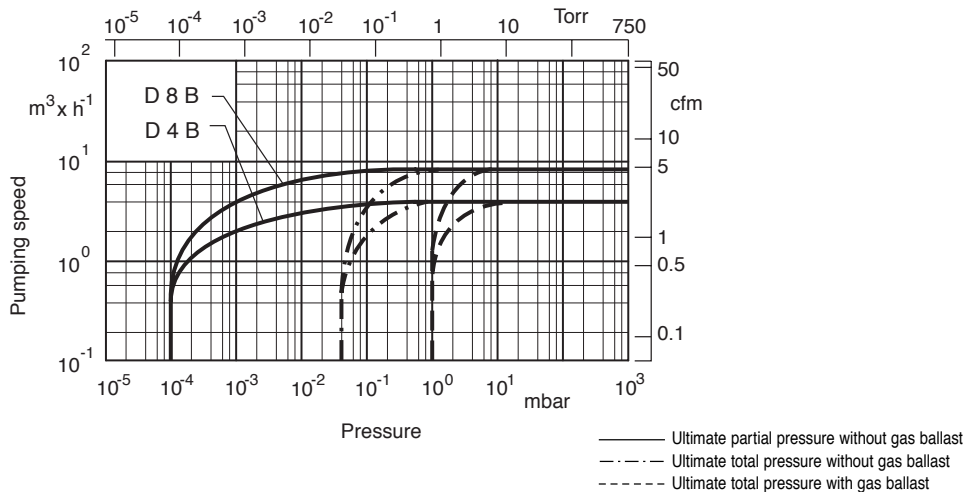

Fig. 5 Pumping speed characteristics at 50 Hz (60 Hz curves at the end of the section)

1.6.1 Motor related data

D 4 B			D 8 B			Motor connection voltage, frequency	Motor power	Rated current	Speed	Motor noise level	Order No. motor
Cat. No.	l (mm)	W (kg)	Cat. No.	l (mm)	W (kg)						
112 45	430	18,7	112 55	455	21.2	1~, 230 V, 50 Hz	370 W	2,9 A	1400	47 dB(A)	360 66 008
113 03	430	18,7	113 13	455	21,2	1~, 115 V, 60 Hz	370 W	5,6 A	1700	51 dB(A)	200 10 403
113 04	470	19,7	113 14	495	25,2	1~, 100 V, 50 Hz	370 W	8,7 A	1400	53 dB(A)	200 10 404
113 08 ¹⁾	470	19,7	113 18 ¹⁾	495	25,2	1~, 110 V, 60 Hz	370 W	6,1 A	1700	56 dB(A)	200 10 404
112 46	438	16,4	112 56	463	18,6	3~, 230/400 V, 50 Hz 250/440 V, 60 Hz	370 W	1,95/1,12 A 1,73/1,0 A	1970 1680	46 dB(A) 50 dB(A)	380 66 006
113 06	430	18	113 16	455	18,6	3~, 230/400 V, 50 Hz	370 W	1,92/1,11 A	1395	45 dB(A)	200 10 406
113 07	223	10,6	113 17	248	12,8	ohne Motor	-	-	-	48 dB(A)	-
113 09			113 21			1~, 230 V, 50/60 Hz	370 W	4,9/3,3 A	1400 1700	53/56 dB(A)	200 39 867

¹⁾ Motor with UL cable NEMA 5-158 and 2.5 m long cable

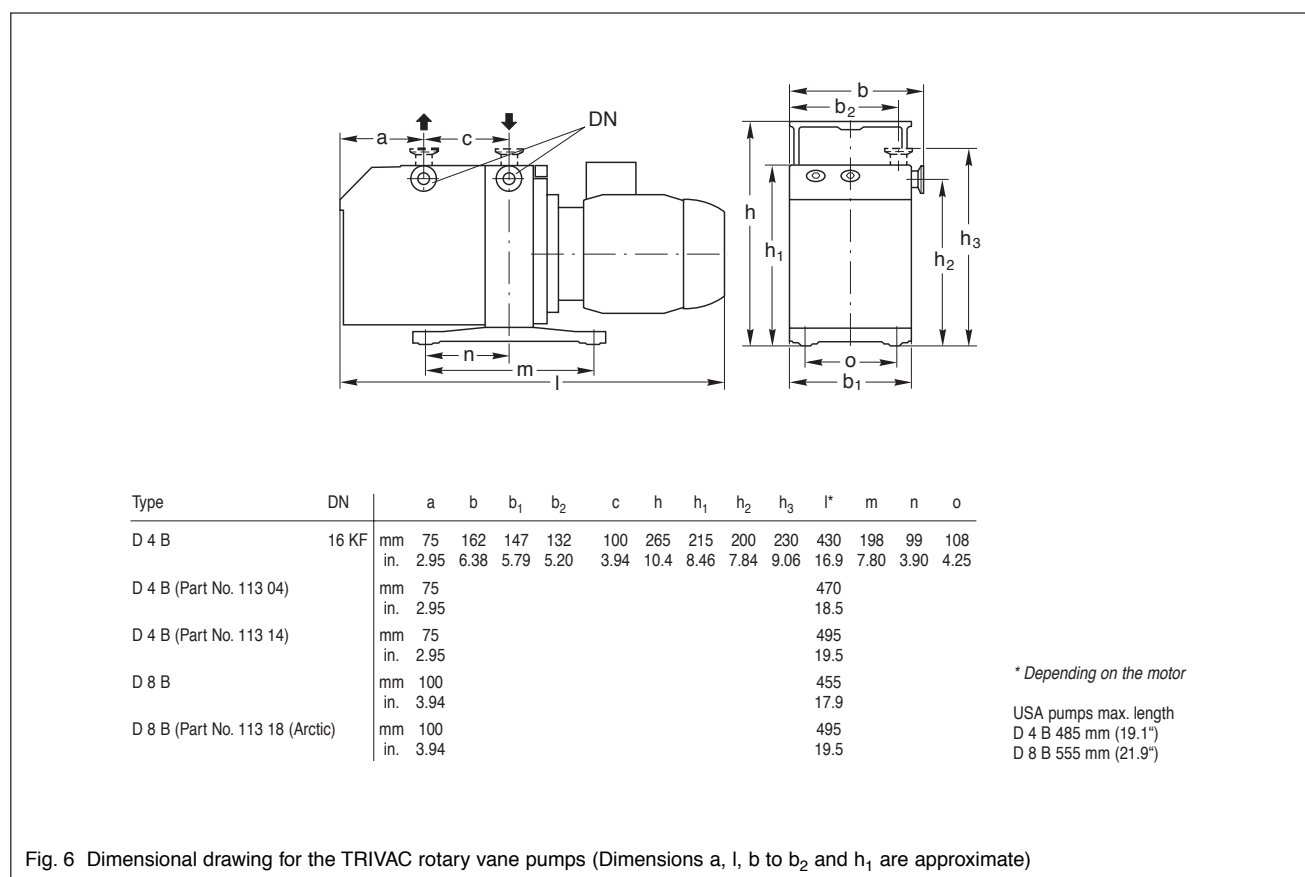

Fig. 6 Dimensional drawing for the TRIVAC rotary vane pumps (Dimensions a, l, b to b₂ and h₁ are approximate)

Key to Fig. 7

- 1 Handle
- 2 Intake port
- 3 Exhaust port
- 4 Oil-level glass
- 5 Gas ballast knob
- 6 Threaded connection M 16 x 1.5 for inert gas ballast
- 7 Adapter
- 8 Cover plate
- 9 Cover plate; connection for oil filter

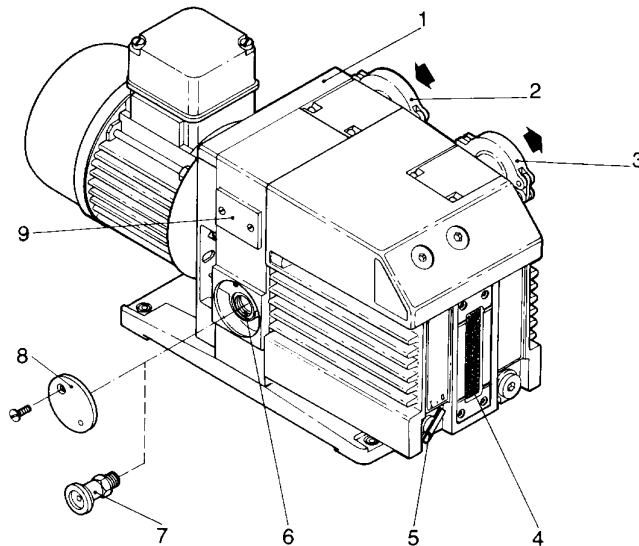

Fig. 7 Connections and controls

2 Operation

2.1 Installation

Warning The standard pump (except the versions equipped with an explosion hazard rated motor) is not suited for installation in explosion hazard areas. When planning such an application please contact us first.



The TRIVAC-B pump can be set up on a flat, horizontal surface. Rubber feet under the coupling housing ensure that the pump can not slip.

If you wish firmly install the pump in place, insert bolts through bore holes in the rubber feet.

Caution Max. tilt for the pump (without further attachment) with possibly fitted standard accessories is 10° from the vertical.

The rubber feet act as vibration absorbers. They must therefore not be compressed by screws. When installing the TRIVAC-B pump, make sure that the connections and controls are readily accessible.

The site chosen should allow adequate air circulation to cool the pump (keep front and rear unobstructed). The ambient temperature should not exceed +40 °C (104 °F) and not drop below +12 °C (55 °F) (see Section 2.5.3).

The max. amount of heat given off approximately corresponds to the rated motor power.

2.2 Connection to the System

Before connecting the TRIVAC-B, remove the shipping seals from the connection flanges (7/2) and (7/3).

Caution Retain the shipping seals in case you need to store the pump in the future.

The pump is shipped with intake and exhaust flanges mounted for horizontal connection of the connecting lines. You can easily convert the ports for vertical connection by removing the four capscrews, rotating the flanges as required, and reinstalling the capscrews.

Connect the intake and exhaust lines with a centering ring and a clamping ring each. Use the centering ring with dirt trap for the intake port.

Connect the intake and exhaust line using anti-vibration bellows, without placing any strain on the pump.

The intake line must be clean. Deposits in the intake line may outgas and adversely affect the vacuum. The connecting flanges must be clean and undamaged.

The maximum throughput of the pump is equivalent to the pumping speed of the pump (see Section 1.6).

Caution The cross-section of the intake and exhaust lines should be at least the same size as the connection ports of the pump. If the intake line is too narrow, it reduces the pumping speed. If the exhaust line is too narrow, overpressures may occur in the pump; this might damage the shaft seals and cause oil leaks. The maximum pressure in the oil case must not exceed 1.5 bar (absolute).

When pumping vapours, it is advisable to install condensate traps on the intake and exhaust sides.

Install the exhaust line with a downward slope (lower than the pump) so as to prevent condensate from flowing back into the pump. If this is not possible, insert a condensate trap.

The exhaust gases from the vacuum pump must be safely lead away and subjected to post-treatment as required. In order to reduce the emission of oil vapours we recommend the installation of an additional exhaust filter (Leybold accessory).

Depending on the type of application or the kind of pumped media, the corresponding regulations and information sheets must be observed.

The pumps may be operated with an inert gas ballast via a connection which is provided for this purpose. The cover plate (7/8) can be removed to gain access to this M 16 x 1.5 threaded port (7/6). Matching connectors are available (see Section 1.3).

In inlet pressure for the gas ballast should be about 1000 mbar (absolute) and sufficient quantities of gas must be available (about $\frac{1}{10}$ of the pumping speed).

Warning Never operate the pump with a sealed exhaust line. There is the danger of injury.



Before starting any work on the pump, the personnel must be informed about possible dangers first. All safety regulations must be observed.

2.3 Electrical Connections

Warning Before wiring the motor or altering the wiring, ensure that mains supply for the pump is off and that it can not be applied inadvertently.



In order to prevent the pump from running up unexpectedly after a mains power failure, the pump must be integrated in the control system in such a way that the pump can only be switched on again manually. This applies equally to emergency cut-out arrangements.

Electrical connections must be done by a qualified electrician as defined by VDE 0105 in accordance with the VDE 0100 guidelines.

Observe all safety regulations.

TRIVAC-B pumps are available with a single-phase or a three-phase AC motor.

2.3.1 Pump with Single-Phase AC Motor

Pumps equipped with a single-phase AC motor may be connected directly to the mains via the mains cord and the mains plug.

At 230 V use at least a 6 A slow-blow or a 10 A fast-blow fuse.

The direction of rotation need not be checked as it is fixed.

The motor is protected against overloading by a thermal overload switch with automatic resetting.

Warning If the thermal overload protector shuts off the pump, the motor will restart itself as soon as it cools. That's why the mains plug should be disconnected from the mains before starting with any work on the pump.



2.3.2 Pump with Three-Phase AC Motor

TRIVAC-B pumps with a three-phase motor are supplied without accessories for the electrical connection. They must be connected via the appropriate cable, and a suitable motor protection switch. Set the switch in accordance with the rating on the motor nameplate.

Fig. 8 shows the connection for pumps with 230/400 V, 50 Hz motors. Please also observe the motor wiring diagram in the junction box and the information given on the nameplate of the motor.

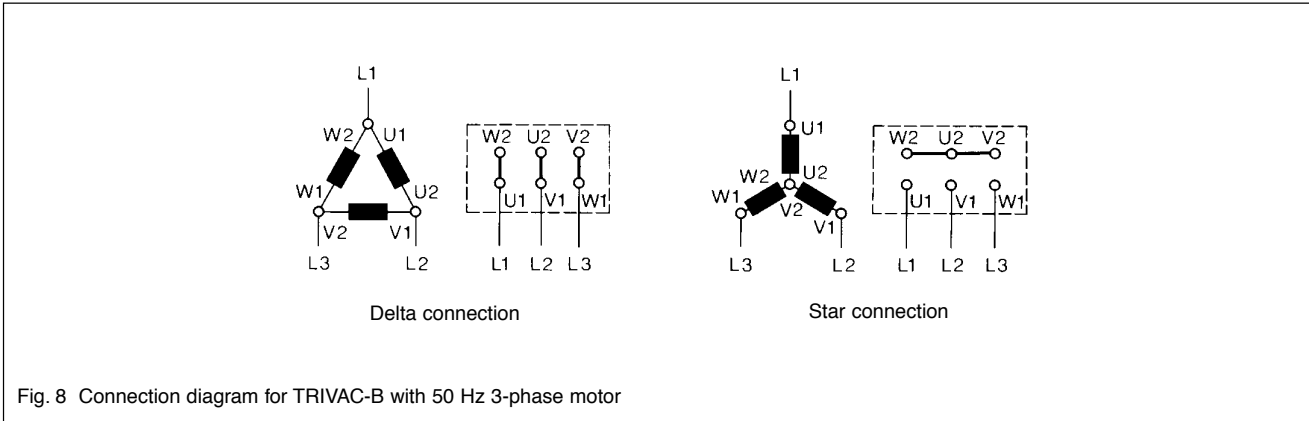

Fig. 8 Connection diagram for TRIVAC-B with 50 Hz 3-phase motor

Caution After connecting the motor and after every time you alter the wiring, check the direction of rotation. To do so, briefly switch on the motor and check whether a suitable cover (e. g. a blank flange) is sucked on at the intake port. If not, interchange two phases of the connection. Observe the direction arrow on the coupling housing.

2.4 Start-up

Each time before starting up ensure that the oil level is visible in the oil level glass.

For pumps with 3-phase motors, check the direction of rotation before starting the pump

for the first time and after each change in the electrical connection (see Section 2.3.2).

On initial start-up, after prolonged idle periods or after an oil change, the specified ultimate pressure cannot be attained immediately until the oil is degassed. This can be done by running the pump for approx. 30 min. with the intake line closed and the gas ballast valve (7/5) open.

Warning Before starting the pump ensure that the pump and the fitted accessories meet the requirements of your application and that safe operation can be guaranteed.



Avoid exposure of any part of the body to the vacuum. There is the danger of injury. Never operate the pump with an open intake port. Vacuum connections as well as oil-fill and oil-drain openings must never be opened during operation.

Warning The safety regulations which apply to the application in each case must be observed. This applies to installation, operation and during maintenance (service) as well as waste disposal and transportation. The standard pump is not suited for pumping of hazardous gases or vapours.



Our technical sales department is available for further advice in these matters.

2.4.1 Areas of Application

Warning Before pumping oxygen (or other highly reactive gases) at concentrations exceeding the concentration in the atmosphere (> 21 % for oxygen) it will be necessary to use a special pump. Such a pump will have to be modified and de-greased, and an inert special lubricant (like PFPE) must be used.



The pump is not suitable for pumping of:

- ignitable and explosive gases or vapours
- oxidants
- pyrophorous gases.

Caution The pumps are not suitable for pumping of liquids or very dusty media. Suitable protective devices must be installed.

Our technical sales department is available for further advice in these matters.

2.5 Operation

TRIVAC-B pumps can pump condensable gases and vapours, provided that the gas ballast valve (7/5) is open and the pump has attained its operating temperature.

2.5.1 Pumping of Non-Condensable Gases

If the process contains mainly permanent gases, the pump may be operated without gas ballast (position 0), provided that the saturation vapour pressure at operating temperature is not exceeded during compression.

If the composition of the gases to be pumped is not known and if condensation in the pump cannot be ruled out, run the pump with the gas ballast valve open in accordance with Section 2.5.2.

2.5.2 Pumping of Condensable Gases and Vapours

With the gas ballast valve open (position I) and at operating temperature, TRIVAC-B pumps can pump pure water vapour up to the water vapour tolerance specified by the technical data. If the vapour pressure increases above the permissible level, the water vapour will condense in the oil of the pump.

When pumping vapours ensure that the gas ballast valve is open and that the pump has been warmed up for approximately 30 minutes with the intake line closed.

Caution Vapour phases may only be pumped up to the permissible limit after the pump has attained its operating temperature.

During pumping, vapours may dissolve in the oil. This changes the oil's properties and thus there is a risk of corrosion in the pump. Therefore, don't switch off the TRIVAC-B immediately after completion of the process. Instead, allow the pump to continue operating with the gas ballast valve open and the intake line closed until the oil is free of condensed vapours. We strongly recommend operating the TRIVAC-B in this mode for about 30 minutes after completion of the process.

In cyclic operation, the TRIVAC-B should not be switched off during the intervals between the individual working phases (power consumption is minimal when the pump is operating at ultimate pressure), but should continue to run with gas ballast valve open and intake port closed (if possible via a valve).

Once all vapours have been pumped off from a process (e.g. during drying), the gas ballast valve can be closed to improve the attainable ultimate pressure.

2.5.3 Operating Temperature

Proper operation of the TRIVAC-B is ensured in the ambient temperature range between 12 °C to 40 °C (55 °F to 104 °F).

At operating temperature, the surface temperature of the TRIVAC-B may lie between 40 °C and over 80 °C (104 °F and 176 °F), depending on the load.

Warning The surface temperature of the TRIVAC-B pumps may rise above 80 °C.



There is the danger of receiving burns.



2.6 Switching Off/Shutdown

Under normal circumstances, all that you need do is to electrically switch off the TRIVAC-B.

No further measures will be required.

When pumping condensable media let the pump continue to operate with the gas ballast valve open and the intake line closed before switching off (see Section 2.5.2).

When pumping aggressive or corrosive media, let the pump continue to operate even during long non-working intervals (e.g. overnight) with the intake line closed and the gas ballast valve open. This avoids corrosion during idle periods.

If the TRIVAC-B is to be shutdown for an extended period after pumping aggressive or corrosive media or if the pump has to be stored, proceed as follows:

Warning When pumping harmful substances, take adequate safety precautions.



Our technical sales department is available for further advice in these matters.

Drain the oil (see Section 3.2).

Add clean oil until the oil-level is at the “min” mark (see Section 3.2) and let the pump operate for some time.

Then drain the oil and add clean oil until the oil level is at the “max.” mark (see Section 3.2).

Seal the connection ports. Special conservation or anti-corrosion oils aren't necessary.

Caution Please also take note of the information given in Section 3.9 (storage and storage conditions).

2.6.1 Shutdown through Monitoring Components

Warning When the pump has been switched off due to overheating sensed by the motor coil protector, the pump must only be started manually after the pump has cooled down to the ambient temperature and after having removed the cause first.



2.6.2 Failure of the Control System or the Mains Power

Warning In order to prevent the pump from running up unexpectedly after a mains power failure, the pump must be integrated in the control system in such a way that the pump can only be switched on again manually. This applies equally to emergency cut-out arrangements.



3 Maintenance

Warning Disconnect the electrical connections before disassembling the pump. Make absolutely sure that the pump cannot be accidentally started.



If the pump has pumped harmful substances, contrary to what has been stated in Section 2.4, ascertain the nature of hazard and take adequate safety measures.



Observe all safety regulations.

If you send a pump to LEYBOLD for repair please indicate any harmful substances existing in or around the pump. A form is available from LEYBOLD for this purpose.

Caution When disposing of used oil, you must observe the applicable environmental regulations!

Due to the design concept, TRIVAC-B pumps require very little maintenance when operated under normal conditions. The work required is described in the sections below. In addition to this, a maintenance plan is provided in Section 3.11.

Caution All work must be carried out by suitably trained personnel. Maintenance or repairs carried out incorrectly will affect the life and performance of the pump and may cause problems when filing warranty claims.

For the spare part numbers please refer to the enclosed spare parts list.

In case of special versions please always state the special number, model number and the serial number.

LEYBOLD offers practical courses on the maintenance, repair, and testing of TRIVAC-B pumps. Further details are available from LEYBOLD on request.

Caution If the TRIVAC-B is used in ambient air which is much contaminated, make sure that the air circulation and the gas ballast valve are not adversely affected.

When the TRIVAC-B has been pumping corrosive media, we recommend to perform any possibly planned maintenance work immediately in order to prevent corrosion of the pump while at standstill.

3.1 Checking the Oil Level

During operation of the TRIVAC-B the oil level must always remain between marks (9/2) and (9/3) on the oil-level glass. The amount of oil must be checked and topped up as required.

Caution Fill in oil only after the pump has been switched off.

3.1.1 Checking the Condition of N 62 or HE 200 Oil

The ageing process for the standard operating fluid N 62 resp. HE 200 (see Chapter 1.2.1) will depend very much on the area of application for the pump.

a) Visual check

Normally the oil is clear and transparent. If the oil darkens, it should be changed.

b) Chemical check

The neutralisation number of N 62 oil is determined according to DIN 51558. If it exceeds 2, the oil should be changed.

c) Viscosity check

If the viscosity of N 62 at 25 °C exceeds a level of 240 mPas (20% higher than the viscosity of fresh oil) an oil change is recommended.

If gases or liquids dissolved in the oil result in a deterioration of the ultimate pressure, the oil can be degassed by allowing the pump to run for approx. 30 min. with the intake port closed and the gas ballast valve open.

When wanting to check the oil, switch off the pump first and drain out from the warm pump the required amount of oil through the oil drain (9/4) into a beaker or similar.

Caution Please note the safety information given in Chapter 3.2.

3.2 Oil Change

Warning Before pumping oxygen (or other highly reactive gases) at concentrations exceeding the concentration in the atmosphere



(> 21 % for oxygen) it will be necessary to use a special pump. Such a pump will have to be modified and de-greased, and an inert special lubricant (like PFPE) must be used.

Hazardous substances may escape from the pump and the oil. Take adequate safety precautions. For example wear gloves, face protection or breathing protection.

Observe all safety regulations.

For proper operation of the pump, it is essential that the pump has an adequate supply of the correct and clean oil at all times.

The oil must be changed when it looks dirty or if it appears chemically or mechanically worn out (see Section 3.1.1).

The oil should be changed after the first 100 operating hours and then at least every 2,000 to 3,000 operating hours or after one year. At high intake pressures and intake temperatures and/or when pumping contaminated gases, the oil will have to be changed more frequently.

Further oil changes should be made before and after long-term storage of the pump.

If the oil becomes contaminated too quickly, install a dust filter and/or oil filter (see Section 1.3). Contact us for more information in this matter.

Caution Only change the oil after the pump has been switched off and while the pump is still warm.

Required tool: Allen key 8 mm.

Remove the oil-drain plug (9/4) and let the used oil drain into a suitable container. When the flow of oil slows down, screw the oil-drain plug back in, briefly switch on the pump (max. 10 s) and then switch it off again. Remove the oil-drain plug once more and drain out the remaining oil.

Screw the oil-drain plug back in (check the gasket and reinstall a new one if necessary).

Remove the oil-fill plug (9/1) and fill in with fresh oil.

Screw the oil-fill plug (9/1) back in.

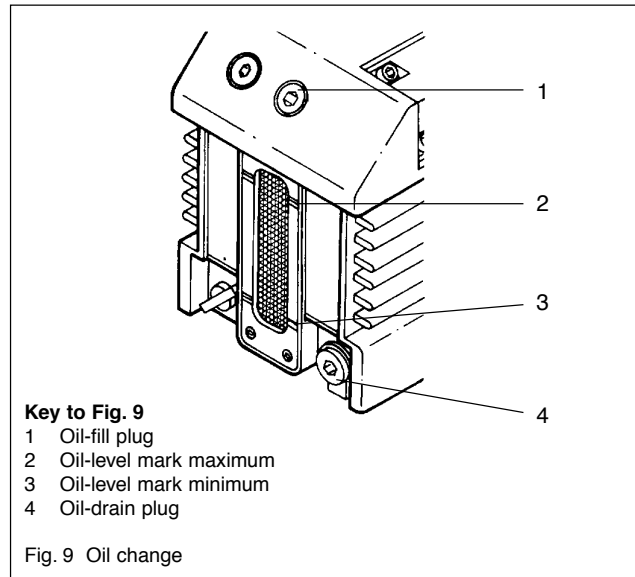

Warning If there is the danger that the operating agent may present a hazard in any way due to decomposition of the oil, or because of the media which have been pumped, you must determine the kind of hazard and ensure that all necessary safety precautions are taken.



Caution We can only guarantee that the pump operates as specified by the technical data if the lubricants recommended by us are used.

3.3 Cleaning the Dirt Trap

A wire-mesh sieve is located in the intake port of the pump to act as a dirt trap for coarse particles. It should be kept clean to avoid a reduction of the pumping speed.

For this purpose, remove the dirt trap (2/2) from the intake port and rinse it in a suitable vessel with solvent. Then thoroughly dry it with compressed air. If the dirt trap is defective, replace it with a new one.

Caution The cleaning intervals depend on the application. If the pump is exposed to large amounts of abrasive materials, a dust filter should be fitted into the intake line.

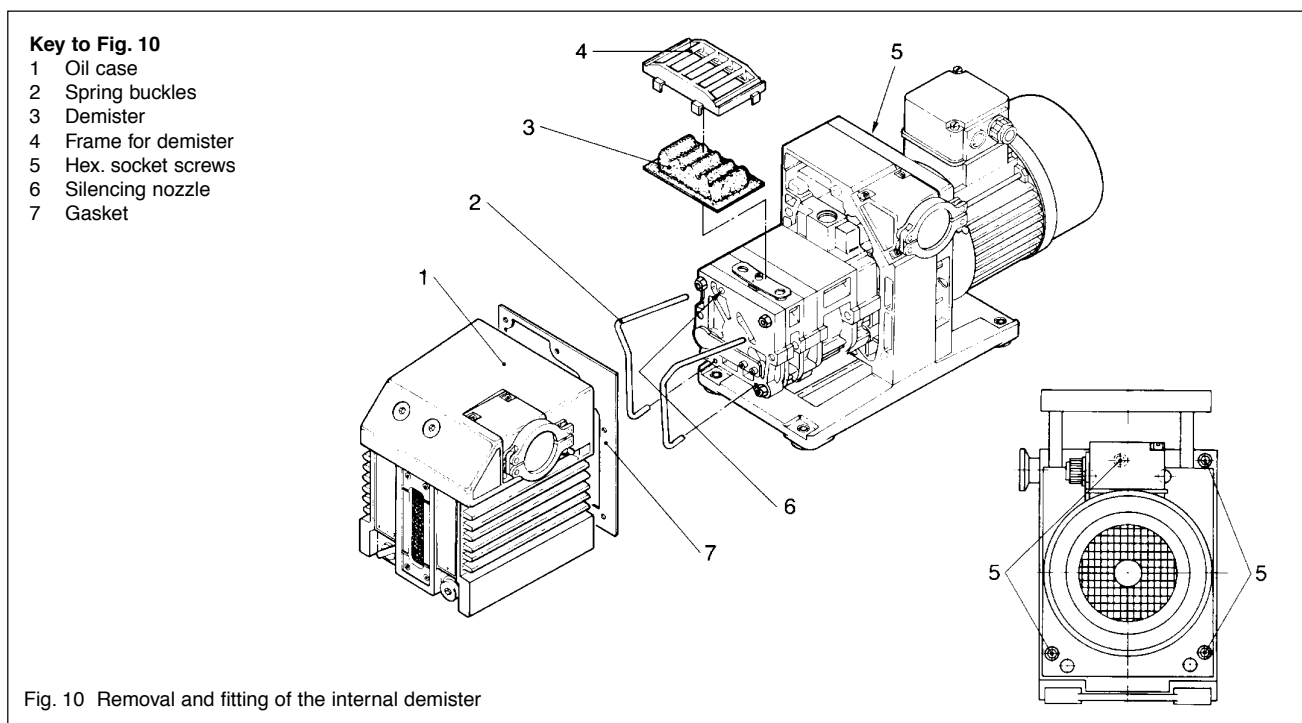

3.4 Removing and Fitting the Internal Demister

Required tools:

Allen keys 5 mm and 8 mm

The internal demister is spring-mounted in a frame. When it is clogged, it rises periodically to reduce the pressure difference created.

The resultant noise at high intake pressures indicates that the internal demister is dirty.

Periodically clean or replace the internal demister; the maintenance interval depends on the application. Use a suitable solvent for cleaning.

Shutdown the pump and drain the oil (see Section 3.2).

Pull the handle upward.

Remove the **four recessed** screws (10/5) on the oil case (10/1). Don't remove the **non-recessed screws**; they hold the motor flange in place.

Pull the oil case forward off the pump.

Remove the gasket (10/7).

Press the spring buckles (10/2) sideways away from the frame (10/4). Lift off the frame (10/4) and remove the internal demister (10/3).

Clean all parts and check that they are in perfect condition; if not, replace them with new parts.

Reassemble in the reverse order.

Caution Torque for the screws (10/5) is 5 Nm.

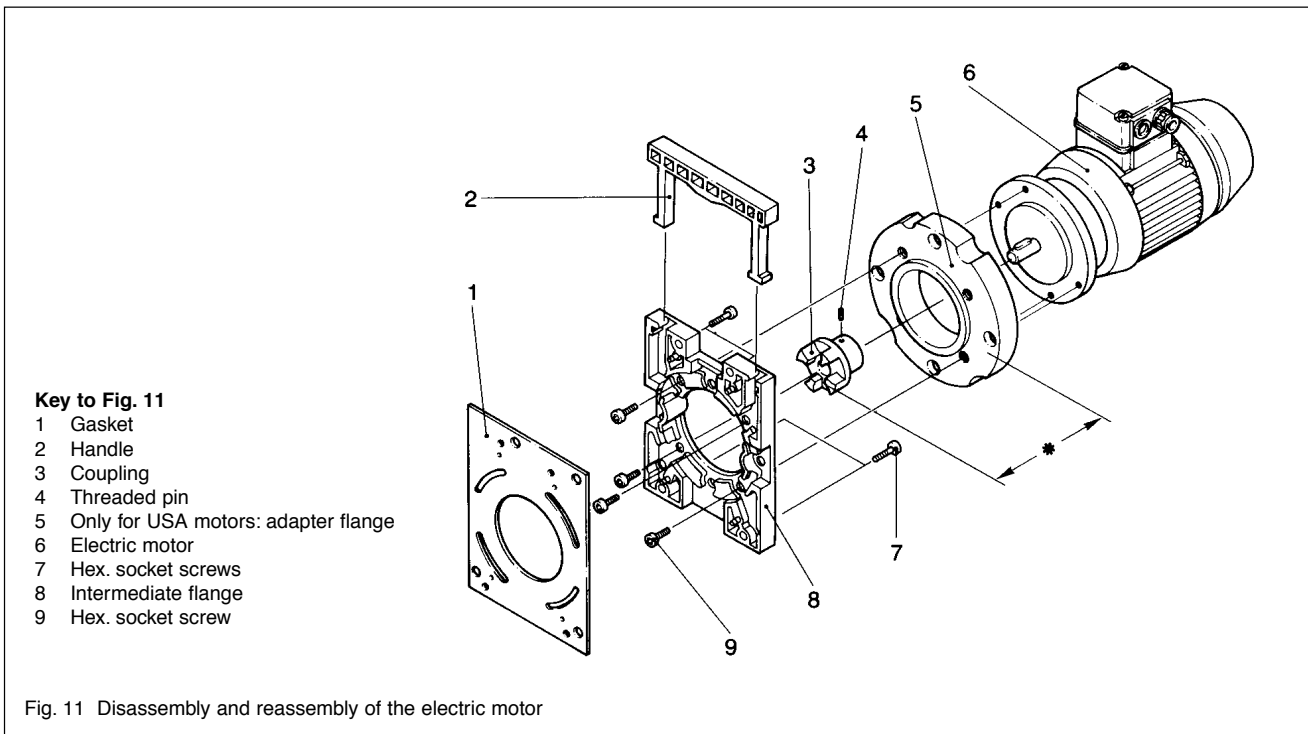

Fig. 11 Disassembly and reassembly of the electric motor

3.5 Disassembly and Reassembly of the Electric Motor

Warning Before starting work, always disconnect the motor from the mains. Disconnect the wires in the junction box of the motor (three-phase models only) or pull the mains plug.



Required tools:

Screwdriver 1.0 x 5.5 mm (for junction box), open-jaw wrenches 7 mm and 19 mm (for junction box), Allan keys 2.5 mm, 3 mm, 5 mm, 6 mm, possibly puller for coupling.

Disconnect the wires in the junction box of the motor (three-phase models only) or pull the mains plug.

Place the pump on its front side.

Unscrew the four non-recessed hex. socket screws (11/7).

Remove the intermediate flange (11/8) together with the electric motor.

Take off the gasket (11/1).

Remove the handle (11/2).

Loosen the threaded pin (11/4) and pull the coupling (11/3) off the motor shaft.

Unscrew the hex. socket screws (11/9).

Remove the electric motor (11/6) (and the adapter flange (11/5) in the case of the USA motors).

Clean all parts and check that they are in perfect condition; if not, replace them with new parts.

Reassemble in the reverse order.

Caution In the case of 60 Hz motors (USA versions) with adapter flange the coupling must not be pushed on to the shaft right up to the stop. On the other hand if it is not pushed on far enough the pump module may be damaged during operation. Push the coupling on in such a way that the distance between the front end of the coupling (11/3) and front side of the adapter flange (11/5) amounts to 41.3 ± 0.8 mm ($1 \frac{5}{8} \pm \frac{1}{32}$ inch) (see Fig. 11). The adapter flange (11/5) is screwed to the motor flange with four additional screws.

Key to Fig. 12

- 1 Coupling element
- 2 Hexagon socket screw
- 3 Spring washer
- 4 Coupling (one half)
- 5 Key
- 6 Compression disc
- 7 O-ring
- 8 Bushing
- 9 Shaft seal
- 10 Centering disk
- 11 Hexagon socket screws

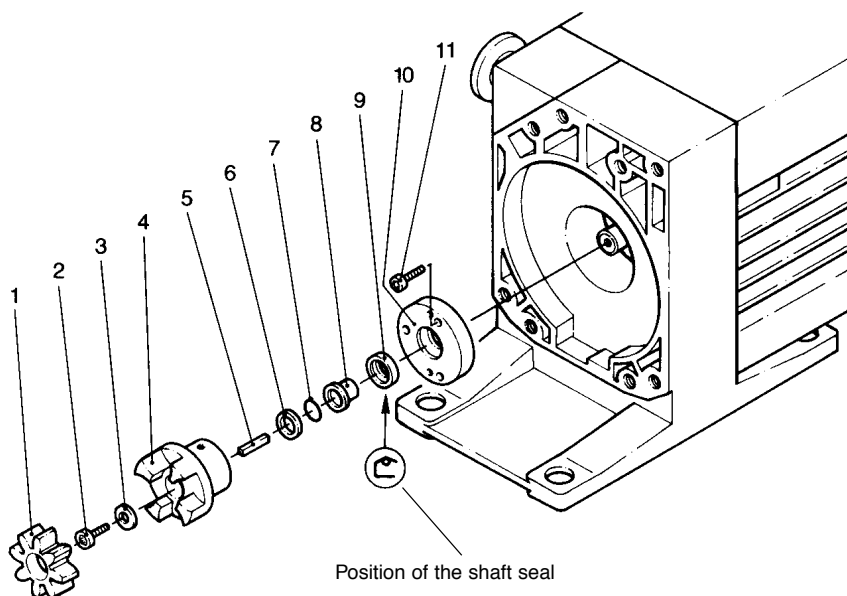

Fig. 12 Exchanging the outer shaft seal

3.6 Replacing the Outer Shaft Seal

Required tools:

Allen keys 3 mm, 5 mm, 8 mm, flat-nose pliers, plastic hammer, shaft seal driver, possibly puller for coupling.

The TRIVAC 4/8 B has two shaft seals; the outer one is subject to greater wear. Oil marks under the coupling housing are signs of a damaged outer shaft seal.

The outer shaft seal can be replaced without removing or disassembling the pump module.

Shutdown the pump.

Drain the oil (see Section 3.2) or place the pump on its front side.

Unscrew the four **non-recessed** hex. socket screws (11/7) and remove the motor (11/6) together with the intermediate flange (11/8).

Remove the gasket (11/1).

Pull off the coupling element(12/1).

Remove the hex. socket screw (12/2) and the spring washer (12/3).

Remove the coupling half (12/4).

Remove the key (12/5).

Pull off the compression disc (12/6) and the O-ring (12/7).

Unscrew the hex. socket screws (12/11) and pull off the centering disk (12/10) together with the bushing (12/8).

If the centering disk is stuck, screw the capscrews (12/11) into the jackscrew holes in the centering disk.

Pull the bushing out from the centering disk and force the shaft seal (12/9) out of the centering disk.

Caution We recommend the use of a new shaft seal, an O-ring and bushing for reassembly.

Before insertion, moisten the new shaft seal slightly with a little vacuum pump oil.

Using a suitable plastic or aluminium cylinder (shaft seal driver) and a plastic hammer, force the shaft seal (12/9) carefully and without bending it into the centering disk (for position of shaft seal, see Fig. 12).

If you do not have a shaft seal driver, place the shaft seal on the opening in centering disk and carefully force it in with light blows of the plastic hammer. The shaft seal must not be bent.

Carefully push the bushing (12/8) into the shaft seal.

Push the centering disk (12/10) with the shaft seal and bushing onto the shaft and up against the end plate; fasten it with the hex. socket screws (12/11).

Push the O-ring (12/7) and the compression disc (12/6) onto the shaft.

Insert the key (12/5).

Mount the pump-half of the coupling (12/4) on the shaft.

Install the spring washer (12/3) and tighten the hex. screw (12/2).

Insert the coupling element (12/1) into the coupling and mount the motor (see Section 3.5).

Key to Fig. 13

- 1 Hex. nuts
- 2 Pump module
- 3 Washer
- 4 Gasket
- 5 Coupling element
- 6 Tie rods

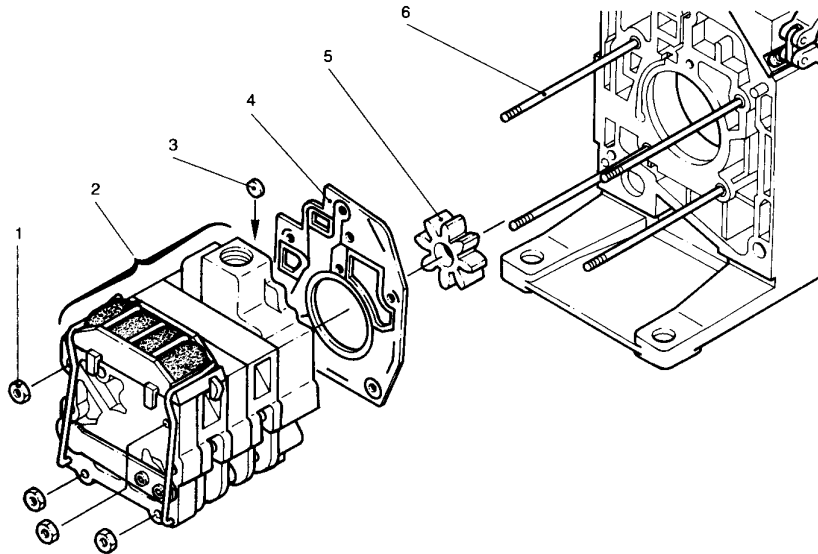

Fig. 13 Removing and remounting the pump module

3.7 Removing and Remounting the Pump Module

Required tools:

Allen keys 3 mm, 5 mm, 8 mm, box wrench 10 mm, possibly pliers.

3.7.1 Removing the Pump Module

Drain the oil and remove the oil case (see Section 3.4).

Unscrew the hex. nuts (13/1).

Pull the entire pump module (13/2) forward off the tie rods (13/6).

Caution When doing so, ensure that the individual pin-fitted parts are not loosened. Further disassembly of the pump module should only be carried out by a trained service engineer.

Remove the gasket (13/4).

Take the coupling element (13/5) off the coupling.

Caution After removing the protective shipping materials, handle the new pump module with care.

Before installing a new pump module, remove the four tie rods from the new module and insert them in the old one for protection during shipment.

3.7.2 Remounting the Pump Module

When installing a new pump module, it is also advisable to use a new gasket (13/4).

Check the coupling element (13/5) for damage; if necessary, install a new one.

Use the tie rods supplied with the new pump module only if the old ones are damaged. To do so, unscrew the old tie rods with lock nuts, and screw in the new ones. With the aid of the lock nuts, tighten the tie rods. Then remove the lock nuts.

Before mounting the pump module, make sure that sealing disc (13/3) fits correctly in its bore.

Push the gasket (13/4) onto the tie rods (13/6). Push the coupling element (13/5) onto one coupling half.

Push the entire pump module (new or repaired) onto the tie rods.

Caution Screw on the hex. nuts (13/1) and carefully cross-tighten them (torque 7.5 Nm).

Mount the oil case together with the gasket (see Section 3.4).

Fill in oil.

3.8 Leybold Service

If a pump is returned to Leybold, indicate whether the pump free of substances damaging to health or whether it is contaminated.

If it is contaminated also indicate the nature of the hazard. For this you must use a form which has been prepared by us which we will provide upon request.

A copy of this form is reproduced at the end of these Operating Instructions: "Declaration of Contamination of Vacuum Instruments and Components".

Please attach this form to the pump or enclose it with the pump.

This "Declaration of Contamination" is required to meet German Law and to protect our personnel.

Leybold must return any pumps without a "Declaration of Contamination" to the sender's address.

Warning The pump must be packed in such a way, that it will not be damaged during shipping and so that any contaminants are not released from the package.



3.8.1 Waste Disposal of Used Pump Materials

The corresponding environmental and safety regulations apply. This applies equally to used filters and filter elements (oil filter, exhaust filter and dust filter).

Warning – In the case of hazardous substances determine the kind of hazard first and observe the applicable safety regulations. If the potential hazard still persists, the pump must be decontaminated before starting with any maintenance work. For professional decontamination we recommend our Leybold service.



– Never exchange the oil or the filters while the pump is still warm. Let the pump cool down to uncritical temperatures first. You must wear suitable protective clothing.

3.9 Storing the Pump

Caution Before putting a pump into operation once more it should be stored in a dry place preferably at room temperature (20 °C). Before the pump is shelved it must be properly disconnected from the vacuum system, purged with dry nitrogen and the oil should be changed too.

The inlets and outlets of the pump must be sealed with the shipping seals which are provided upon delivery.

The gas ballast switch must be set to the "0" position and if the pump is to be shelved for a longer period of time it should be sealed in a PE bag containing some desiccant (silica gel).

When a pump is put into operation after it has been shelved for over one year, standard maintenance should be run on the pump and the oil should also be exchanged (see Operating Instructions). We recommend that you contact the Leybold service.

3.10 Troubleshooting

Fault	Possible cause	Remedy	Repair*
Pump does not start.	Wiring is malfunctioning. Motor protection switch incorrectly set (3-phase motors only). Operating voltage does not match motor. Motor is malfunctioning. Oil temperature is below 12 °C. Oil is too viscous. Exhaust filter/exhaust line is clogged. Pump is seized up (sign: pump is jammed).	Check and repair wiring. Set motor protection switch properly. Replace the motor. Replace the motor. Heat the pump and pump oil or use different oil. Change the oil. Replace the filter or clean the exhaust line. Repair the pump.	– 2.3 3.5 3.5 2.5.3/3.2 3.2 – Service
Pump does not reach ultimate pressure.	Measuring technique or gauge is unsuitable. External leak ¹⁾ . Anti-suckback valve is malfunctioning. Exhaust valve is malfunctioning. Oil is unsuitable. Intake line is dirty. Pump is too small.	Use correct measuring technique and gauge. Measure the pressure directly at pump's intake port. Repair the pump. Repair the valve. Repair the valve. Change the oil (degas it, if necessary). Clean the intake line. Check the process data; replace the pump, if necessary.	– Service Service Service 3.2 – –
Pumping speed is too low.	Dirt trap in the intake port is clogged. Exhaust filter is clogged. Connecting lines are too narrow or too long.	Clean the dirt trap; Precaution: install a dust filter in intake line. Install a new filter element. Use adequately wide and short connecting lines.	3.3 – 2.2
After switching off pump under vacuum, pressure in the system rises too fast.	System has a leak. Anti-suckback valve is malfunctioning.	Check the system. Repair the valve.	– Service
Pump gets hotter than usually observed.	Cooling air supply is obstructed. Ambient temperature is too high. Process gas is too hot. Oil level is too low. Oil is unsuitable. Oil cycle is obstructed. Exhaust filter/exhaust line is obstructed. Exhaust valve is malfunctioning. Pump module is worn out. Deviating mains voltage.	Set pump up correctly. Set pump up correctly. Change the process. Add oil. Change the oil. Clean or repair the oil lines and channels. Replace the exhaust filter, clean the exhaust line. Repair the valve. Replace the pump module. Check the motor voltage and the available mains voltage.	2.1 2.1/2.5.3 – 3.1 3.2 Service – Service 3.7
Oil in the intake line or in vacuum vessel.	Oil comes from the vacuum system. Anti-suckback valve is obstructed. Sealing surfaces of anti-suckback valve are damaged or dirty. Oil level is too high.	Check the vacuum system. Clean or repair the valve. Clean or repair the intake port and anti-suckback valve. Drain the excess oil.	– Service Service 3.1
Oil is turbid.	Condensation.	Degas the oil or change the oil and clean the pump. Precaution: open the gas ballast valve or insert a condensate trap.	2.5.2/3.2
Pump is excessively noisy.	Oil level is much too low (oil is no longer visible). Silencing nozzle is clogged. Intake pressure is too high. Internal demister is clogged. Coupling element is worn. Vaness or bushings are damaged.	Add oil. Clean the silencing nozzle or replace it. Lower the intake pressure. Clean or replace demister. Install new coupling element. Repair pump.	3.1/3.2 Fig. 10 – 3.4 3.5/3.6 Service

* Repair information: refer to the Section in the Operation Instruction stated here.

1) Bubble test: The warm pump with degassed oil is running without gas ballast and the intake blanked off. The exhaust line is lead into a vessel with water. If an evenly spaced line of bubbles appears, then the pump has an external leak.

Key to the maintenance plan - see 3.11

VE = Maintenance before switching on the system
VP = Maintenance before starting production
t = Daily maintenance
6m = Six monthly maintenance
a = Annual maintenance
n-a = Maintenance every n years.

We recommend that you service the pump every two years covering the following:

- Cleaning
- Checking of the individual components
- Exchange of all seals
- Functional check.

This check should be run by the Leybold service.

3.11 Maintenance Plan (Recommendation)

No.	Rotary vane pumps TRIVAC D 4 B TRIVAC D 8 B	Measurement/test quantity Operating/auxiliary materials	Interval						Remarks
			VE	VP	t	6m	a	n-a	
								Refer also to the Operating Instructions – Chapter: individual components.	
1	Operate the pump for at least 0.8 hours with gas ballast.				x			Condensed water is thus removed from the oil.	
2	Check the oil level, change the oil if required.	Oil: N 62 or special alternative oils	x		x			Refill: only after the pump has been switched off.	
3	Check the quality of the oil, change the oil if required.	visually chemically mechanically	x		x			Visually: normally light and transparent, oil change is required when discolorations increase. Chemically: to DIN 51558 when the neutralisation number exceeds 2; then an oil change will be required. Mechanically: when dynamic viscosity at 25 °C exceeds 240 mPas; then an oil change will be required. Disposal of waste oil: see Chapter 3.8.1 and 5.2	
4	Clean the dirt trap in the intake port, change it as required.	Suitable cleaning agent and compressed air.				x		<input type="checkbox"/> Clean dirt trap with a cleaning agent and blow it out with compressed air under a suction hood. <input type="checkbox"/> Replace the defective dirt trap. Use a cleaning agent which complies with the national / international specifications. Observe the safety regulations when using cleaning agents.	
5	Clean the internal demister, change it as required.	Suitable cleaning agent.					x	Already clean before the maintenance interval has elapsed when the noise level increases. <input type="checkbox"/> Clean the internal demister using a cleaning agent. <input type="checkbox"/> Replace the defective internal demister. <input type="checkbox"/> Dispose of the defective internal demister as special waste. Cleaning agent according to national / international specifications. Observe the safety regulations when using cleaning agents.	
6	Check the edges of the teeth on the coupling element for any damages, change the coupling element as required.						x		
7	Change the oil - and clean the oil level glass.	Oil: N 62 or special and alternative oils. See Chapter 1.6.1. Suitable cleaning agent and compressed air.					x	Oil change: • First oil change after 100 operating hours. • Pump switched off and cold. Change the oil when the pump is cold in order to avoid releasing absorbed gases. <input type="checkbox"/> Clean the oil level glass with a cleaning agent and blow it out with compressed air under a suction hood. Cleaning agent according to national / international specifications. Observe the safety regulations when using cleaning agents. Quantity of oil: see Operating Instructions, Chapter 1.6. Waste disposal of oil: see Operating Instructions, Chapter 3.8.1.	
8	Check the fan of the pump and the motor as well as the cooling fins on the motor for deposits and clean as required.	Brush and industrial vacuum cleaner.					x	Already clean before the maintenance interval has elapsed when the pump or the motor gets too warm. Caution: switch off the pump and ensure that it can not run up inadvertently (disconnect from the mains).	



EEC Declaration of Conformity



We – LEYBOLD Vakuum GmbH – herewith declare that the products defined below meet the basic requirements regarding safety and health of the relevant EC directives by design, type and versions which are brought into circulation by us.

In case of any product changes made without our approval, this declaration will be void.

Designation of the products: Rotary vane pump
- dual stage

Types: TRIVAC B
D 4 B / D 8 B

Cat. Nos.:

112 45; 112 46; 112 55; 112 56

113 03; 113 04; 113 06; 113 08; 113 09;

113 13; 113 14;

113 16; 113 18; 113 21

The products conform to the following directives:

- EC Directive on Machinery (98/37/EG)
- EC Directive on Low-Voltages (73/23)+(93/68/EWG)
- EC EMC Directive (89/336/EWG)
(91/263/EWG) + (92/31/EWG) + (93/68/EWG)

Applied harmonised standards:

- DIN EN 292 Part 1 11.91
- DIN EN 292 Part 2 06.95
- DIN EN 1012 Part 2 07.96
- DIN EN 60 204 Part 1 11.98

Applied national standards and technical specifications:

- DIN 31 001 April 1983

Cologne, June 20, 2001

K. Kilian, Business Area Manager LPV
Division Industrial

Cologne, June 20, 2001

Dr. Bahnen, Head of R&D LPV
Division Industrial

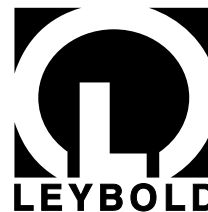

EEC Manufacturer's Declaration

in the sense of the Directive on Machinery 89/392/EWG, Annex IIb

We – Leybold Vacuum GmbH – herewith declare that operation of the incomplete machine defined below, is not permissible until it has been determined that the machine into which this incomplete machine is to be installed, meets the regulations of the EEC Directive on Machinery.

Applied harmonised standards:

- DIN EN 292 Part 1 11.91
- DIN EN 292 Part 2 06.95
- DIN EN 1012 Part 2 07.96
- DIN EN 60 204 Part 111.98

Designation of the products: Rotary vane pump
- dual stage

Applied national standards and technical specifications:

- DIN 31 001 April 1983
- DIN ISO 1940 Dec. 1993

Types: TRIVAC B
D 4 B without motor
D 8 B without motor

Cat. Nos.: 113 07
113 17

Cologne, June 20, 2001

K. Kilian, Business Area Manager LPV
Division Industrial

Cologne, June 20, 2001

Dr. Bahnen, Head of R&D LPV
Division Industrial



Sales Net worldwide

AMERICA

USA:

LEYBOLD VACUUM USA
5700 Mellon Road
Export, PA 15632
Phone: +1-724-327 57 00
Fax: +1-724-733 12 17
Internet: <http://www.leyboldvacuum.com>

Canada:

LEYBOLD Canada Inc.
7050 Telford Way, Unit 5
Mississauga, Ontario
Canada L5S 1V7
Phone: +1-905-672 77 04
Fax: +1-905-672 22 49
e-mail:
reachus@leybold.on.ca

EUROPE

Deutschland:

LEYBOLD VAKUUM
GmbH
Bonner Straße 498
D-50968 Köln
Phone: +49-221-347-1234
Fax: +49-221-347-12 45
Internet: www.leyboldvac.de
e-mail:
sales@leyboldvakuu.com

Belgien/Niederlande/ Luxemburg:

LEYBOLD N.V.
Leuvensesteenweg 542, 9A
B-1930 Zaventem
Phone: +32-2-71 10 083
Fax: +32-2-72 08 338

LEYBOLD B.V.

Computerweg 7
NL-3606 AV Maarssen
Phone: +31-346-583 999
Fax: +31-346-583 990

Frankreich:

LEYBOLD S.A.
7, Avenue du Quebec
Z.A. de Courtaboeuf, B.P. 42
F-91942 Courtaboeuf Cedex
Phone: +33-1-69 82 48 00
Fax: +33-1-69 07 57 38
e-mail:
Compuserve:100635,43

Groß-Britannien/Irland:

LEYBOLD LTD.
Waterside Way,
Plough Lane
GB-London SW 17 OHB
Phone: +44-208-971 70 00
Fax: +44-208-971 70 01

Italien:

LEYBOLD S.P.A.
Via Trasimeno 8
I-20128 Milano
Phone: +39-02-27 22 31
Fax: +39-02-27 20 96 41

Spanien:

LEYBOLD S.A.
C/. Mataró, 27
Polígono Industrial Les
Grases
E-08980 Sant Feliu de
Llobregat (Barcelona)
Phone: +34-93-666 46 16
Fax: +34-93-666 43 70

Schweden:

LEYBOLD AB
Box 9084
40092 Göteborg
Phone: +46-31-68 84 70
Fax: +46-31-68 39 39

Schweiz/ Liechtenstein:

LEYBOLD AG
Leutschenbachstraße 55
CH-8050 Zürich
Phone: +41-1-308 40 50
Fax: +41-1-302 43 73

ASIA

Volksrepublik China:

LEYBOLD (Tianjin)
VACUUM EQUIPMENT
MANUFACTURING Co.,
Ltd.
Beichen Economic
Development Area (BEDA)
Tianjin 300400, China
Phone: +86-22 26 972 016
Fax: +86-22 26 972 017
e-mail:
leybold@public.tpt.tj.cn

Japan:

LEYBOLD Co., Ltd.
Head Office
Tobu A.K. Bldg. 4th Floor
23-3, Shin-Yokohama 3-
chome
Kohoku-ku, Yokohama-shi
Kanagawa ken 222-0033
Phone: +81-45-471 33 30
Fax: +81-45-471 33 23

Korea:

LEYBOLD Korea Ltd.
4th Fl. Shinan Bldg., 173-1
Jangchoog-dong 2ga,
Choong-ku
Seoul 100-392, Korea
C.P.O. Box 709
Phone: +82-2-227 11 567
Fax: +82-2-227 11 568

Singapore:

BALZERS and LEYBOLD
Singapore Pte. Ltd.
1 Tuas South Street 3
Singapore 638043
Phone: +65-865 18 65
Fax: +65-862 22 95

Taiwan:

LEYBOLD Taiwan, Ltd.
2 F, No 416-1, Sec. 3
Chung-Hsin Rd.
Chu Tung, Hsinchu.
Taiwan R.O.C: 310
Phone: +886-3-583 39 88
Fax: +886-3-583 39 99



LEYBOLD VACUUM GmbH

Bonner Strasse 498 (Bayenthal)
D-50968 Cologne
Tel.: +49(0)221 347-0
Fax: +49(0)221 347-1250
<http://www.leyboldvac.de>
e-mail: documentation@leyboldvac.de

GA 01.201/9.02 - 06/01