Magnetically Levitated Turbo Molecular Pump

- Model:TMP-3203M** (Air cooled type)
Model:TMP-3203MC (Air cooled chemical type)
Model:TMP-3203LM (Wide range type)
Model:TMP-3203LMC (Wide range chemical type)
Model:TMP-3403LMC (Wide range chemical type)

INSTRUCTION MANUAL

	FOR SALES AND SERVICE PLEASE CALL:
	PTB SALES ☎ :: 626.334.0500 service@ptbsales.com www.ptbsales.com
	DATE SERVICED: _____

VIEW OUR INVENTORY

Read the instruction manual thoroughly before you use the product.
Keep this instruction manual for future reference.

SHIMADZU CORPORATION
Semiconductor Equipment Division



Introduction

Thank you for choosing the turbo molecular pump made by Shimadzu Corporation. (hereafter referred to as "turbo molecular pump").

Please read the instruction manual carefully in conjunction with the instruction manual of "Power Supply Unit" before using turbo molecular pump, and save the instruction manual for future reference.

Copyrights and Disclaimers

This document is copyrighted by Shimadzu Corporation. Please refrain from reproducing or copying part or all of this document without permission from Shimadzu.

In an effort to improve the product, this document may be revised in the future without notice.

Every effort has been made to prepare an accurate and complete manual, but if an error or omission should be discovered, revisions might not be possible immediately.

Shimadzu does not take responsibility for any effects that may result from the use of this manual.

Copyright © 2003-2006 Shimadzu Corporation. All rights reserved.

Precautions for Safe Operation

The instruction manual's nomenclature for warnings and precautions complies with the following safety warning symbols.

WARNING

Indicates a potentially hazardous situation which, if not avoided, could result in serious injury or possibly death.

CAUTION

Indicates a potentially hazardous situation which, if not avoided, may result in minor to moderate injury or equipment damage.

NOTICE

Emphasizes additional information that is provided to ensure the proper use of this product.

WARNING

Turbo molecular pump repair and/or power supply repair can be very hazardous. Only trained technicians who are authorized by Shimadzu may do service of products.

**WARNING**

Neither overhaul nor modify the pump proper and power supply unit without admission. Doing so would impair safety of the pump proper.

**WARNING**

Decisions on system compatibility should be made by the system designer or the person deciding the specifications after conducting tests as necessary. The responsibility for guaranteeing the expected performance and safety of the system lies with the person who decides system compatibility.

WARNING

- Fix the pump to the device according to 5.1.2.1 and 5.1.2.2. The method to fix the pump is different depending on the pump model and the size of inlet flange of the pump.
 - The device should be fixed to the floor so as not to move. The device should be designed to endure the torque 1.5 times the rapid shutdown torque to take the safety margin in preparation for an emergency accident.
 - The rotor assembly of the turbo molecular pump rotates at high speed. Large rapid shutdown torque should be generated when abnormality occurs in the pump by any chance. Incidental accident will cause the pump to drop out and to make a catastrophe if the pump is fixed by insufficient method.
-
-

WARNING

Do not remove the turbo molecular pump, before safety has been confirmed.

Improper turbo molecular pump use may be hazardous to operator's health in applications not recommended or approved by Shimadzu. In the event removal of the turbo molecular pump from an application is required, full protective measures including purging of the turbo molecular pump with an inert gas and/or apparel are recommended when the turbo molecular pump has been used in applications that required the use of corrosive, reactive, stimulative, or toxic gases.

CAUTION

After having operated the turbo molecular pump for evacuation of corrosive gas, keep the pump internal as vacuumed even after shutdown. Inflow of water content in the air to the pump internal would cause rapid erosion trouble of the pump internals.

CAUTION

Avoid to install the pump at the following places.

- (1) Place where the pump is inevitably exposed to significant vibration and impact.
- (2) Unstable place.
- (3) Place where the pump is inevitably exposed to magnetic field and radioactive ray.

The pump proper is a precision machine. Be careful not to apply abnormal vibration, shock/ impact to it during transportation. This pump is not connected to grand. Please provide PE(Protective earth) connection to the chassis of pump in final application.

CAUTION

The following "CAUTIONS" are to prevent operation anomalies.

1. This turbo molecular pump is not approved for use in applications exhausting process gas containing gallium (Ga, e.g., triethyl gallium, etc.).
 2. Protect the pump from any and all types of impact during operation.
 3. Do not operate any equipment (i.e. drill motor, welding machine, etc.) that produces electromagnetic pollution, noise, etc., in the immediate proximity of an operating turbo molecular pumping system (pump, power supply, cables, etc).
 4. Do not interrupt the electrical power operating the turbo molecular pump while the turbo molecular pump is in operation.
 5. Do not connect or disconnect the turbo molecular pump control cable during the time the power supply is "ON".
 6. Be sure to use the chemical type pumps to exhaust of gas which contain chlorine, or fluorine.
 7. Plasmas may cause the pump rotor to discharge electrically thus damaging the electrical components.
 8. When using the variable speed function to change the pump rotation rate, use a rotation rate that does not cause resonance with other devices installed at the site.
-
-

○ Explanation of label



- (1) HOT SURFACE label
 Risk of burn. Keep off from touching surface of the pump as it is heated.

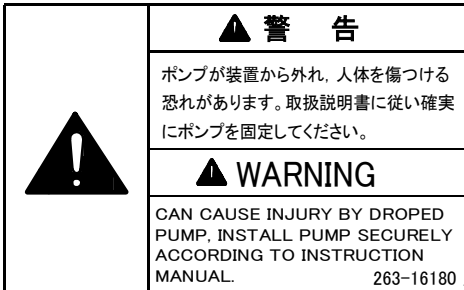

- (2) INSTALL PUMP label
 Incidental accident will cause the pump to drop out and to make a catastrophe if the pump is fixed by insufficient method.
 Fix the pump to the device according to 5.1.2 「Installation of the Pump」 .



- (3) SECURITY seal
 This label certifies that the product was made or maintained by Shimadzu or by Shimadzu authorized facility .
 In case "this label is removed" or "there is a mark showing once this label has been removed", Shimadzu warranty shall not be applied to the product.

○ Location of label

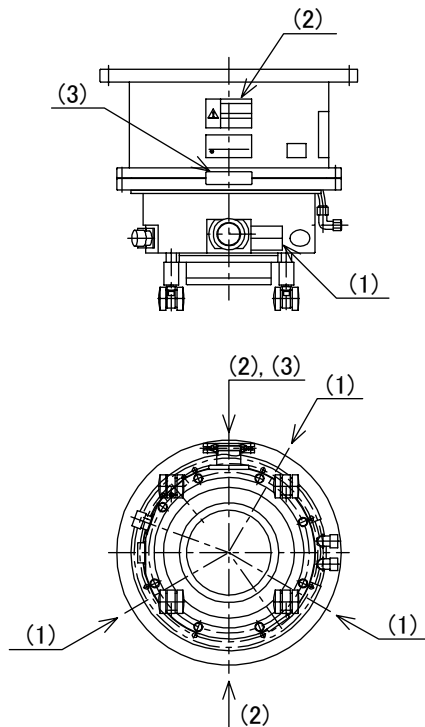

Series of TMP-3203 and TMP-3403LMC

Label attachment phase

○ Installation Precautions

Do not apply abnormal loads to the turbo molecular pump control cable plug and/or connector. Abnormal loads may cause cable disconnection.

- (1) Do not pull the turbo molecular pump control cable by the connector or plug.



- (2) Do not allow any electrical cables to be in tension or to have very tight bending radii.



- (3) Do not twist the turbo molecular pump control cable during connection.



○ Part Replacement

The lifetime of parts are specified as below.

The request for changing parts exceeding the estimated lifetime should be made to Shimadzu or an approved service company in order for safety and adequate performance of the pump and power supply unit.

Table 1 Estimated Part Life.

Parts List	Estimated Part Life
Cooling fan	5 years

○ Air Cooled Turbo Molecular Pump

For the air cooled turbo molecular pumps, it is necessary to clean the cooling fan periodically because of the cooling fan collecting dust, debris, etc. Shimadzu recommends removal of the cooling fan for all methods of cleaning (compressed air, etc.) to prevent the particles, cleaning debris, from accumulating in or on the turbo molecular pump. Please refer to Fig. 1 how to change fan.

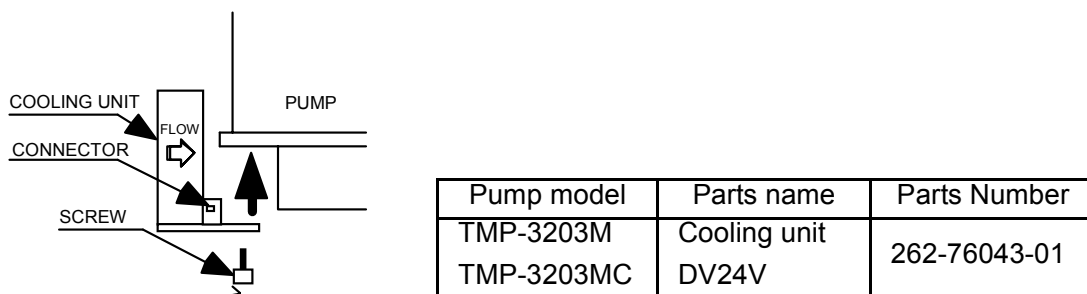

Fig. 1 How to Change the Cooling Fan Unit

○ Warranty period

12 months on new TMP's from the date of shipment from Shimadzu, or from any of its worldwide sales offices.

○ Conditional warranty

During the warranty period and under normal operation, if the TMP fails to meet its product specification due to defects in material and/or workmanship, Shimadzu will, at its discretion, either repair it or exchange it with a new one for free.

○ Scope of the warranty

The warranty covers only TMPs, controllers and accessories sold by Shimadzu.

○ Warranty of repaired or replacement parts

In-warranty repaired or replacement parts are warranted only for the remaining unexpired portion of the original warranty period applicable to the parts that have been repaired or replaced.

○ Exemption from the warranty

During the warranty period, Shimadzu will charge for repair or exchange in the following cases:

- 1) Failure caused by natural disasters or fire.
- 2) Failure or functional deterioration due to the following:
 - a) Pumping of special gases and materials
 - b) Ingestion of foreign objects through the TMP's protective net
 - c) TMP is operated differently than what is prescribed in the instruction manual

- 
- d) When Shimadzu determines through failure analysis that the cause of failure was due to abnormal operation or external circumstances. our engineers judge that the cause of the trouble is an irregular operation
- 3) Warranty is voided if the "Security Seal" on the product has been removed, hampered with, or altered.

○ Disposal of Products and Parts

Please contact Shimadzu for proper disposal of its products or parts. There is a possibility to pollute the environment with the material of the parts, when you dispose this product in an inappropriate way.

○ LIMITATION OF LIABILITY

EXCEPT AS STATED HEREIN, SHIMADZU MAKES NO WARRANTY, EXPRESSED OR IMPLIED (EITHER IN FACT OR BY OPERATION OF LAW), STATUTORY OR OTHERWISE: AND, EXCEPT AS STATED HEREIN, SHIMADZU SHALL HAVE NO LIABILITY FOR SPECIAL OR CONSEQUENTIAL DAMAGES OF ANY KIND OR FROM ANY CAUSE ARISING OUT OF THE SALE, INSTALLATION, OR USE OF ANY OF ITS PRODUCTS.

TABLE OF CONTENTS

Introduction

Copyrights and Disclaimers	i
Precautions for Safe Operation	ii
○ Explanation of label	v
○ Location of label	v
○ Installation Precautions	vi
○ Part Replacement	vi
○ Air Cooled Turbo Molecular Pump	vii
○ Warranty period	vii
○ Conditional warranty	vii
○ Scope of the warranty	vii
○ Warranty of repaired or replacement parts	vii
○ Exemption from the warranty	vii
○ Disposal of Products and Parts	viii
○ LIMITATION OF LIABILITY	viii
TABLE OF CONTENTS	ix

Section 1 OUTLINE AND DESCRIPTIONS

1.1 Outline	2
1.2 Descriptions	3
1.2.1 Outside drawing of Pump Main Unit	3
1.2.1.1 Outside drawing of series of TMP-3203	3
1.2.1.2 Outside drawing of TMP-3403LMC	5
1.2.2 Standard Accessories	6

Section 2 IDENTIFICATION AND FUNCTION

2.1 Pump Main Unit	8
------------------------------	---

Section 3 CONSTRUCTION AND PRINCIPLE

3.1 Pump Construction	10
3.2 Principle of Turbo Molecular Pumping	10

Section 4 SPECIFICATIONS

4.1 Pump Main Unit	14
4.1.1 Specification of series of TMP-3203	14
4.1.2 Specification of TMP-3403LMC	15
4.2 Standards Fulfilled	16

Section 5 INSTALLATION

5.1 Installation	18
5.1.1 Pump Mounting Direction	18
5.1.2 Installation of the Pump	19
5.1.2.1 Installation of series of TMP-3203	21
5.1.2.2 Installation of TMP-3403LMC	23
5.1.3 Example of piping connection	24
5.1.4 Center of gravity of the pump	25
5.2 Connection of the Pump to the Power Supply Unit	26
5.3 Interlock for Vacuum System	27

Section 6 OPERATION

6.1 Outline	30
6.1.1 Introduction	30
6.2 Start-up Preparation	31
6.2.1 Start-up Preparation	31
6.3 Start-up	31
6.3.1 Start-up Sequence	31
6.4 Shutting Down	32
6.5 Baking Operation	34

Section 7 GAS PURGE

Section 8 TURBO MOLECULAR PUMP RECONDITION

8.1 Turbo Molecular Pump Return Request	40
8.2 Turbo Molecular Pump Decontamination.	41
8.3 Touch-Down Bearing Replacement.	41
8.4 Check of the rotor blades.	41

Section 9 TROUBLESHOOTING

9.1 Vacuum Pressure Rise	44
9.2 Abnormal Noise and/or Vibration	44

This page is intentionally left blank.

OUTLINE AND DESCRIPTIONS

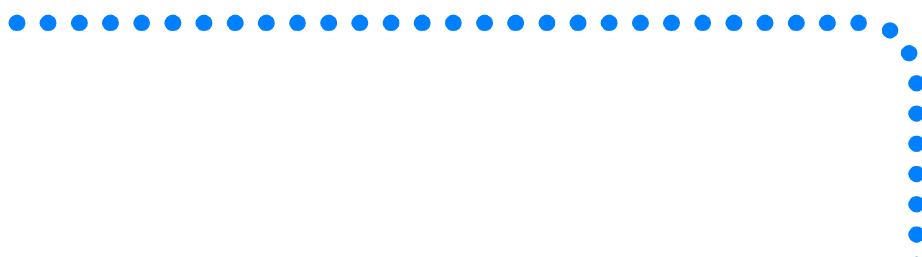

- 1.1 Outline
- 1.2 Descriptions
 - 1.2.1 Outside drawing of Pump Main Unit
 - 1.2.1.1 Outside drawing of series of TMP-3203
 - 1.2.1.2 Outside drawing of TMP-3403LMC
 - 1.2.2 Standard Accessories

1.1 Outline

The turbo molecular pump is a vacuum pump. The turbo molecular pump is used with a backing vacuum pump to create a high vacuum in a vacuum chamber.

Typical Applications ; Semiconductor equipments,
Industrial equipments,
R&D applications,
The other ultra high vacuum applications.

The turbo molecular pump (one standard set) consists of the following items.

- Pump 1
- Power Supply Unit 1
- Control Cable 1
- Motor Cable 1
- Standard Accessories 1 Set

This instruction manual explains the operation of the pump unit. For more detailed instructions regarding the power supply unit, please refer to the Power Supply Unit Instruction Manual.

1.2 Descriptions

1.2.1 Outside drawing of Pump Main Unit

1.2.1.1 Outside drawing of series of TMP-3203

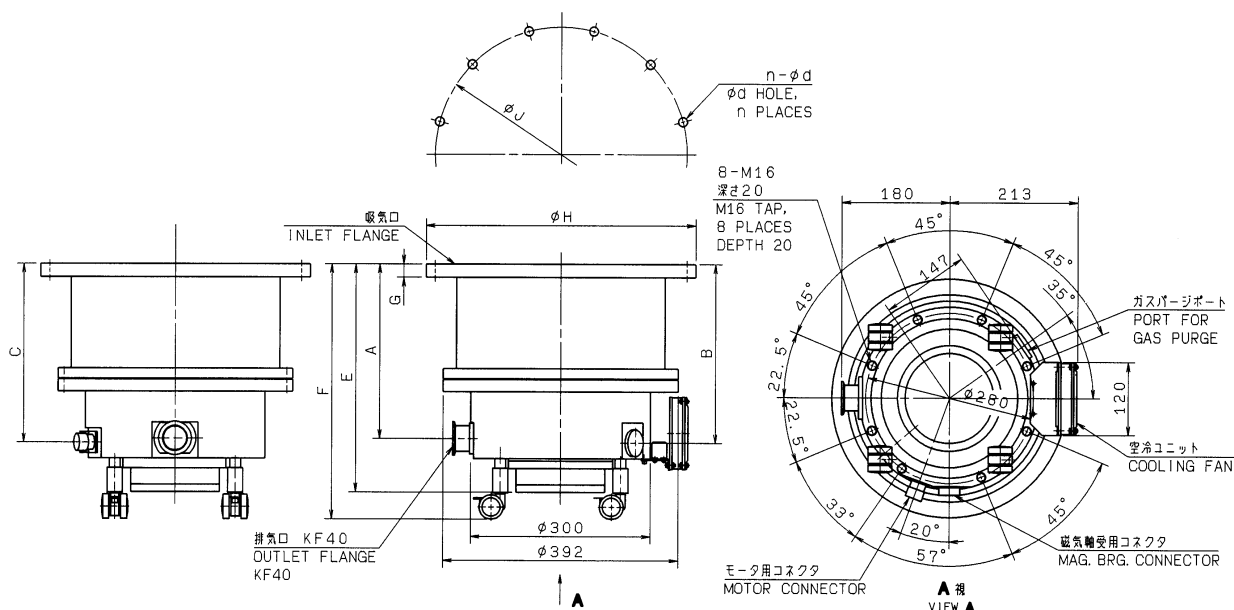

INLET FLANGE	Parts number		A	B	C	E	F	G	φH	φJ	n-φd
	TMP-3203M	TMP-3203MC									
VG350	P/N 262-78430-62	P/N 262-78430-72	287	294	289	375	420	22	φ450	φ420	12-φ15
ISO320B Special	P/N 262-78430-63	P/N 262-78430-73	287	294	289	375	420	22.5	φ425	φ395	12-φ13
VG300	P/N 262-78430-67	P/N 262-78430-77	307	314	309	395	440	18.5	φ400	φ370	12-φ13
VG250	P/N 262-78430-68	P/N 262-78430-78	331	338	333	419	464	18.5	φ350	φ320	12-φ13

Fig.1-1 TMP-3203M and TMP-3203MC

SECTION 1 OUTLINE AND DESCRIPTIONS

1

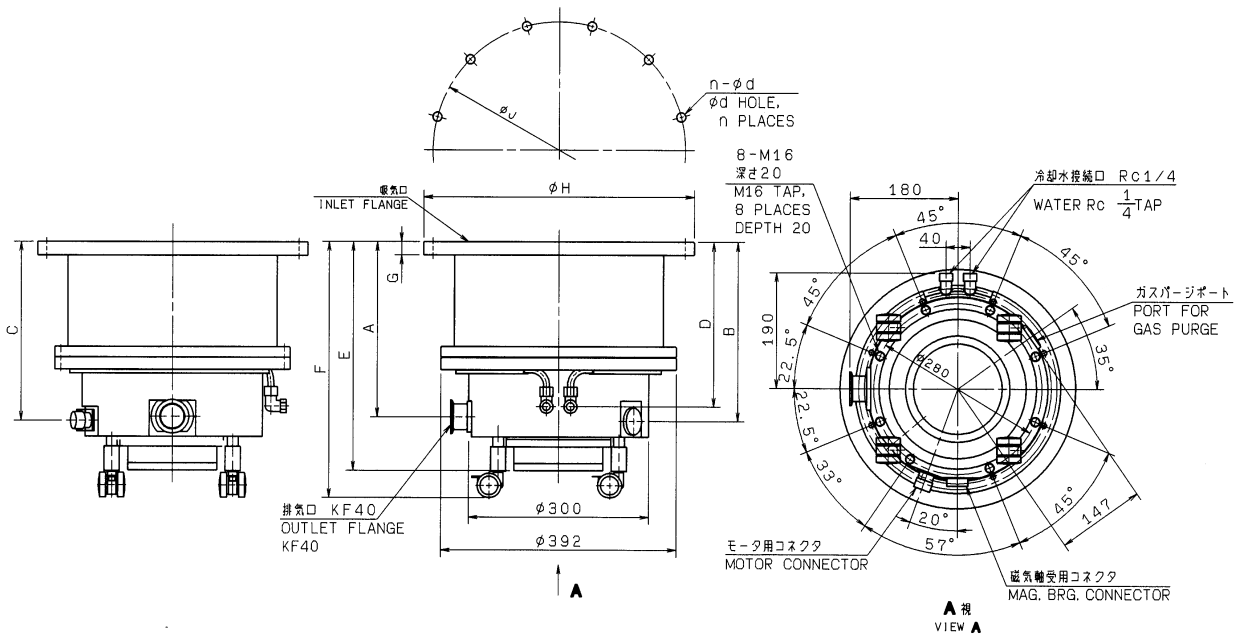

INLET FLANGE	Parts number		A	B	C	D	E	F	G	ϕH	ϕJ	$n-\phi d$
	TMP-3203LM	TMP-3203LMC										
VG350	P/N 262-78430-42	P/N 262-78430-52	287	294	289	270	375	420	22	$\phi 450$	$\phi 420$	12- $\phi 15$
ISO320B Special	P/N 262-78430-43	P/N 262-78430-53	287	294	289	270	375	420	22.5	$\phi 425$	$\phi 395$	12- $\phi 13$
VG300	P/N 262-78430-47	P/N 262-78430-57	307	314	309	290	375	440	18.5	$\phi 400$	$\phi 370$	12- $\phi 13$
VG250	P/N 262-78430-48	P/N 262-78430-58	331	338	333	314	419	464	18.5	$\phi 350$	$\phi 320$	12- $\phi 13$

Fig.1-2 TMP-3203LM and TMP-3203LMC

1.2.1.2 Outside drawing of TMP-3403LMC

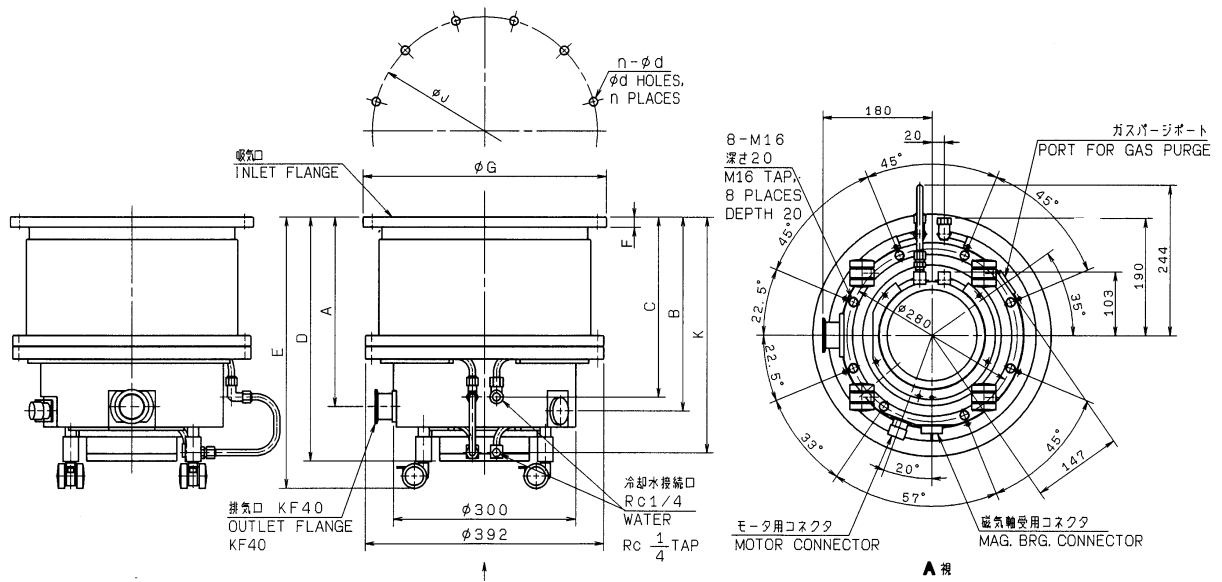

INLET FLANGE	Parts number	A	B	C	D	E	F	ϕG	K	ϕH	n- ϕd
VG350	P/N 262-78503-52	287	294	270	375	420	22	$\phi 450$	360	$\phi 420$	12- $\phi 15$
ISO320B Special	P/N 262-78503-53	287	294	270	375	420	22.5	$\phi 425$	360	$\phi 395$	12- $\phi 13$
VG300	P/N 262-78503-57	307	314	290	395	440	18.5	$\phi 400$	380	$\phi 370$	12- $\phi 13$
VG250	P/N 262-78503-58	331	338	314	419	464	18.5	$\phi 350$	404	$\phi 320$	12- $\phi 13$

Fig.1-3 TMP-3403LMC

1.2.2 Standard Accessories

Series of TMP-3203

	Description	Q'ty	Notes	Parts number
1	Gasket for inlet flange (Note)	1	O-ring gasket for VG350 O-ring gasket for VG300 O-ring gasket for ISO320B Special O-ring gasket for VG250	036-13516 036-13515 036-15554-55 036-13514
2	Bolt set for inlet flange (Note)	1	VG350 : Hex Head, M12 × 40, 12PC (A2-70) VG300 : Hex Head, M12 × 35, 12PC (12.9) ISO320B Special : Hex Head, M12 × 40, 12PC (12.9) VG250 : Stud Bolt, M12 × 47, 12PC (12.9)	—
3	Centering with O-ring	1	KF40	035-06004-14
4	Clamp	1	KF40	035-06004-03
5	Instruction manual	1	English	263-13236

TMP-3403LMC

	Description	Q'ty	Notes	Parts number
1	Gasket for inlet flange (Note)	1	O-ring gasket for VG350 O-ring gasket for VG300 O-ring gasket for ISO320B Special O-ring gasket for VG250	036-13516 036-13515 036-15554-55 036-13514
2	Bolt set for inlet flange (Note)	1	VG350 : Hex Head, M12 × 40, 12PC (12.9) VG300 : Hex Head, M12 × 35, 12PC (12.9) ISO320B Special : Hex Head, M12 × 40, 12PC (12.9) VG250 : Stud Bolt, M12 × 47, 12PC (12.9)	—
3	Centering with O-ring	1	KF40	035-06004-14
4	Clamp	1	KF40	035-06004-03
5	Instruction manual	1	English	263-13236

(Note) One of followings.

IDENTIFICATION AND FUNCTION



2.1 Pump Main Unit

2.1 Pump Main Unit

2

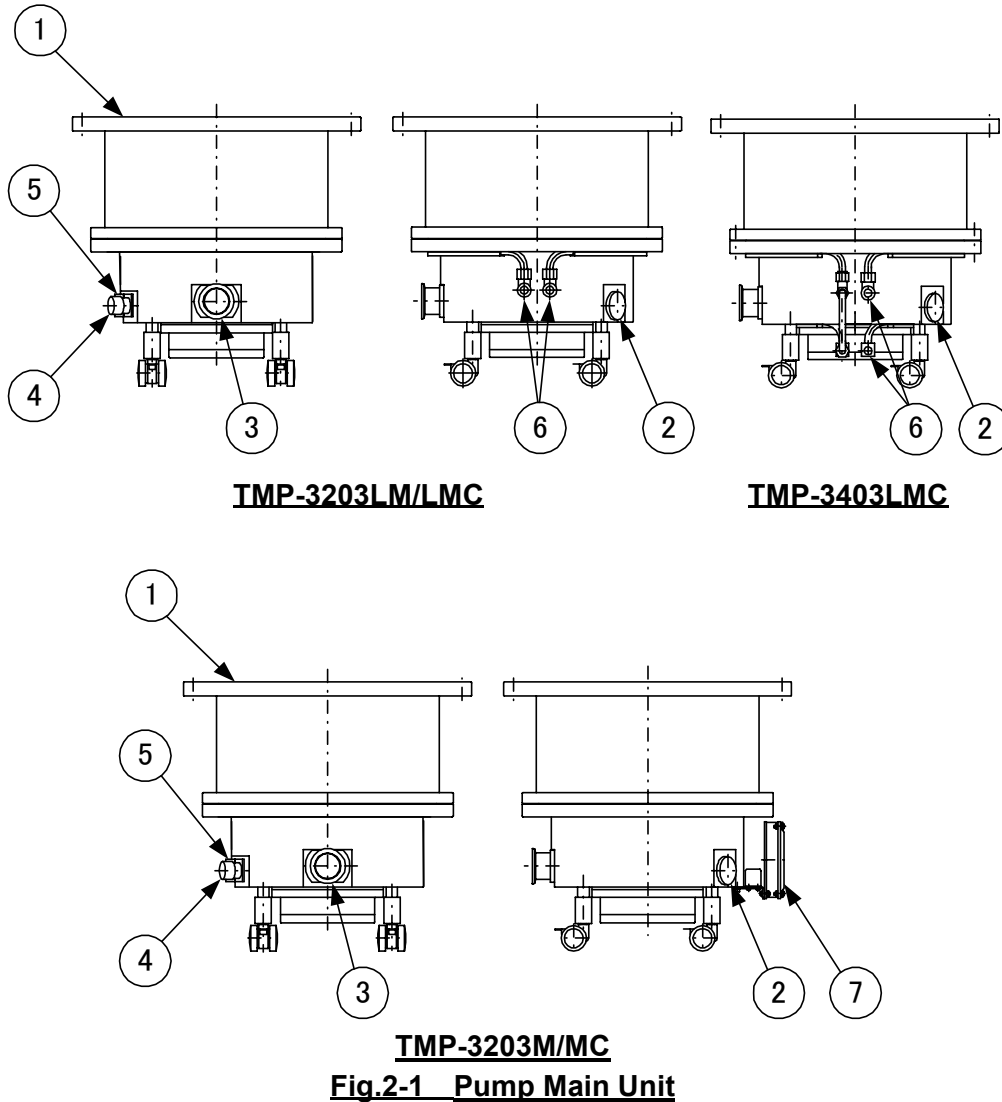

- (1) INLET FLANGE. Inlet flange, joint the turbo molecular pump, VG350, ISO320B Special, VG30, VG250 are also available.
- (2) PORT FOR GAS PURGE Gas purge adaptor port
(see Section 7 "GAS PURGE")
- (3) OUTLET FLANGE. Outlet flange, connect a backing vacuum pump or its related pipe connection, KF40.
- (4) MOTOR CONNECTOR. Motor cable receptacle
- (5) CONTROL CONNECTOR. Control cable receptacle
- (6) COOLING WATER PIPELINE. Cooling water pipe connector, Rc1/4
- (7) COOLING FAN Cooling Fan

CONSTRUCTION AND PRINCIPLE



- 3.1 Pump Construction
- 3.2 Principle of Turbo Molecular Pumping

3.1 Pump Construction

3

Fig. 3-1 is a sectional drawing of the TMP-3203LM and TMP-3203LMC and TMP-3403LMC magnetic bearing type turbo molecular pump. The built-in high frequency motor (1) is accelerated to the specified revolutions (speed) by the high frequency power supply unit. Rotor blades (4) are fitted onto the drive shaft (3) and the stator blades (5) are arranged in between the rotor blades. A positioning spacer (6) is inserted between the stator blades. The configurations and profiles of the stator blades and rotor blades are designed for high efficiencies in various applications. The upper stages of the rotor blade and stator blade configurations are ideally designed for high gas throughput. The compression ratio of the stator blades and rotor blades becomes higher as the gas molecules converge into the lower stage configurations. The profiles of the stator blades and rotor blades are matched for the desired function.

A radial magnetic bearing (7) is used at the top and bottom of the drive shaft. The axial magnetic bearings (8) are used to levitate a disk attached to the drive shaft between the axial magnetic bearings. Each magnetic bearing is provided with a gap sensor (10) to detect the rotor position. Fig. 3-2 illustrates the outline of 5 - axes control. The rotor is levitated by the control of these 5 axes allowing rotational freedom.

A touchdown bearing is used at the top and bottom of the casing for safety protection of the rotor and pump should the magnetic bearings become damaged. The touchdown bearings are dry and oil free.

The cooling water pipe (14) is provided to cool the pump. With the air-cooled turbo molecular pumps TMP-3203M and TMP-3203MC, cooling fans are provided instead of the cooling water pipe (14).

Fig. 1-1 through Fig. 1-3 show the outside dimensions of the turbo molecular pump.

3.2 Principle of Turbo Molecular Pumping

The principle of turbo molecular pumping assumes gas molecules collide with a surface plane (the blade of the pump rotor) moving in a radial span of very high speed in a space with an enlarged mean free gas path (generally a vacuum area of less pressure than 0.1 Pa). Assuming no heat is exchanged between the gas molecule and the pump rotor blade, the speed of the pump rotor blade is added to the speed of the gas molecule, converting the gas molecule's non-oriented thermal motion to a motion with direction. Thus the gas molecule has received an impulse in a desired flow direction.

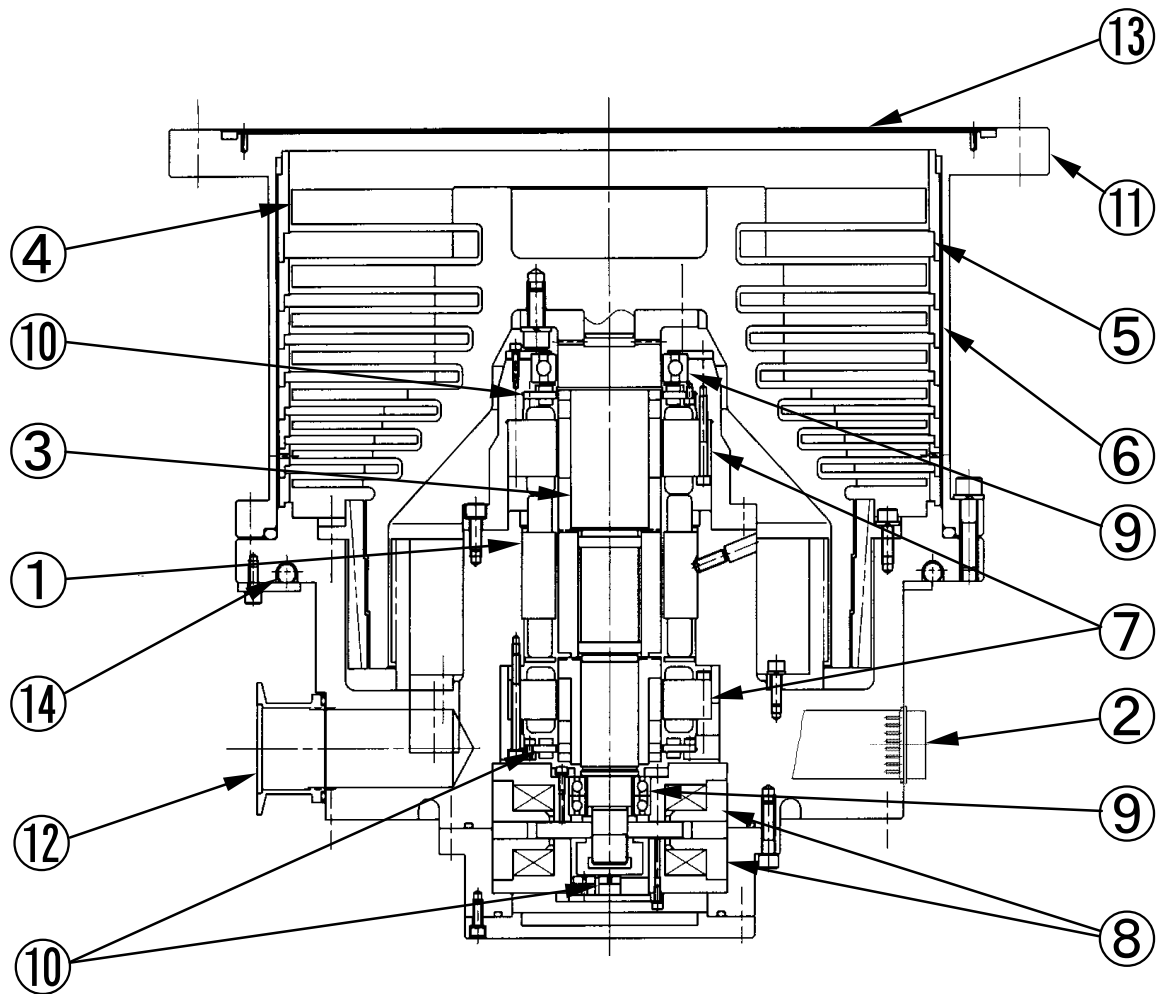

Fig.3-1 Pump Sectional Drawing

- | | | |
|--------------------------|-----------------------------|---|
| (1) High frequency motor | (6) Spacer | (11) Inlet flange |
| (2) Receptacle | (7) Radial magnetic bearing | (12) Outlet flange |
| (3) Drive shaft | (8) Axial magnetic bearing | (13) Protective net |
| (4) Rotor blade | (9) Touch-down bearing | (14) Cooling water pipeline
(pipe connection port) |
| (5) Stator blade | (10) Gap sensor | |

SECTION 3 CONSTRUCTION AND PRINCIPLE

3

The movement of an object has 6 degrees of freedom. Levitation can be achieved in a turbo molecular pump by controlling the following 5 degrees of freedom (excluding the rotational degree (Z axis) of freedom).

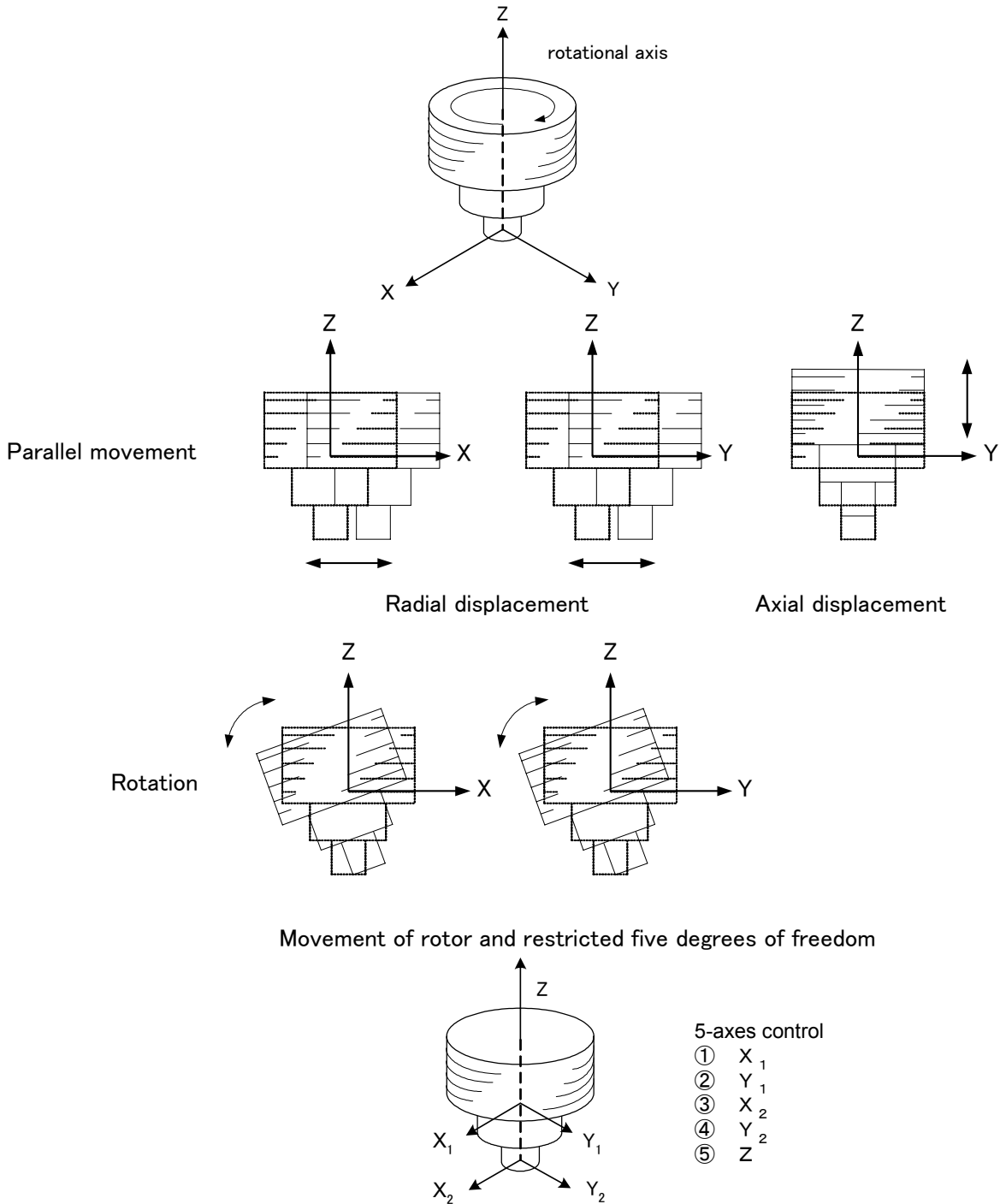

Fig.3-2 Outline of 5-Axes Control

SPECIFICATIONS



4.1 Pump Main Unit

4.1.1 Specification of series of TMP-3203

4.1.2 Specification of TMP-3403LMC

4.2 Standards Fulfilled

4.1 Pump Main Unit

4.1.1 Specification of series of TMP-3203

Turbo molecular pump model		TMP-3203M	TMP-3203MC	TMP-3203LM	TMP-3203LMC
Cooling method		Cooling fan		Water	
Ultimate pressure (Note 1)		10 ⁻⁹ Pa order	10 ⁻⁸ Pa order	10 ⁻⁹ Pa order	10 ⁻⁸ Pa order
Maximum Argon gas through put (Note 2)		250 mL/min	400 mL/min	1200 mL/min	2200 mL/min
Maximum allowable inlet pressure (Nitrogen gas)		0.4 Pa		40 Pa	
Maximum allowable outlet pressure		40 Pa		270 Pa	
Pumping speed (Note 3)	N ₂	3200 L/s			
	He	3000 L/s			
	H ₂	2400 L/s			
Compression ratio	N ₂	1 × 10 ⁹ or more			
	He	3 × 10 ⁵			
	H ₂	1 × 10 ⁴			
Rated speed		21000 rpm			
Start-up time		13 minutes			
Mounting position		In any desired direction (Note 4)			
Bake-out temperature at an inlet flange		120 °C or less			
Vibration level (by Shimadzu's method)		0.01 μm or less (0-peak)			
Inlet flange		VG350 (Note 5)			
Outlet flange		KF40			
Mass		70 kg			
Admissible throughput of purge gas		20 to 30 mL/min (Note 2)			
Admissible pumping speed of backing vacuum pump in case of gas purge		1500 L/min or more			
Environmental Temperatures		Operation : 0 to 40 °C / Storage : -25 to 70 °C			
Admissible ambient magnetic field					
Radial direction		3 mT			
Axial direction		15 mT			
Water	Flow rate	N/A		2 to 4 L/min	
	Pressure			0.2 to 0.5 MPa	
	Temperature			5 to 25 °C	

(Note 1) When using a metal gasket at the inlet flange. When using an o-ring gasket, the ultimate pressure is 10⁻⁷ Pa order.

(Note 2) mL/min : volume flow rate at 0 °C, 1 atm. (Compatible with SCCM.)

(Note 3) Without a protective net. Pumping speed for N₂ is 2950 L/s with a protective net.

(Note 4) The outlet flange of the turbo molecular pump should face horizontally or vertically when installing the pump horizontally and obliquely.

(Refer to 5.1.1 「Pump Mounting Direction」)

(Note 5) VG300, VG250 and ISO320B Special are also available.

4.1.2 Specification of TMP-3403LMC

Turbo molecular pump model	TMP-3403LMC	
Cooling method	Water	
Ultimate pressure	10 ⁻⁷ Pa order	
Maximum Argon through put (Note 1)	2200 mL/min	
Maximum allowable inlet pressure (Nitrogen gas)	10 Pa	
Maximum allowable outlet pressure	270 Pa	
Pumping speed (Note 2)	N ₂ He H ₂	3300 L/s 3100 L/s 2400 L/s
Compression ratio	N ₂ He H ₂	1 × 10 ⁹ 1 × 10 ⁵ 6 × 10 ⁴
Rated speed	22020 rpm	
Start-up time	15 minutes	
Mounting position	In any desired direction (Note 3)	
Bake-out temperature at an inlet flange	120 °C or less	
Vibration level (by Shimadzu's method)	0.01 μm or less (0-peak)	
Inlet flange	VG350 (Note 4)	
Outlet flange	KF40	
Mass	70 kg	
Admissible throughput of purge gas	20 to 30 mL/min (Note 1)	
Admissible pumping speed of backing vacuum pump in case of gas purge	1500 L/min or more	
Environmental Temperatures	Operation : 0 to 40 °C / Storage : -25 to 70 °C	
Admissible ambient magnetic field Radial direction Axial direction	3 mT 15 mT	
Water	Flow rate Pressure Temperature	2 to 4 L/min 0.2 to 0.5 MPa 5 to 25 °C

(Note 1) mL/min : volume flow rate at 0 °C , 1 atm. (Compatible with SCCM.)

(Note 2) Without a protective net. Pumping speed for N₂ is 3000 L/s with a protective net.

(Note 3) The outlet flange of the turbo molecular pump should face horizontally or vertically when installing the pump horizontally and obliquely.

(Refer to 5.1.1 「Pump Mounting Direction」)

(Note 4) VG300, VG250 and ISO320B Special are also available.

4.2 Standards Fulfilled

4

Safety	EN61010-1; 2001 UL61010A-1 SEMI S2 EN1012-2; 1996
EMC	EN61326-1; 1997 + A1; 1998 + A2; 2001 class A EN61000-3-2; 1995 + A14; 2000 SEMI F47

INSTALLATION



- 5.1 Installation
 - 5.1.1 Pump Mounting Direction
 - 5.1.2 Installation of the Pump
 - 5.1.2.1 Installation of series of TMP-3203
 - 5.1.2.2 Installation of TMP-3403LMC
 - 5.1.3 Example of piping connection
 - 5.1.4 Center of gravity of the pump
- 5.2 Connection of the Pump to the Power Supply Unit
- 5.3 Interlock for Vacuum System

5.1 Installation

5.1.1 Pump Mounting Direction

5

This turbo molecular pump can be installed in vertical, the horizontal, inverted, oblique position. The outlet flange of the pump should face horizontally or vertically when installing the pump horizontally and obliquely.

When an installation direction is non-appropriate, reliability of operation may deteriorate. (Refer to Fig. 5-1)

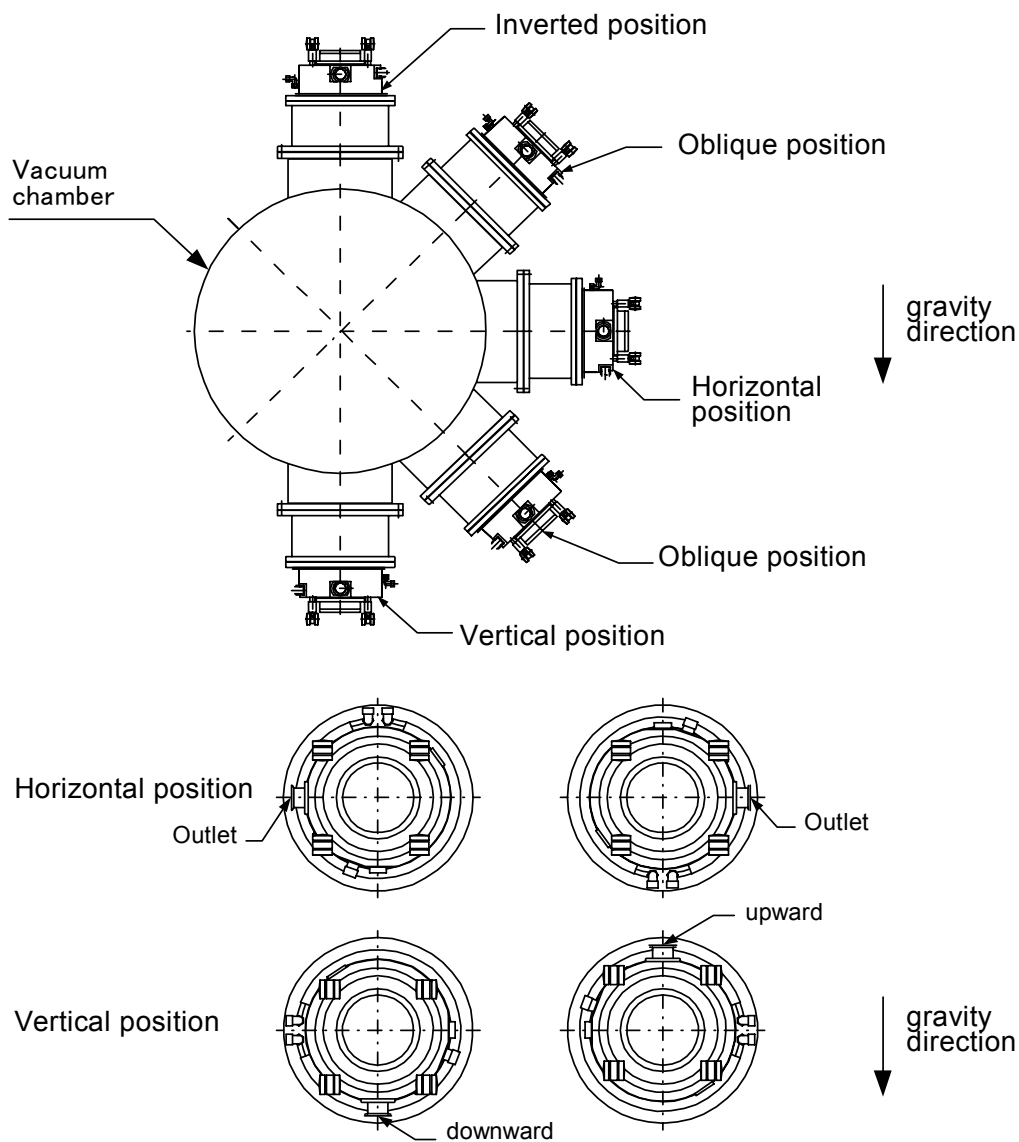

Fig. 5-1 Mounting Direction of Magnetic Levitated Turbo Molecular Pump

5.1.2 Installation of the Pump

WARNING

- Fix the pump to the device according to 5.1.2.1 and 5.1.2.2. The method to fix the pump is different depending on the pump model and the size of inlet flange of the pump.
- The device should be fixed to the floor so as not to move. The device should be designed to endure the torque 1.5 times the rapid shutdown torque to take the safety margin in preparation for an emergency accident.
- The rotor assembly of the turbo molecular pump rotates at high speed. Large rapid shutdown torque should be generated when abnormality occurs in the pump by any chance. Incidental accident will cause the pump to drop out and to make a catastrophe if the pump is fixed by insufficient method.

CAUTION

Avoid to install the pump at the following places.

- (1) Place where the pump is inevitably exposed to significant vibration and impact.
- (2) Unstable place.
- (3) Place where the pump is inevitably exposed to magnetic field and radioactive ray. The pump proper is a precision machine. Be careful not to apply abnormal vibration, shock/ impact to it during transportation.

This pump is not connected to grand. Please provide PE(Protective earth) connection to the chassis of pump in final application.

NOTICE

Before touching the pump internals and the vacuum chamber, put a pair of nylon gloves without fail. Avoid direct touch with them. Internal contamination of the vacuum chamber or the pump would cause failure of adequate vacuuming performance.

When using a hydraulic rotary pump with vibration of wide amplitude, as a backing vacuum pump, undertake proper anti-vibration measure. (As a guideline, control the vibration to 0.1 G / 50 Hz max at the outlet connection port of the turbo molecular pump.)

This pump is a precision pump. To protect the pump from torsion due to external piping load, use a bellows joint or a flexible tube to either the pump inlet or outlet, without fail.

CAUTION

The center of gravity of the pump is indicated in Fig. 5-8. Be sure that the pump does not move or fall down during installation or storage.

CAUTION

The casters provided with the pump are only auxiliary equipment for installation and storage. Use a trolley etc. for long-distance transportation.

Fix the pump in the manner shown in Fig. 5-2

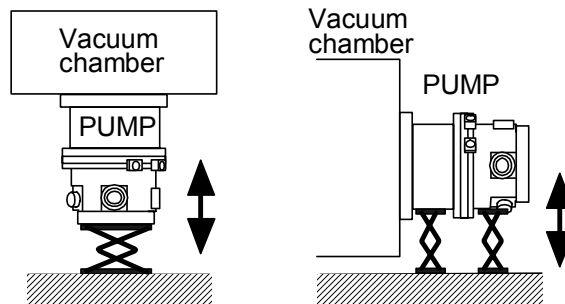

Fig. 5-2 Lifting Method

5.1.2.1 Installation of series of TMP-3203

Please fix the inlet flange of turbo molecular pump to the flange of vacuum chamber, and the base bottom of the pump to the frame of the device by the bolts of regulated grade, size, number, and tightening torque for each flange. (Refer to Table 5-1 and Table 5-2)

When you fix the pump, use all of the bolt holes of the inlet flange of the pump.

When you connect piping and the valve, etc. between the vacuum chamber and the turbo molecular pump, please fix all the bolt holes to those connection points by the method of fixing the recommendation shown in Table 5-1 and Table 5-2.

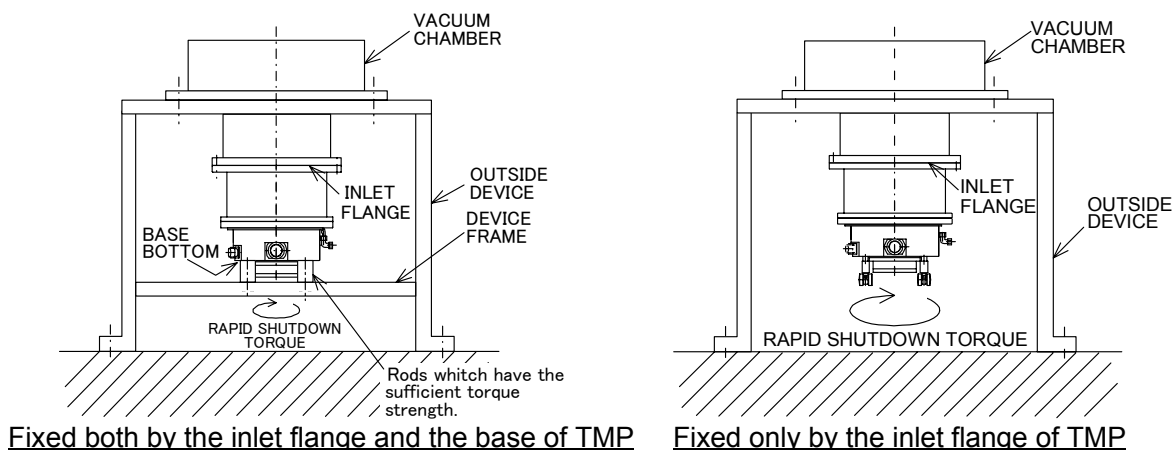

Description	Rapid Shutdown Torque
TMP-3203M/MC/LM/LMC	59,100 N · m

Fig. 5-3 Installation of series of TMP-3203

Table 5-1 The recommended fixing bolt

Fixing method		Both by the inlet flange and the base (recommended method)			
Inlet flange		VG350	VG300	ISO320B Special	VG250
Bolt Size, Quantity	Inlet flange	M12, 12PC			
	Base	M16, 8 PC			
Material		stainless steel			
Grade		A2-70 (JIS B 1054)			
Washer		Plain washer and spring lock washer	Special washer (Note) and spring lock washer		

Fixing method		Only by the inlet flange			
Inlet flange		VG350	VG300	ISO320B Special	VG250
Bolt Size,Quantity		M12, 12PC			
Material		stainless steel	SCM435 (JIS G 4105) or equivalent		
Grade		A2-70 (JIS B 1054)	12.9 (JIS B 1051)		
Washer		Plain washer and spring lock washer	Special washer (Note) and spring lock washer		

(Note) The special washers are attached to the inlet flange of TMP when shipping.

Do not remove them at the time of TMP installation.

Refer to Fig. 5-4 for the details of the bolt attaching part.

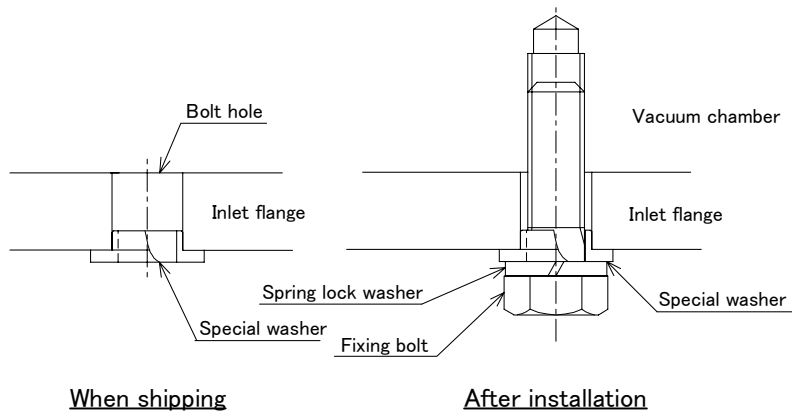

Fig. 5-4 Example of the fixing method using the special washer

Table 5-2 Tightening torque of the fixing bolt

Size of bolt	Tightening torque [N·m]
M12	16 ~ 26
M16	41 ~ 66

5.1.2.2 Installation of TMP-3403LMC

Please fix the inlet flange of turbo molecular pump to the flange of vacuum chamber, and the base bottom of the pump to the frame of the device by the bolts of regulated grade, size, number, and tightening torque for each flange. (Refer to Table 5-2 and Table 5-3)

When you fix the pump, use all of the bolt holes of the inlet flange of the pump.

When you connect piping and the valve, etc. between the vacuum chamber and the turbo molecular pump, please fix all the bolt holes to those connection points by the method of fixing the recommendation shown in Table 5-2 and Table 5-3.

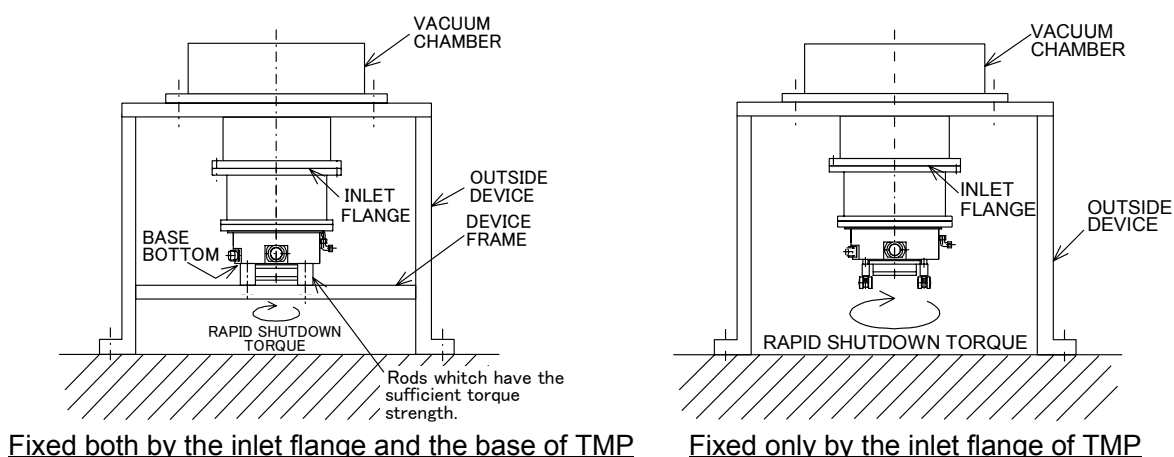

Description	Rapid Shutdown Torque
TMP-3403LMC	60,800 N · m

Fig. 5-5 Installation of TMP-3403LMC

Table 5-3 The recommended fixing bolt

Fixing method		Both by the inlet flange and the base (recommended method)			
Inlet flange		VG350	VG300	ISO320B Special	VG250
Bolt Size, Quantity	Inlet flange	M12, 12PC			
	Base	M16, 8 PC			
Material		stainless steel			
Grade		A2-70 (JIS B 1054)			
Washer		Plain washer and spring lock washer	Special washer (Note) and spring lock washer		

Fixing method		Only by the inlet flange			
Inlet flange		VG350	VG300	ISO320B Special	VG250
Bolt Size, Quantity		M12, 12PC			
Material		SCM435 (JIS G 4105) or equivalent			
Grade		12.9 (JIS B 1051)			
Washer		Plain washer and spring lock washer	Special washer (Note) and spring lock washer		

(Note) The special washers are attached to the inlet flange of TMP when shipping.

Do not remove them at the time of TMP installation.

Refer to Fig. 5-4 for the details of the bolt attaching part.

5.1.3 Example of piping connection

Connect a backing vacuum pump or its related pipe connection flange to the outlet flange of the pump. (See Fig. 5-6)

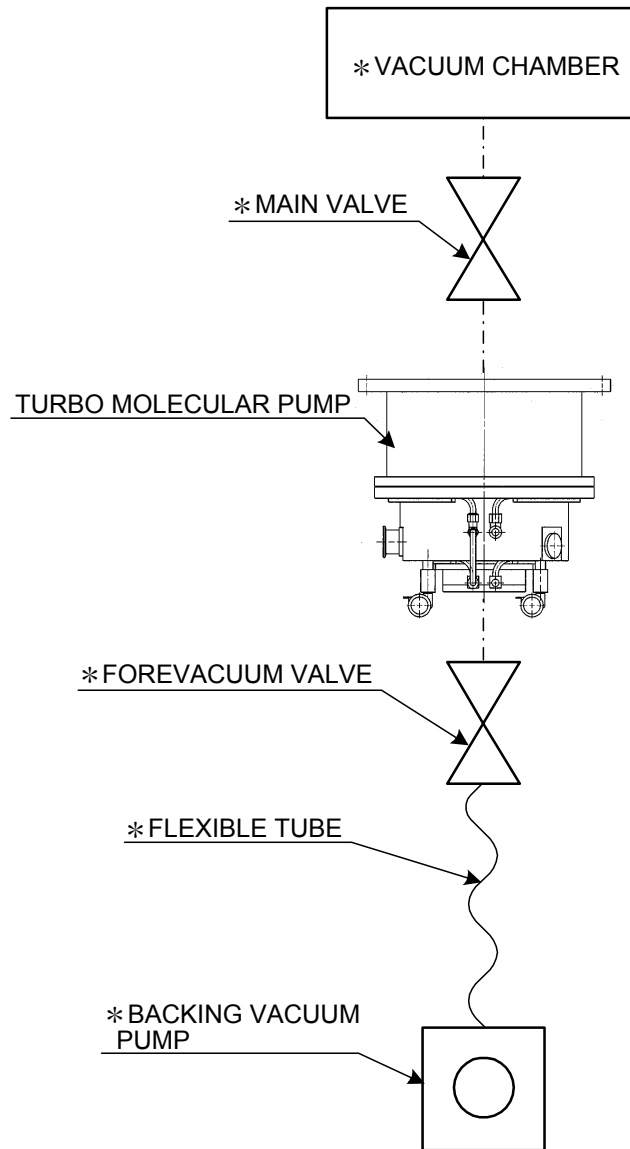

* marks are not attached to this turbo molecular pump set.

Fig. 5-6 Example of Exhaust Line

When gas purge required, connect the gas purge pipeline to the gas purge port. (For the gas purge detail, see Section 7 "Gas Purge")

After complete piping connection, check for perfect airtightness by helium leak test.

Connection of Cooling Water Line:

Connect cooling water pipes to these pumps. When connecting the cooling water pipes, screw the pipe joint while also holding the nozzle of the pump with a spanner in order to avoid deforming the cooling water pipe, as illustrated in Fig. 5-7.

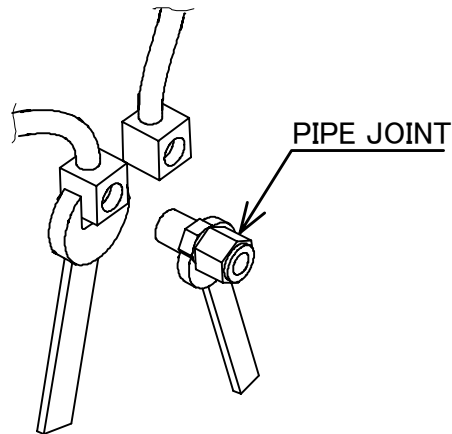
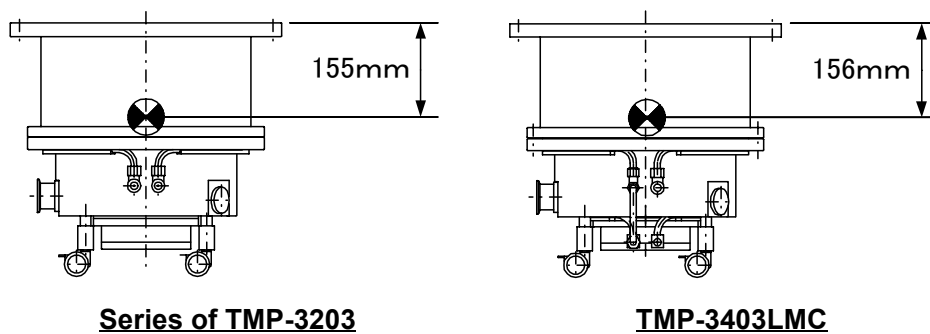

Fig. 5-7 Cooling Water Piping Connection

5.1.4 Center of gravity of the pump

The center of gravity of the pump is shown in Fig. 5-8. Fix securely to avoid moving or falling down in the event of an earthquake.



Series of TMP-3203

TMP-3403LMC

Fig. 5-8 Center of gravity of the pump

5.2 Connection of the Pump to the Power Supply Unit

CAUTION

Insert straight the control cable connector after checking its key direction.

Inserting it in oblique direction would cause damage of the connector pins. After the insertion, turn the cable connector clockwise until the rotation lock clicks.

CAUTION

Don't disconnect each cable while the pump is running. Particularly before disconnecting the control cable, Check complete shutdown of the pump by ROTATION lamp goes out and, thereafter, turn off the POWER switch.

For information regarding cable connections please refer to the Power Supply Unit Instruction Manual.

5.3 Interlock for Vacuum System

- (1) When using, as a backing vacuum pump, a vacuum pump with no check mechanism (backstream flow prevention) such as dry vacuum pump, etc., install a forevacuum valve between the turbo molecular pump and the backing vacuum pump to prevent rapid inverse flow of exhausted gas. And close the forevacuum valve before the backing vacuum pump stops. (See Fig. 5-4)
- (2) Even when "ALARM" signal is emitted, don't cut off the power supply while "ROTATION" signal is being emitted. Even when ALARM lamp lights, don't cut off the power supply while ROTATION lamp lighting.
- (3) If "ALARM" signal is emitted or ALARM lamp lights, shut down the backing vacuum pump or close the forevacuum valve immediately. Furthermore, when main valve is installed between the turbo molecular pump and the vacuum chamber, close this valve, too.
Provide a flowmeter on the downstream of cooling water line, otherwise the turbo molecular pump will shut down and otherwise set up the interlock which the pump can not start against cut off of water supply.

For more information regarding signals, please refer to the Power Supply Unit Instruction Manual.

This page is intentionally left blank

OPERATION

A decorative blue dotted line that starts horizontally from the left, then turns 90 degrees downward on the right side.

- 6.1 Outline
 - 6.1.1 Introduction
- 6.2 Start-up Preparation
 - 6.2.1 Start-up Preparation
- 6.3 Start-up
 - 6.3.1 Start-up Sequence
- 6.4 Shutting Down
- 6.5 Baking Operation

6.1 Outline

CAUTION

Neither disconnect and reconnect each cable while the pump is running.

Particularly for unplugging the control cable from the receptacle, check complete shutdown of the pump by ROTATION lamp goes out and, thereafter, turn off the POWER switch.

CAUTION

Do not turn the power off while the pump is running. The touch-down bearing may need to be replaced if the power is turned off repeatedly during operation.

If the power is turned off during rotation, power from regenerative braking will keep the rotor levitated. After slowing down, levitation stops and the rotor is supported by the touchdown bearing. Therefore, repeated touchdowns will reduce the life of the bearing.

6.1.1 Introduction

Please operate by the Power Supply Unit. For more information regarding an operation, please refer to the Power Supply Unit Instruction Manual.

6.2 Start-up Preparation

Please select "LOCAL" or "REMOTE" at the switch of the Power Supply Unit.

For more information regarding operation, please refer to the Power Supply Unit Instruction Manual.

6.2.1 Start-up Preparation

- (1) Feed the cooling water into the cooling line. (for cooling water method)
- (2) Turn on the POWER switch of the power supply unit and check if the POWER lamp lights.
And the rotor of the turbo molecular pump is levitated by the magnetic bearing.
- (3) Evacuate the turbo molecular pump by using a backing vacuum pump.
- (4) Start-up preparation is complete if the pressure in the turbo molecular pump reduces below 200 Pa.

6.3 Start-up

6.3.1 Start-up Sequence

- (1) Start-up begins when the 6.2.1 "Start-up Preparation Sequence in LOCAL Mode" is complete.
- (2) For more information regarding an operation, please refer to the Power Supply Unit Instruction Manual.

REFERENCE

A pressure check using the vacuum gauge attached to the pump inlet shows that the pressure reduces gradually after rotation starts.

6.4 Shutting Down

CAUTION

After having operated the turbo molecular pump for evacuation of corrosive gas, keep the pump internal as vacuumed even after shutdown. Inflow of water content in the air to the pump internal would cause rapid corrosion trouble of the pump internals. The pump corrosion may result in damaging the vacuum vessel interior and other units, causing pressure fluctuation by stopping the pump and dispersal of parts.

CAUTION

When reducing internal pressure of the turbo molecular pump up to around the atmospheric pressure by use of inert gas, etc., adjust the pressure reducing valve so that the internal pressure of the same pump does not exceed 20 kPa [GAUGE].

For shut-down of the turbo molecular pump, follow the sequence below.

Preparations Prior to Shutting Down Operation:

- (1) Check that process gas inflow is in complete stop. When main valve is provided between the turbo molecular pump and vacuum chamber, close the valve, too.
- (2) When purge gas is being fed into the turbo molecular pump, stop the gas feed, too.
- (3) When forevacuum valve is provided between the turbo molecular pump and backing vacuum pump, close the valve, too.

Shutting Down Sequence in LOCAL Mode:

- (1) For more information regarding an operation, please refer to the Power Supply Unit Instruction Manual.
- (2) Stop the cooling water flow. (for cooling water method)

When the turbo molecular pump is turned off after pumping a corrosive gas, maintain a vacuum inside the turbo molecular pump or purge the interior of the pump with an inert gas.

Further, in such a case when a hydraulic rotary vacuum pump is used as backing vacuum pump and there is possible reverse flow and diffusion of oil from the backing vacuum pump, return the pump internal pressure to atmospheric pressure using dry nitrogen gas, after complete shut-down of the pump [ROTATION lamp goes out], to prevent the turbo molecular pump from being contaminated with oil vapor.

For shutting down the turbo molecular pump in running at high speed with infeed of dry nitrogen gas to the pump, keep the nitrogen gas flow rate at 1500 mL/min maximum.

REFERENCE

ROTATION lamp goes out or "ROTATION" signal turns off when the pump rotational speed is 60rpm or less. Turning off the POWER switch permits the pump rotor to be supported by the touch-down bearings.

6.5 Baking Operation

CAUTION

During baking operation, cool down the turbo molecular pump in either cooling water or cooling fan.

NOTICE

Baking temperature is not allowed to exceed 120 °C .

The baking heater is installed near the inlet flange.

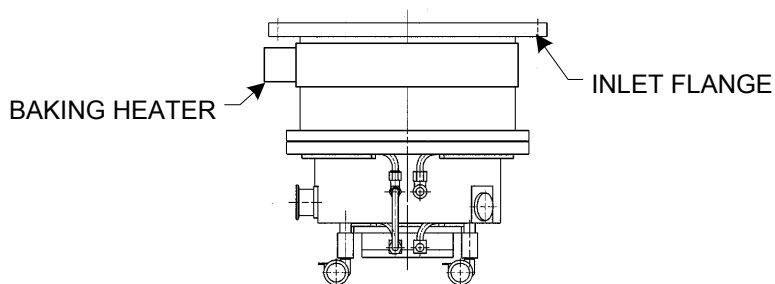
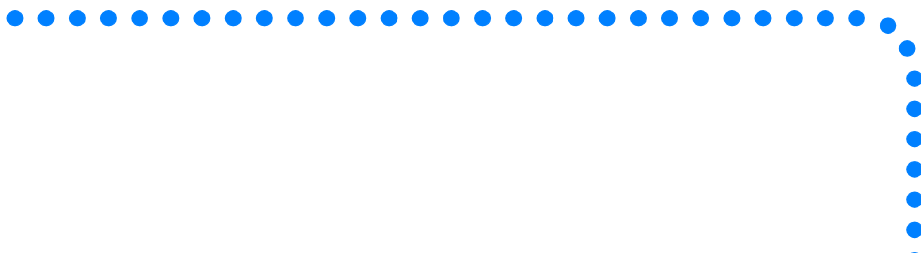

Fig. 6-1 Installation of Baking Heater

Perform baking treatment when the inlet pressure of the turbo molecular pump is 1×10^{-3} Pa or less. It is necessary to apply baking to not only the vacuum chamber but also the pump proper in order to keep an exhausting vessel at super high vacuum. However, the baking temperature is not allowed to exceed 120 °C because generally the rotor of the turbo molecular pump is made of aluminum alloy.

For baking application to the pump proper, carefully adjust the baking temperature. For the purpose, special heater is supplied with the pump system considering the temperature requirements. Use this heater for control of the baking temperature.

GAS PURGE



SECTION 7 GAS PURGE

The turbo molecular pump incorporates a gas purge port (Fig. 2-1 (2)). Gas purging is not required for ordinary evacuation. However, a purge gas flow is recommended to protect the bearings during evacuation of large quantities of corrosive gas during an etching process, for example. An inert and chemically stable non-condensing gas is most suitable for the purge gas. Nitrogen is the most popular purge gas. A purge gas flowrate between 20 and 30 mL/min is appropriate.

Please consult your shimadzu representative, during evacuation of corrosive gas.

The gas-purge adaptor is available without an orifice (recommended) or with an orifice (option).

Refer to Fig. 7-1 to check whether the gas-purge adaptor attached to the purchased pump incorporates an orifice. Connect the gas-purge adaptor correctly, according to the piping diagrams below. The diagram shows the KF10 joint, but the method of recognizing the orifice is the same for all joints.

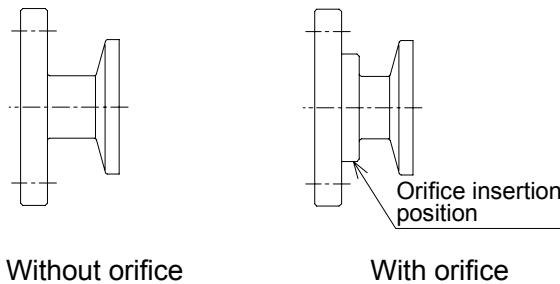

Fig. 7-1 How to Recognize if the Gas-purge Adaptor Incorporates an Orifice

Fig. 7-2 shows an example of a gas-purge piping diagram. Use a filter element size of 5 μ m, or less. Use a stop valve to start and stop the purge gas flow.

Gas supply	20 \pm 10 kPa gauge pressure (nitrogen gas)
Gas feed start	After starting backing vacuum pump; before evacuating process gas
Gas feed stop	After exhausting process gas sufficiently; before stopping backing vacuum
Type of gas	Nitrogen gas or argon gas (Purity > 99.99%)

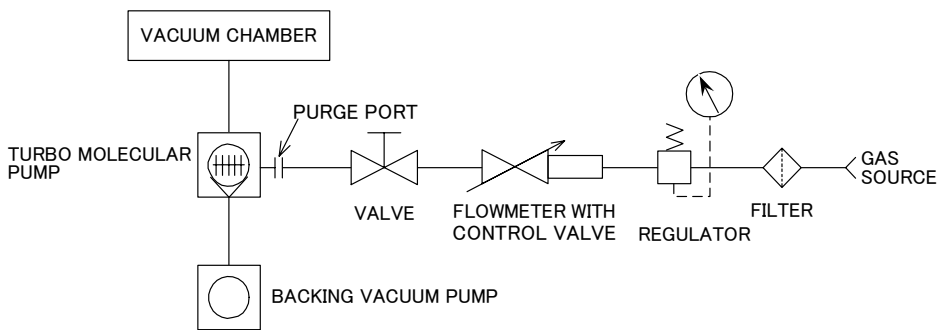

Fig. 7-2 Gas Purge Method (diameter of orifice is ϕ 0.5mm)

Joint	PART No.	Description
KF10	262-77592-19	GP ADAPTOR, 0.5 KF10
UJR 6.35	263-14770	GP ADAPTOR, 0.5 UJR
SWAGELOK ϕ 6.35	263-14771	GP ADAPTOR, 0.5 SWG
4-VCR	263-14772	GP ADAPTOR, 0.5 VCR

Table 7-1 Table of Gas-purge Ports (diameter of orifice is ϕ 0.5mm)

OPTION

A gas purge adaptor with an orifice is available as an option. The gas purge adaptor with an orifice maintains the purge gas flow between 20 and 30 mL/min if the gas-supply pressure lies within the range below. Flow control with a flowmeter is not required.

Note: Gas purge adaptors with no orifice are recommended for applications in which large amounts of reaction products are generated (e.g., metal etchers). Adaptors with an orifice will cause clogging.

Gas supply	20 ± 10 kPa gauge pressure (nitrogen gas)
Gas feed start	After starting backing vacuum pump; before evacuating process gas
Gas feed stop	After fully exhausting process gas; before stopping backing vacuum pump
Type of gas	Nitrogen gas or argon gas (Purity > 99.99%)

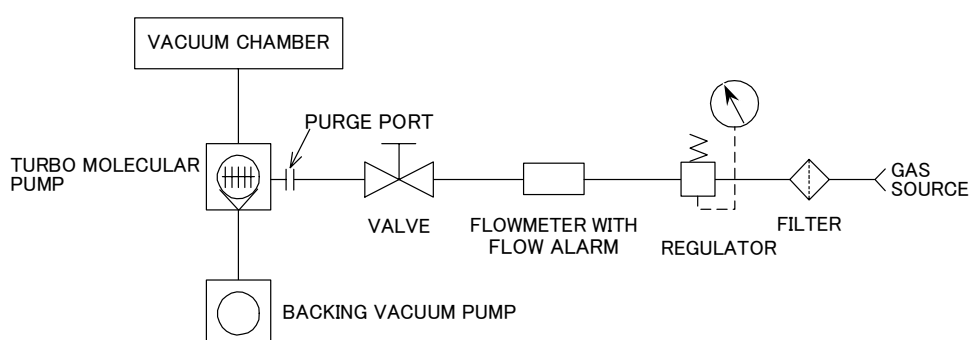

Fig. 7-3 Gas Purge Method (diameter of orifice is $\phi 0.05\text{mm}$)

Joint	PART No.	Description
KF10	262-77592-03	GP ADAPTOR, 802 KF10
UJR 6.35	262-77592-01	GP ADAPTOR, 802 UJR
SWAGELOK $\phi 6.35$	262-77592-06	GPA, SS-400 STRAIGHT
4-VCR	262-77592-14	GP ADAPTOR, 4-VCR

Table. 7-2 Table of Gas-purge Ports (diameter of orifice is $\phi 0.05\text{mm}$)

This page is intentionally left blank.

TURBO MOLECULAR PUMP RECONDITION



- 8.1 Turbo Molecular Pump Return Request
- 8.2 Turbo Molecular Pump Decontamination
- 8.3 Touch-Down Bearing Replacement
- 8.4 Check of the rotor blades

8.1 Turbo Molecular Pump Return Request

WARNING

Improper turbo molecular pump use may be hazardous to operator's health in applications not recommended or approved by Shimadzu. In the event removal of the turbo molecular pump from an application is required, full protective measures including purging of the turbo molecular pump with an inert gas and/or apparel are recommended when the turbo molecular pump has been used in applications that required the use of corrosive, reactive, stimulative, or toxic gases.

8

Annual overhaul is recommended.

Overhaul, re-manufacturing, refurbishing, or repair of the turbo molecular pump system should always be performed by Shimadzu or an approved service company. (A copy of this from is printed at the end of this manuals "Repair of Magnetic Bearing Turbo Molecular Pump")

The following precautions are required before forwarding the turbo molecular pump to Shimadzu or an approved service company for all service related requests.

- (1) The turbo molecular pump must be void of all process gases. Turbo molecular pumps that were operated in applications using special gases (doping gas, epitaxial gas, film forming gas, etching gas, etc.), likely have the process by-products, reaction-produced matter, etc. Remove them from the turbo molecular pump by repeated gas purge to the pump and fill the pump with an inert gas. The pump interior must be adequately purged with inert gas before uninstalling from the unit.
- (2) The customer is required to submit MSDS (Material Safety Data Sheet) sheets and information of all gases, materials, etc. that have been associated with the turbo molecular pump.

Shimadzu will accept and perform service only on turbo molecular pumps that have been properly prepared as stated in (1) and (2) above. Shimadzu will advise the customer of any failure precaution/prevention procedures that are appropriate to each individual turbo molecular pump service request.

Remove the pump in the manner shown in Fig. 8-1.

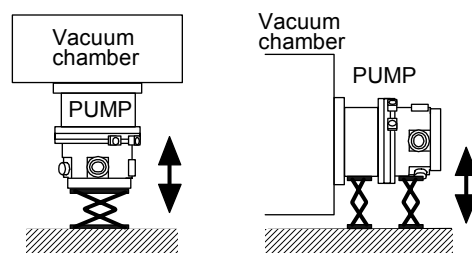

Fig. 8-1 Way to remove the pump

8.2 Turbo Molecular Pump Decontamination

All expenses incurred with the decontamination of the turbo molecular pump are the responsibility of the customer.

8.3 Touch-Down Bearing Replacement

The touch-down bearing (Fig. 3-1 (9)) is the only component of Shimadzu's turbo molecular pump that is subjected to friction and wear, normally occurring only during electrical power failure. Repeated and/or frequent rotor touch down will cause wear and bigger rotational resistance and require replacement of touch down bearings.

Shimadzu recommends replacement of the touch-down bearing by Shimadzu or an approved service company.

8

8.4 Check of the rotor blades

Rotor blades of turbo molecular pump are high-speed rotor made of aluminum alloy. It has the possibility that material strength deteriorates, specially when corrosive gas is evacuated. Regular check (Customer is liable for the cost.) by Shimadzu or a Shimadzu approved/authorized service center is suggested. (Every one year is recommended.) Shimadzu and/or the service center perform fluorescence penetrant testing of rotor blades in every overhaul task and check and suggest a rotor replacement to customers if any cracks are found out.

This page is intentionally left blank.

TROUBLESHOOTING



9.1 Vacuum Pressure Rise

9.2 Abnormal Noise and/or Vibration

9.1 Vacuum Pressure Rise

A rapid rise of vacuum pressure in the turbo molecular pump causes the internal motor of the turbo molecular pump to start braking and the ALARM lamp lights.

9.2 Abnormal Noise and/or Vibration

Should the turbo molecular pump ever generate abnormal noise and/or vibration, the turbo molecular pump operation is to be stopped immediately.

But there is possible that a race of touch-down bearing (Fig. 3-1 (9)) may make sounds for seconds when the pump internal pressure gets back to atmospheric pressure using air (or non-activity gas). This phenomena is not abnormal and make no damage to the pump, because the air whirlpool sometimes occurs and then makes the touch-down bearing rotate slightly.

Index

B

backing vacuum pump 8、14、15、24

C

CE MARKING 16

Cooling fanvi、vii

cooling water8、25

corrosive gas 41

G

gap sensor 10

gas purge 14、15、36、37

I

inlet flange8、11

O

outlet flange8、11

overhaul 40

P

port for gas purge 8

R

rapid shutdown torque 23

rotor10、11

S

SEMI F47 16

SEMI S2 16

T

touch-down bearing11、41

U

UL 16

This page is intentionally left blank.

Declaration of Conformity

SHIMADZU CORPORATION SEMICONDUCTOR EQUIPMENT DIVISION

**Address :380-1,HORIYAMASHITA,HADANO-CITY,
KANAGAWA, 259-1304, JAPAN**

as the Manufacturer

declares in sole responsibility that the following product

Product Name **Turbo Molecular Pump**

Model name , P/N

Vacuum Pump		Power Supply	
Model name	P / N	Model name	P / N
TMP-3203LM/LMC/M/MC	262-78430-xx	EI-D3203M	262-78685-xx
TMP-3403LM/LMC/M/MC	262-78503-xx	EI-D3403M	262-78694-xx

Note: -xx (P/N) means 00 to 99 or blank

referred to in this declaration conforms with following directives and standards

Machinery directive 98/37/EC amended by 98/79/EC
EN292-1:1991, EN292-2:1991+A1:1995,
EN1012-2:1996

Low Voltage directive 73/23/EEC amended by 93/68/EEC
EN61010-1:1993+A2:1995
EN61010-1:2001

EMC directive 89/336/EEC amended by 91/263/EEC, 92/31/EEC, 93/68/EEC, 93/97/EEC
EN61326:1997+A1:1998+A2:2001, class A

Note 1) This declaration becomes invalid if technical or operational modifications are introduced without manufacturer's consent.

Note 2) This declaration is valid if this product is used alone or in combination with the accessories of this product or other instruments which fulfill with the requirement of mentioned directive.

Note3) Importer/Distributor and Authorized Representative in EU is as follows:
KRATOS ANALYTICAL LTD.

Address : Whartisid, Trafford Wharf Road, Manchester M17 1GP England

Hadano, JAPAN 3 April 2003
place and date of issue



signature

Shinzo Inoue

name

Manager of Quality Assurance Dept.

Semiconductor Equipment Division

Shimadzu Corporation

Position

TMP Evaluation Form

Please fill out this evaluation form and attach to the product when you send it back to Shimadzu Service Center for repair service, etc. When you fill out this form, please describe the details as much as possible.

Evaluation items (Please check the item box, and fill out the information at the underline.)

Returned : Pump Type TMP- Product No.
 Power source Type EI- Product No.

Request : Overhaul repair others

Detail _____

Alarm name : _____ (If there is status indication lamp, light No is : _____)

System/Equipment name : _____

Date of request (date of occurrence) : _____ Expected date of treatment completion : _____

Total operation hours : _____ hrs. Date of operation start : _____ Date of delivery : _____

Please fill out the following items to make sure of worker's safty.

[Announcement of attraction material and gas]

Repair etc. may not be accepted when attraction material and gas is not removed.

• Type of attraction material : _____
 (Please fill out the etched material in etch system/equipment (GaAs substrate etc.). Please fill out the material of target in PVD system/equipment (sputter, vacuum evaporation etc.).

• Type of attraction gas

- Air, nitrogen, etc. (name :) Inert gas such as helium, etc. (name :)
 Corrosive gas (name :) Reactive/active gas (name :)
 Virulent gas (name :) Others (name :)

Attraction gas (: removed, : not removed) Influence on man's body. (YES, NO)

Treatment procedure, handling precaution, etc. for case when attraction gas is not removed.

• Is there a color changes and adhesion at inlet and outlet flange? Yes No

If there is a color changes and adhesion, we wash the TMP to keep an appropriate performance of vacuum pump.(additional charges)

Customer(Company) : Division : _____ Phone # : _____

Contact Person : _____(ext.#) _____ Authorized signature : _____

Use condition of equipment :

Gas purge : Used (ml/min) Not used (none)

For the oil type bearing :

Oil type : Standard oil Fluorine base oil(designated oil) Others()

Oil level : near upper limit medium point near lower limit less than lower limit

Others :

Dealer name : _____ Contact Person : _____ Tel _____

SHIMADZU CORPORATION

SHIMADZU CORPORATION. Internatinal Marketing Division

3. Kanda-Nishikicho 1-chome, Chiyoda-ku, Tokyo 101-8448, Japan
Phone:81(3)3219-5641 Fax:81(3)3219-5710

SHIMADZU PRECISION INSTRUMENTS, INC.

Santa Clara Office Vacuum Technology Group
2350 Walsh Avenue, Santa Clara, CA95051, U.S.A.
Phone:1(408)566-0960 Fax:1(408)566-0961

KRATOS ANALYTICAL LTD.

Wharfside, Trafford Wharf Road, Manchester M17 1GP U.K.
Phone:44(161)888-4400 Fax:44(161)888-4402

SHIMADZU (ASIA PACIFIC) PTE LTD.

16 Science Park Drive #01-01 The Pasteur Singapore Science Park, Singapore 118227,
Republic of Singapore
Phone:65-778-6280 Fax:65-779-2935

SHIMADZU INTERNATIONAL TRADING (SHANGHAI) Co., LTD.

24th Floor, Shanghai Xin-Hualian Building No.755 Huaihai Zhong Lu, Shanghai 200020
Phone:86(21)6472-8442 Fax:86(21)6472-8648