



FOR SALES AND SERVICE PLEASE CALL:

PTB SALES

T :: 626.334.0500
service@ptbsales.com
www.ptbsales.com

DATE SERVICED: _____

SOGEVAC®

SV40 BI

Single-stage, oil-sealed rotary vane pump

VIEW OUR INVENTORY

Operating instructions 300270034_002_C0

Waters Corporation

Ref.:
960331V3007



Contents

	Page
Important Safety Information	3
1 Description	5
1.1 Principle of operation	5
1.2 Technical characteristics	6
1.3 Accessories	8
1.4 Lubricants	8
2 Transport and Storing	9
2.1 Transport and packaging	9
2.2 Mounting orientation	9
2.3 Storing	9
3 Installation	10
3.1 Setting up	10
3.2 Electrical connections	11
4 Operation	13
4.1 Operation	13
4.2 Working in cycles in / out	14
4.3 Switching off / Shutdown	14
5 Maintenance	15
5.1 Safety Information	15
5.2 Maintenance Intervals	15
5.3 Leybold Service	16
5.4 Maintenance Work	16
6 Troubleshooting	18
7 Spare parts	20
EU Declaration of Conformity	24

Safety Information

Important Safety Information

Indicates procedures that must be strictly observed to prevent hazards to persons.

Indicates procedures that must be strictly observed to prevent damage to, or destruction of the product.

Emphasizes additional application information and other useful information provided within these Operating Instructions.

The Leybold Sogevac® SV40 BI has been designed for safe and efficient operation when used properly and in accordance with these Operating Instructions. It is the responsibility of the user to carefully read and strictly observe all safety precautions described in this section and throughout the Operating Instructions. The Sogevac® SV40 BI **must only be operated indoor in the proper condition and under the conditions described in the Operating Instructions**. If not, the protection provided by the equipment may be impaired. It must be operated and maintained by trained personnel only. Consult local, state, and national agencies regarding specific requirements and regulations. Address any further safety, operation and/or maintenance questions to our nearest office.

Failure to observe the following precautions could result in serious personal injury!

Sogevac® pumps are not designed:

- for pumping of dusty, aggressive, corrosive, flammable or explosive gases or gases mixtures,
- for pumping of oxygen or other highly reactive gases with a greater concentration than atmospheric concentration (>20%),
- for working in flammable, explosive or dusty environment.

For all these cases, special materials must be used. In case of doubt, please contact Leybold.

See also the limits of use indicated in the CE declaration of conformity.

Never expose part of the body to the vacuum. There is a danger of injury. Never operate the pump with an open and thus accessible inlet. Vacuum connections as well as oil filling and oil draining openings must not be open during operation of the pump.

When operating pump is hot and some surfaces could reach a temperature higher than 80 °C (176 °F). There is a risk of burn by touching.

Depending on the process involved, dangerous substances and oil may escape from the pump. Take the necessary safety precautions !

Disconnect the unit from the power supply before starting any work.

Pump must not be operated above 2000 m sea level.

These installation and operating instructions are valid for Waters use of the

Warning

Caution

Note

Warning



Warning



Safety Information

Warning



Sogevac® pumps, model SV40 BI.

The Sogevac® vacuum pumps have been manufactured according to the latest technical standards and safety regulations. If not installed properly or not used as directed, dangerous situations or damages could occur.

It is mandatory that these operating instructions be read and understood prior to vacuum pump installation and start-up.

The pump complies to the standard EN 61010-1-2004.

Warning



Take appropriate precautions to insure that the pump cannot start.

If the pump has pumped hazardous gases it will be absolutely necessary to determine the nature of the hazard involved and take the appropriate safety precautions.

Observe all safety regulations!

Take adequate safety precautions prior to opening the intake or exhaust port.

Caution

Failure to observe the following precautions could result in damage to the equipment!

Liquid and solid particles must not enter the pump. Install the adequate filters, separators and/or condensers. In case of doubt consult Leybold.

The intake line of the pump must never be connected to a device with over atmospheric pressure. Design the exhaust line so that no pressure higher than 1,15 bar abs. (0,15 bar rel.) can occur.

Operating of the pump without oil or operating with incorrect direction of rotation can destroy the pump.

Never use discarded seals. Always assemble using new seals.

Note

Respect the instructions concerning environment protection when discarding used oil or exhaust filters!

The pump must be packaged in such a way that it will not be damaged during shipping, and so that no harmful substances can escape from the package.

We reserve the right to alter the design or any data given in these Operating Instructions. The illustrations are not binding.

Caution



Caution : hot surface ! In normal operation, the pump surface temperature can exceed 80°C. There is a risk of burning. Switch off the pump and let it cool down before any intervention or take appropriate precautions.

1 Description

Sogevac® pumps are designed for pumping of inert gases in the range of rough vacuum, between atmospheric pressure and ultimate pressure of the pump.

When removing condensable vapors, periodic opening of the gas ballast valve is required.

1.1 Principle of operation

The Sogevac® pumps SV40 BI are single-stage oil-sealed rotary vane vacuum pumps.

The rotor, having three slots in which the vanes are sliding, is eccentrically installed in a pump cylinder (stator).

The vanes separate the interior space into 3 chambers. The volume of these chambers varies with the rotation of the rotor.

The gas sucked into the inlet chamber is compressed and then pushed out at the exhaust valve.

The oil injected in the inlet chamber guarantees the air-tightness, the lubrication and cooling of the pump. It is dragged off by the compressed gases and roughly separated by gravity when entering in the oil sump. A fine separation is then operated in the exhaust filter. An internal transfer pushes the collected oil back into the vacuum generator, the transfer is operated by a float valve to avoid atmospheric air coming from the oil casing to the inlet of the pump when no oil is present in the recovery system.

The oil circulation functions by differential pressures.

The pumps are equipped with a gas ballast valve for pumping condensable vapors.

The anti suckback valve at the inlet flange avoids oil coming back into the inlet line when the pump is stopped. This is valid for working pressures below 100 mbar and under the condition that the valve is kept clean and in good condition. The anti suck

back valve is not a safety valve. If oil back flowing is to be avoided by all means, it is necessary to mount a separate safety valve on the pump inlet.

Description

1.2 Technical characteristics

SV40 B

Technical data		50 Hz	60 Hz
Nominal pumping speed	m ³ /h	42	50
Pumping speed (according to PNEUROP)	m ³ /h at 2 mbar	> 35	> 45
Ultimate partial pressure without gas ballast	mbar	≤ 0,25	≤ 0,25
Ultimate total pressure with small gas ballast	mbar	≤ 0,8	≤ 0,8
Water vapor tolerance: ■ with small gas ballast	mbar	10	10
Water vapor tolerable load: ■ with small gas ballast	kg.h ⁻¹	0,28	0,34
Noise level (according to DIN 46 635)	dB (A)	60 (1φ)	63 (1φ)
Motor power - Rated rotational speed	kW - min ⁻¹	1,6-1500 (1φ)	1,9-1800 (1φ)
Mains voltage (+/- 10 %) AC ~	V	200	240
Protection - Insulation		IP 55 - F	IP 55 - F
Leak rate	mbar.l.s ⁻¹	<1 x 10 ⁻³	<1 x 10 ⁻³
Oil type / Capacity	l		LV0110 / 2x1
Intake connection			25KF
Exhaust connection			Barbed fitting 0.5" ID tubing

See pump nameplate for further data.

Description

SV40 BI

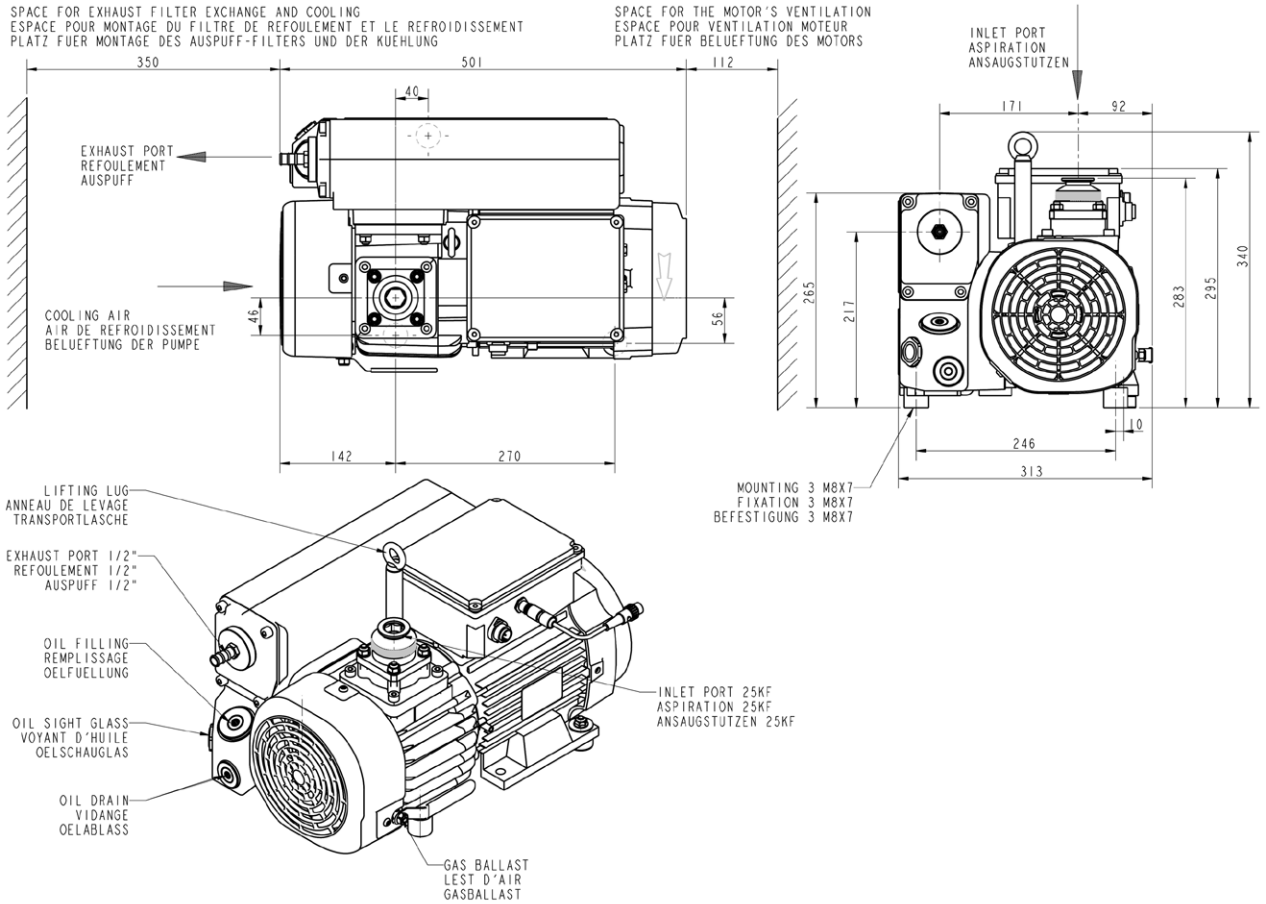

Pumping speeds curves SV40 BI

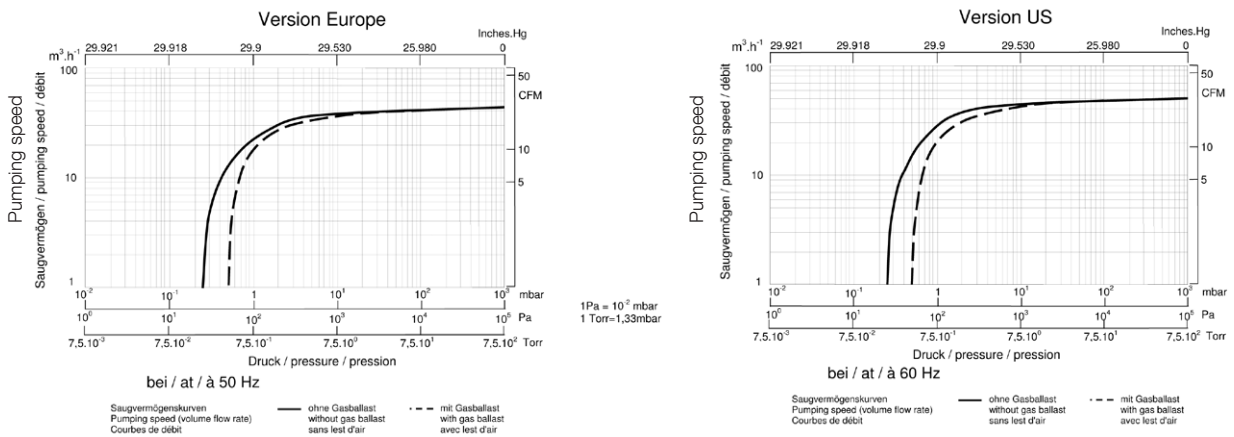

fig. 1

Description

1.3 Accessories

SV40 BI

Specification	Cat. Nr.
Oil level switch	711 19 110
Temperature switch	9 714 32 820
Exhaust filter over pressure switch	9 714 25 890
Exhaust filter over pressure manometer	951 94
Oil drain tap	711 30 114

1.4 Lubricants

The Sogevac® SV40 BI pump should be run with a synthetic oil for vacuum pumps with low viscosity according to ISO category VG32. The Leybold oil LV0110 corresponds to these prescriptions.

LV0110 oil:	Conditioning	Reference
	1 l	9 714 50 502

Use only oil LV0110.

Transport and storing

2 Transport and Storing

2.1 Transport and packaging

Sogevac® vacuum pumps pass a rigorous operating test in our factory and are packaged to avoid transport damages.

Please check packaging on delivery for transport damages.

The outer package bears a shock indicator, turning red at 50 g. Should the shock indicator have reacted, a transportation damage may have occurred and the freight forwarder must be advised.

Packing materials should be disposed off according to environmental laws or re-cycled. These operating instructions are part of the consignment.

The connection ports are blanked off by plastic protective caps or self-adhesives. Take these caps or self-adhesives away before turning on the pump.

The necessary oil is supplied in cans beside the pump.

2.2 Mounting orientation

See required space on drawings in paragraph 1.2.

Pumps which have been filled with oil must only be moved in the upright position (horizontally). Otherwise oil may escape. The angle of slope may not be over 10° max. Avoid any other orientations while moving the pump.

Only use the lifting lugs which are provided on the pump to lift the pump with the specified lifting devices.

Make sure that these have been installed safety. Use suitable lifting equipment. Make sure that all safety regulations are observed.

2.3 Storing

Before stocking the pump for a long time put it back in its original condition (blank off inlet and exhaust ports with the shipping seals, drain the oil) and store the pump in a dry place at room temperature.

Storage temperature: - 15°C to + 50°C.

Until the pump is put back in to service again, the pump should be stored in a dry place, preferably at room temperature (20 °C - 168 °F). Before taking the pump out of service, it should be properly disconnected from the vacuum system, purged with dry nitrogen and the oil should be exchanged too. The gas ballast must be closed and if the pump is to be shelved for a longer period of time it should be sealed in a plastic bag together with a desiccant (Silicagel).

If the pump has been shelved for over one year, standard maintenance must be done and the oil must be exchanged too before the pump is put in to service once more.

We recommend that you contact the service from Leybold.

Caution

Installation

Warning



3 Installation

It is essential to observe the following instructions step by step to ensure safe start-up. Start-up may only be conducted by trained specialists.

The standard pump is not suitable for installation in explosion hazard ATEX areas. Please contact us, if you are planning such an application. Before installing the pump you must reliably disconnect it from the electrical power supply and prevent the pump from running up inadvertently.

Observe all safety regulations.

3.1 Setting up

The pump must be set up or mounted horizontally on a flat surface. Special mounting is not required.

The pump must be levelled within a tolerance of ± 2 degrees.

The following ambient operating environment must be observed:

- Pollution degree CSA 2
- Ambient temperature: 12 °C to 40 °C (54 °F to 104 °F),
- Ambient pressure = Atmospheric pressure.
- Rel. humidity ≤ 95 % without condensation

In order to avoid over-heating of the pump, an undisturbed fresh airflow to the pump is necessary.

Additional warning note : consider changes in ambient temperatures that might occur when air conditioning is turned down, such as nights and week-ends.

Caution

Inlet connection

See safety instructions page 3.

- The inlet flange can be connected with a vacuum-tight flexible hose and/or pipe.
- The pipes should cause no stresses on the pump's flanges. If necessary, compensators must be open.
- Restriction of the pipes must be avoided in order not to decrease the pumping speed of the pump. The nominal diameter of the pipes has to be at least the same as the diameter of pump's inlet flange.
- When removing condensable vapors, a gas ballast valve must be open periodically to avoid solvent build up in the oil.
- Additional warning note: additional air flow may be needed during ballast, as this increases pump temperature.
- The inlet pressure must not be above atm. pressure.

See also indications on the CSA pump nameplate.

Warning



Connection to exhaust side

■ No valve or restricting devices should be installed in the exhaust line of the pump. If an exhaust line is installed, it must at least have the same diameter as the exhaust flange. It should be installed in a manner so that no condensate can enter the pump (siphon, slope).

The maximum exhaust pressure must neither exceed 1.15 bar absolute (0.15 bar relative), nor fall under atmosphere pressure minus 15 mbar.

Warning



3.2 Electrical connections

Ensure that incoming power to the pump is off before wiring the motor or altering the wiring.

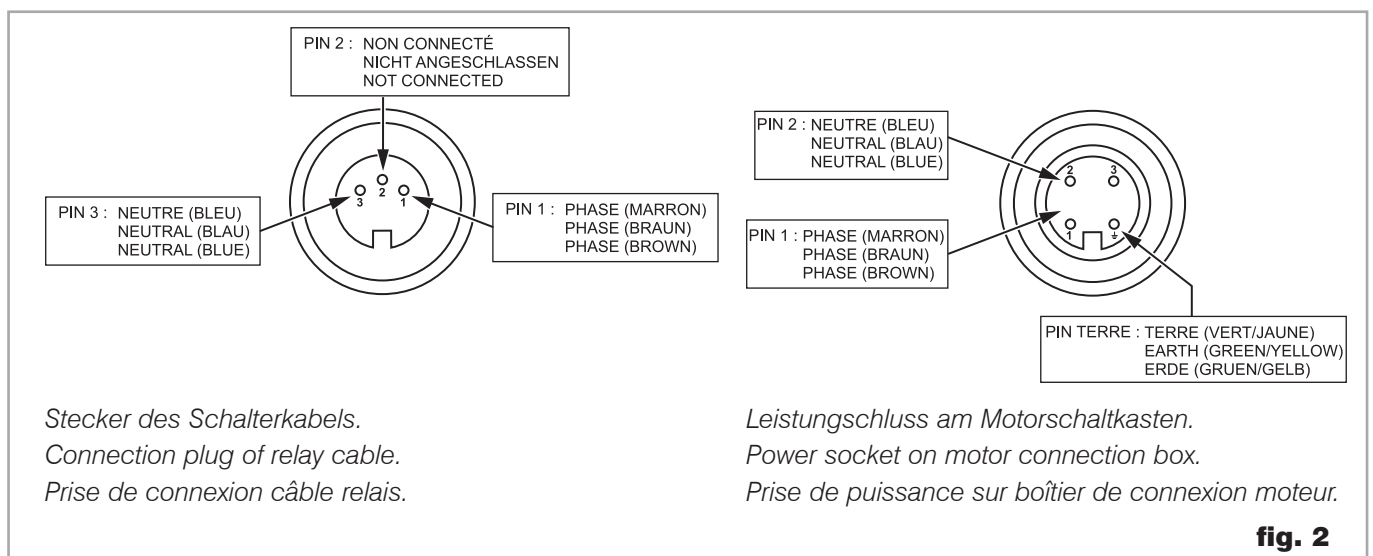

The electrical installation may only be conducted by a specialist. Local regulations have to be followed.

Electrical connection work must only be carried out by a qualified electrician in accordance with the applicable safety rules, see IEC 60204-1.

Warning



The motor must be protected by magnetic thermo breaker type GV2 ME14 adjustable from 6 to 10 A from Schneider Electric or similar.

For an operation at 50 Hz the breaker must be set at 8.5 A. For an operation at 60 Hz the breaker must be set at 10 A.

Therefore, even if the pump is not operating, live voltage is present in the motor connection box !

Voltage and frequency mentioned on the pump nameplate must agree with the supply voltage.

Installation

The motor connection box integrates an ON/OFF 24 VDC relay. The pump operation is commanded with a 24 VDC signal lead through a dedicated cable.

The final end product must provide a 24 VDC signal (protected by a 3 A fuse) for the remote control power relay coil. This 24 VDC signal shall be generated by a power supply complying to IEC 61010-1: 2001 (2nd Edition) double or reinforced insulation requirements (equivalent standards requirements like IEC60950-1) are acceptable.

Caution

3.3 Oil filling

For SV40 BI, the necessary oil is supplied in cans beside the pump.

To fill in the oil, unscrew the oil fill plug (58) and fill in until the oil level reaches the "MAX" mark beside the oil sight glass. Typically the whole 1 l oil can is used

4 Operation

4.1 Operation

To avoid overloading the motor, do not start the pump more than 6 times within one hour. If more than 6 starts per hour are necessary keep the pump running and mount a valve which opens and closes into the intake line.

Take note of warning labels on the pump.

Warning



Pumping of non-condensable gases

If the pump system contains mainly non condensable gases, the pumps should be operated without gas ballast.

If the composition of the gases to be pumped is not known and if condensation in the pump cannot be ruled out, run the pump with gas ballast valve open in accordance with section below.

Pumping of condensable gases and vapors

With the gas ballast valve open and at operating temperature, the Sogevac® pumps can pump pure water vapor up to the values indicated in the Technical Data.

The gas ballast valve is open by a hand lever. The running noise of the pump is slightly louder if the gas ballast valve is open. Before pumping vapors ensure that the pump has warmed up for approx. 30 min. with closed intake line and with open gas ballast valve.

Don't open the pump to condensable vapors until it has warmed to operating temperature (approximately); pumping process gas with a cold pump results in vapors condensing in the oil.

For processes with a high proportion of condensable vapors, the intake line should be open only slowly after reaching the operating temperature.

One sign of condensation of vapors in the pump is a rise of the oil level during operation of the pump.

When vapors are pumped, the pump must not be switched off immediately after completion of the process because the condensate dissolved in the pump oil may cause changes or corrosion. To prevent this, the pump must continue to operate with open gas ballast valve and closed intake port until the oil is free of condensate. We recommend operating the pump in this mode for at least 30 min. after completion of the process.

Daily ballasting is recommended when continuously pumping larger volumes of condensable vapors.

In cycle operation, the pump should not be switched off between the cycles but should continue to run with gas ballast valve open and intake port closed (if possible via a valve). Power consumption is minimal when the pump is operating at ultimate pressure.

Once all vapors have been pumped off from a process (e. g. during drying), the gas ballast valve can be closed in order to improve the ultimate pressure.

Caution

Caution

Note

4.2 Working in cycles in / out

We recommend strongly to limit starting of the pump to 5 or 6 per hour. If the process need it, we recommend utilization of a pneumatic or electromagnetic valve and to let the pump run continuously.

4.3 Switching off / Shutdown

The intake port of the Sogevac® pumps contains an anti-suckback valve which closes the intake port when the pump is switched off, thus maintaining the vacuum in the connected apparatus and preventing oil from being sucked back into the apparatus. The valve's functioning is not impaired by gas ballast operation.

If the pump has to be shutdown, drain the oil flush out the pump with fresh oil and fill in the required amount of clean oil (see § 5.4). Close the connection ports. Special preservation or flushing oils do not need to be used.

Caution

When the pump has been switched off due to over heating, initiated by the motor or its temperature detector, the pump must be cooled down to the ambient temperature, and must only be switched on again manually after having eliminated the cause.

In order to prevent the pump from running up unexpectedly after a mains power failure, the pump must be integrated into the control system in such a way that the pump can only be started by a manually operated switch. This applies equally to emergency cut-off switches.

In case of switching processes in connection with a pump which has warmed up under operation conditions, the pump must then not be directly switched on again.

5 Maintenance

5.1 Safety Information

Observe all safety regulations.

All work must be done by suitably trained personnel. Maintenance or repairs carried out incorrectly will affect the life and performance of the pump and may cause problems when filling warranty claims.

Never mount used seals; always mount new seals.

5.2 Maintenance Intervals

The intervals stated in the maintenance schedule are approximate values for normal pump operation. Unfavourable ambient conditions and/or aggressive media may significantly reduce the maintenance intervals.

Maintenance job	Frequency	Section
Check the oil level	Daily	A
1st oil change	After one year of operation	B
Subsequent oil changes	After one year of operation	B
Exhaust filter replacement	Annually	C
Gas ballast valve	Monthly checking	D
Inlet flange sifter cleaning	Annually	E
Anti-suck back valve checking	Annually	F
Fan cover cleaning	Annually	G
Electrical connection checking (only by a specialist)	Annually	

In order to simplify the maintenance work we recommend to combine several jobs.

Warning



Caution

Maintenance

Contamination

5.3 Leybold Service

Whenever you send us in equipment, indicate whether the equipment is contaminated or is free of substances which could pose a health hazard.

If it is contaminated, specify exactly which substances are involved. You must use the form we have prepared for this purpose.

Formulaire

A copy of the form has been reproduced at the end of these Operating Instructions: "Declaration of Contamination for Compressors, Vacuum Pumps and Components". Another suitable form is available from www.leybold.com Documentation → Download Documents.

Attach the form to the equipment or enclose it with the equipment.

This statement detailing the type of contamination is required to satisfy legal requirements and for the protection of our employees.

We must return to the sender any equipment which is not accompanied by a contamination statement.

The pump must be packaged in such a way that it will not be damaged during shipping, and so that no harmful substances can escape from the package.

When disposing of used oil, please observe the relevant environmental regulations.

Caution

5.4 Maintenance Work

Checking the oil

A. Oil level

The oil level shall be checked at least once a day and must be, while the pump is in operation, close to the MAX marks. Should the oil level be below the MIN mark switch off the pump, check it (see chapter 4) and add the required amount of oil.

Oil level may drop when pump is operating due to oil distribution in the pump.

B. Oil Change

Oil must be changed after the first year of service. Further oil changes must be done annually. If there is considerable pollution, it could be necessary to change the oil more frequently.

Oil changing must be done with a switched off and still warm pump. Open the oil drain plug and let the used oil run out into an appropriate container. Refasten the oil drain plug when oil runs slowly. Switch ON the pump briefly (5 sec. max.) and switch OFF immediately. Reopen the oil drain plug and drain the rest of the oil.

Additional warning note: more frequent oil changes may be necessary if the ambient temperature is above 30 °C.

Before refastening the oil drain plug, inspect the o-ring and verify that it is free of particulate and is seated properly. Replace if necessary.

The pump should be "flushed" if there is considerable pollution.

To flush the pump, for clean oil up to the minimum level, let the pump run for a few minutes and drain the oil. Install a full charge of oil, 1 liter.

C. Replacing the exhaust filters

Oil mist escaping from the exhaust during operation indicates that the filter is probably clogged. Increased energy intake by the motor could also be the result of a soiled exhaust filter. Open the exhaust hood, take out the filter and replace it. Also check the gasket of the exhaust flange and change it if necessary.

D. Gas ballast valve cleaning

To clean the gas ballast valve, disassemble the fan cover and the fan. Unscrew the lateral pressure screw, remove the plug and the gas ballast valve by using an appropriate M10 screw screwed in the valve by pulling on the screw.

Clean the membrane, the seat and the RILSAN tube.

Reassemble in the reverse sequence.

E. Inlet flange sifter cleaning

To clean the inlet flange sifter, disconnect the inlet flange and clean the sifter with blast air or an appropriate solvent.

F. Anti-suck back valve checking

The anti-suck back valve should be checked at the same time as the inlet flange sifter and if dirty, be cleaned with an appropriate solvent.

Also check, if there is no damage on the sealing part of the valve.

G. Fan cover cleaning

Soiling of the fan cover may lead to overheating of the motor and the pump.

Put off the cover and clean it with blast air.

Before starting the pump again, be sure that the cover has been reassembled.

H. Checking the float valve

When replacing the exhaust filter, check the cleanliness and the proper operation of the float valve. After having disassembled the exhaust flange and oil casing, remove screw (pos. 57d), pull on the float valve (pos. 57), clean the nozzle and check that the float itself oscillates free around its axle and that the valve is tight. Clean the float chamber of the oil casing. Reassemble in the reverse sequence.

Troubleshooting

6 Troubleshooting

Fault	Possible cause	Remedy	Reference section *
Pump does not start.	Pump is connected incorrectly.	Connect the pump correctly.	3.3
	Motor protection switch incorrectly set.	Set motor protection switch properly.	3.3
	Operating voltage does not match motor.	Replace the motor.	
	Motor is malfunctioning.	Replace the motor.	
	Oil temperature is below 12 °C (54 °F).	Heat the pump and pump oil or use different oil.	1.4
	Oil is too viscous.	Use appropriate oil grade.	5.4-B
	Exhaust filter / exhaust line is clogged.	Replace the filter or clean the exhaust line.	5.4-D
Pump does not reach ultimate pressure.	External leak	Repair the pump.	
	Float valve does not close.	Repair the valve.	5.4-H
	Anti-suckback valve is malfunctioning.	Repair the valve.	5.4-F
	Inadequate lubrication due to:		
	■ unsuitable or contaminated oil,	Change the oil (degas it, if necessary).	5.4-C
	■ clogged oil filter,	Replace the oil filter.	5.4-C
	■ clogged oil lines.	Clean the oil casing.	
Vacuum lines are dirty.	Clean vacuum lines.		
Pump is too small.	Check the process date; replace the pump, if necessary.		
Pumping speed is too low.	Dirt trap in the intake port is clogged.	Clean the dirt trap ; Precaution : install a dust filter in intake line.	5.4-E/1.2/3.2
	Exhaust filter is clogged.	Install new filter elements.	5.4-D
	Connecting lines are too narrow or too long.	Use adequately wide and short connecting lines.	3.2
	Anti-suckback valve is hard to open.	Check spring free length.	
After switching off pump under vacuum, pressure in system rises too fast.	System has a leak.	Check the system.	
	Anti-suckback is malfunctioning.	Repair the valve.	5.4-F
Pump gets too hot	Cooling air supply is obstructed.	Set pump up correctly.	3.1
	Cooler is dirty.	Clean the cooler.	
	Ambient temperature is too high.	Set pump up correctly.	3.1
	Process gas is too hot.	Change the process.	
	Oil level is too low.	Add oil to reach the correct oil level.	5.4-C
	Oil is unsuitable.	Change the oil.	5.4-C
	Oil cycle is obstructed.	Clean or repair the oil lines.	
	Exhaust filter / exhaust line is obstructed.	Replace the exhaust filter, clean the exhaust line.	5.4-D
Pump module is no longer usable.	Replace the pump module.	5.4-K	

Troubleshooting

Fault	Possible cause	Remedy	Reference section *
Oil in intake line or in vacuum vessel.	Oil comes from the vacuum system.	Check the vacuum system.	
	Anti-suckback valve is obstructed.	Clean or repair the valve.	5.4-F
	Sealing surfaces of anti-suckback valve are damaged or dirty.	Clean or repair the intake port and valve.	5.4-F
Pump's oil consumption too high, oil mist at exhaust.	Oil level is too high.	Drain the excess oil.	5.4-B
	Exhaust filters are clogged or damaged.	Replace the filters.	5.4-C
	Nozzle of float valve is clogged.	Check the valve, clean the nozzle.	5.4
Oil is turbid.	Oil level is too high.	Drain the excess oil.	5.4-B
	Condensation.	Degas the oil or change the oil and clean the pump. Precaution : open the gas ballast valve or insert a condensate trap.	4.1/5.4-B
		Clean the gas ballast intake filter.	5.4-G
Pump is excessively noisy.	Oil level is very low (oil is no longer visible).	Add oil.	5.4-B
	Oil filter is clogged.	Change the oil and filter.	5.4-B
	Large vacuum leak in system.	Repair vacuum leak. Contact Leybold.	

* Reference section : This column refers to the section in the Operating Instructions that contains the applicable repair information.

Never mount used seals. Always mount new seals.

Spare parts

7 Spare parts

To guarantee safe operation of the Leybold pump, only original spare parts and accessories should be used. When ordering spare parts and accessories, always state pump type and serial number. You can find part numbers in the spare parts list.

Consumables and main spare parts kits for Sogevac® pumps are usually available on stock at Leybold's service centers. The list of these parts is given hereafter and in the spare parts table where the contents of each kit is detailed.

- Exhaust demisters
- Oil
- Service kit
- Set of seals
- Repair kit

We recommend to use these kits which have been defined to allow an optimal maintenance or repair. Individual spare parts may need longer delivery time.

Spare parts

SV40 BI

960331V3007

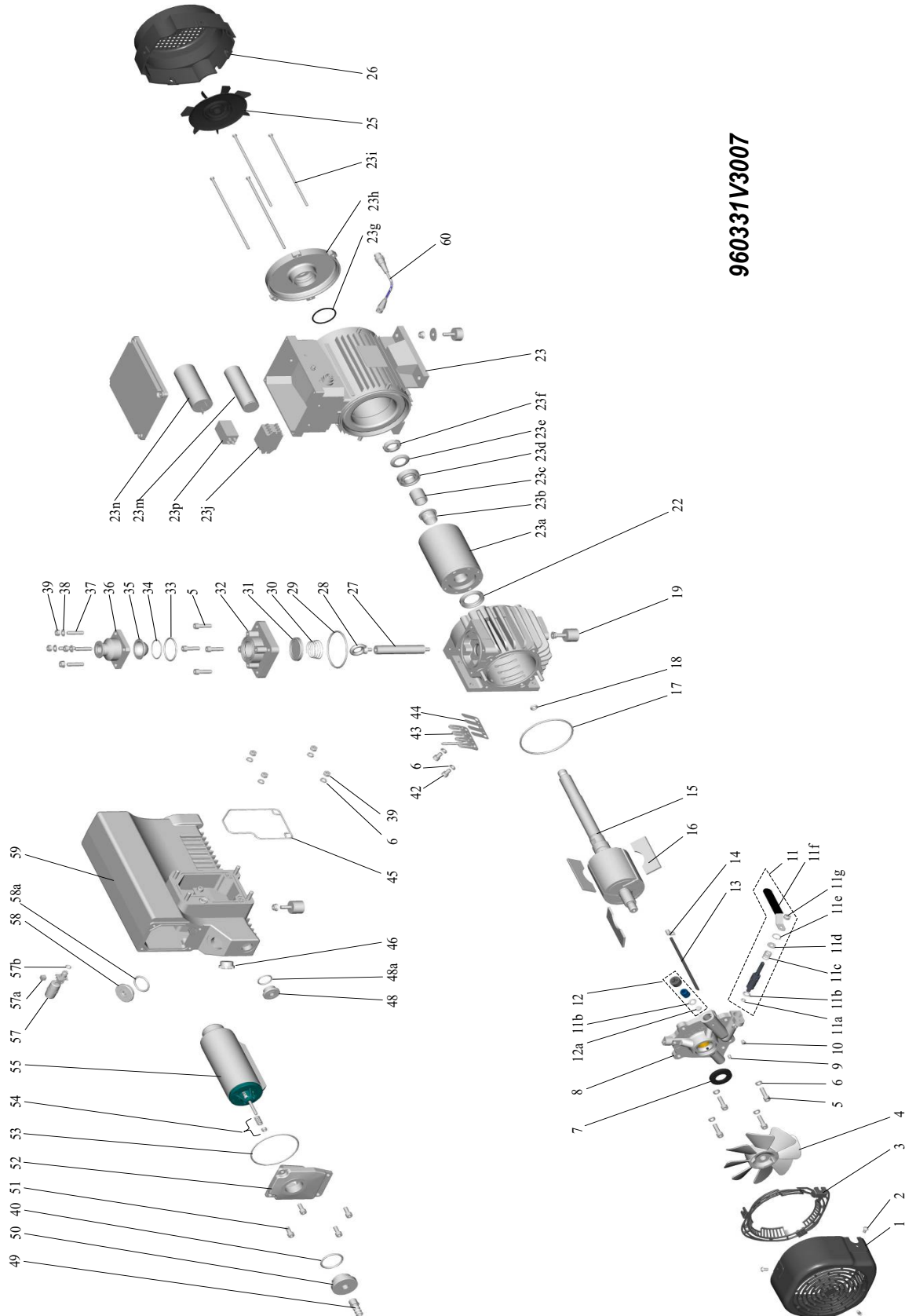

fig. 3

Spare parts

Pos.	Stück k. Qty Qté	BENENNUNG	SPECIFICATION	DESIGNATION	Abmessungen (mm) Dimensions (mm) Dimensions (mm)	Bestell-Nr Ref. No, N° de réf	Bemerkungen Notes Remarques	971452150	971443150	971454600	971427660
1	1	GEHÄUSEDECKEL	MODULE COVER	CAPOT POMPE		971424850					
2	3	SCHRAUBE	SCREW	VIS BOMBEE PLATE	HC M6X12						
3	1	SCHUTZBLECH	PROTECTIVE COVER	GRILLE PROTECTION POMPE		971424860					
4	1	LUEFTER	COOLING FAN	HELICE DE REFROIDISSEMENT		971424870					
5	8	SCHRAUBE	SCREW	VIS	CHC M8 X 30 Q8.8					●	
6	10	UNTERLEGSCHLEIBE	WASHER	RONDELLE	W8					●	
7	1	RADIAL-DICHTRING	RADIAL SHAFT SEAL	JOINT A LEVRE	D25/D47X6	71421000		●		●	
8	1	LAGERDECKEL MIT GB	END PLATE WITH GB	FLASQUE BAGUE AVEC L.A		971454590	Incl.7,11,12,13,14,17,18			●	
9	1	SCHRAUBE	SCREW	VIS BOUT CONIQUE	HC M6X10 Q8.8						
10	1	SCHRAUBE	SCREW	VIS INDEXAGE	M6	971424710					
11	1	GASBALLASTVENTIL6WELLE	GAS BALLAST VALVE SHAFT	COMMANDE LEST D AIR		971454560	Incl.10,11a,b,c,d,e,f,g				
11a	1	O-RING	O-RING	JOINT TOR	D4.42			●			
11b	2	O-RING	O-RING	JOINT TOR	D10.77			●			
11c	1	FEDER	SPRING	RESSORT							
11d	1	UNTERLEGSCHLEIBE	WASHER	RONDELLE	M8						
11e	1	SICHERUNGSRING	LOCKING RING	CIRCLIPS	D18 type 7000						
11f	1	GRIFF	HANDLE	POIGNEE							
11g	1	MUTTER NYLSTOP	BLOCKING NUT	ECROU FREIN	M8						
12	1	GASBALLAST	GAS BALLAST	LEST AIR		971450810	Incl. 9,11b,12a				
12a	1	MEMBRANE	MEMBRANE	MEMBRANE	D12 X 2 70SH			●			
13	1	RILSAN LEITUNG	RILSAN TUBE	TUBE RILSAN	D4/6 LG165					●	
14	1	SPANNRING	CLAMPING RING	COLLIER DE FIXATION	DN8					●	
15	1	ANKER MIT RINGEN	ROTOR WITH RINGS	ROTOR BAGUE		971442640	Incl. 23b,c,d,e,f,g			●	
16	1	SCHIEBER SATZ VON 3	VANES SET OF 3	JEU DE 3 PALETTES		971429680			●	●	
17	2	O-RING	O-RING	JOINT TOR	D9.12			●		●	
18	1	O-RING	O-RING	JOINT TOR	D110.72			●		●	
19	3	GUMMIFUSS	RUBBER MOUNT	AMORTISSEUR	DN30 H25	71212640					
22	1	RADIAL-DICHTRING	RADIAL SHAFT SEAL	JOINT A LEVRE	D35/D52X6	71420820		●		●	
23	1	MOTOR	MOTOR	MOTEUR	1.5/1.8KW 50/60HZ 230V	971455010	Incl.23a,b,c,d,e,f,g,h,i,j,m,n,p,25,26				
23a	1	ELEKTRISCHER ROTOR	ELECTRICAL ROTOR	ROTOR ELECTRIQUE							
23b	1	MOTOR RING	MOTOR RING	BAGUE ROTOR ELEC.							
23c	1	HEBEOESE VERLAENGERUNG	LIFTING LUG EXTENSION	ENTRETOISE MOTEUR							
23d	1	KUGELLAGER MOTOR	BALL BEARING MOTOR	ROULEMENT BILLES	D25XD47X12						
23e	1	UNTERLEGSCHLEIBE	STOP WASHER	RONDELLE FREIN	MB 5						
23f	1	MUTTER	NUT	ECROU A ENCOCHES KM5	M25X1.5						
23g	1	O-RING	O-RING	JOINT TOR	D47.29						
23h	1	HINTERE LAGERDECKEL MOTOR	REAR END PLATE MOTOR	FLASQUE ARRIERE MOTEUR							
23i	1	STIFTSCHRAUBEN (SATZ VON 4)	TIE ROD (SET OF 4)	TIRANT MOTEUR (JEU DE 4)							
23j	1	SCHALTER 24VDC	POWER RELAY 24VDC	RELAIS DE PUISSANCE 24VDC		971455850					
23m	1	ANLAUF KONDENSATOR	STARTING CONDENSER	CONDENSATEUR DE DEMARRAGE	120µf	971452700					
23n	1	PERMANENT KONDENSATOR	PERMANENT CONDENSER	CONDENSATEUR PERMANENT	40µf	971458950					
23p	1	ANLAUF RELAIS	STARTING RELAY	RELAIS DE DEMARRAGE		71414220					
25	1	MOTOR LÜFTER	MOTOR FAN	VENTILATEUR MOTEUR		971442850					
26	1	MOTOR LÜFTERHAUBE	MOTOR FAN COVER	CAPOT MOTEUR		71421910					
27	1	HEBEOESE VERLAENGERUNG	LIFTING LUG EXTENSION	REHAUSSE ANNEAU DE LEVAGE	H110						
28	1	HEBEOESE	LIFTING LUG	ANNEAU DE LEVAGE	M8					●	
29	1	O-RING	O-RING	JOINT TOR	D82.14			●			
30	1	FEDER	SPRING	RESSORT CLAPET ASPIRATION		71212400					
31	1	ANSAUGVENTIL	INTAKE VALVE	CLAPET ASPI.		71015460		●			
32	1	ANSAUGFLANSCH	INTAKE FLANGE	BRIDE ASPI. EMB.							
33	1	O-RING	O-RING	JOINT TOR	D50			●			
34	1	O-RING	O-RING	JOINT TOR	D42			●			
35	1	FILTER	FILTER	FILTRE EMBOUTI	DN45	71407290					
36	1	ANSAUGFLANSCH	INTAKE FLANGE	BRIDE DE RACCORDEMENT	25KF	971461420					
37	4	BOLZEN	STUD	GOUJON	M8-25/15J=12 Q6.8						
38	4	UNTERLEG SCHEIBE	WASHER	RONDELLE	Z8						

Spare parts

Pos.	Stück. Qty Qté	BENENNUNG	SPECIFICATION	DESIGNATION	Abmessungen (mm) Dimensions (mm) Dimensions (mm)	Bestell-Nr Ref. No. N° de réf	Bemerkungen Notes Remarques	971452150	971443150	971454600	971427660
39	8	MUTTER	NUT	ECROU	H M8 Q6						
40	1	O-RING	O-RING	JOINT TOR	D42.86			●			
42	4	SCHRAUBE	SCREW	VIS	CHC M8X12 Q8.8				●	●	
43	1	VENTILANSCHLAG	VALVE STOP	CONTRE LAME					●	●	
44	1	VENTILPLATTE	VALVE	LAME					●	●	
45	1	O-RING	O-RING	JOINT DE FORME				●			
46	1	ÖLSCHAUGLAS	OIL LEVEL GLASS	VOYANT HUILE	G3/4	71219480			●		
48	1	STOPFEN + O-RING	PLUG + O-RING	BOUCHON	G3/4	971448930	Incl. 48a				
48a	1	O-RING	O-RING	JOINT TOR	D27			●		●	
49	1	SCHLAUCHANSCHLUSS	HOSE CONNECTION	DOUILLE CANNELEE	DN13 - 3/8						
50	1	STOPFEN + O-RING	PLUG + O-RING	BOUCHON	G1 1/4 M - 3/8 F	971444130	Incl.40, 49				
51	4	SCHRAUBE	SCREW	VIS	CHC M8X20						
52	1	AUSPUFFFLANSCH	EXHAUST FLANGE	BRIDE REFOULEMENT	G1 1/4	971453750	Incl. 51,53				
53	1	O-RING	O-RING	JOINT TOR BRIDE REFOULEMENT	D108			●		●	
54	1	FEDER KOMPLETT	SPRING UNIT	RESSORT DE COMPRESSION ENS.		71420370			●	●	
55	1	AUSPUFF-FILTER MIT BYPASS	EXHAUST FILTER WITH BYPASS	CARTOUCHE REFOUL. AVEC BY-PASS		971471470	Incl. 53		●	●	
57	1	SCHWIMMER KOMPLETT	FLOAT COMPL.	FLOTTEUR							
57a	1	ÖLRÜCKFÜHRVENTILKLA PPE	OIL RETURN VALVE SEAL	CLAPET RECUPERATION HUILE				●			
57b	1	O-RING	O-RING	JOINT TOR	D8			●			
58	1	STOPFEN + O-RING	PLUG + O-RING	BOUCHON AVEC JOINT	G 1	971448940	Incl. 58a				
58a	1	O-RING	O-RING	JOINT TOR	D33			●		●	
59	1	ÖLKASTEN OHNE ÖLFILTER	OIL CASING WITHOUT OIL FILTER	CARTER SANS FILTRE A HUILE EQ.		971443290	Incl. 45				
60	1	SCHALTERKABEL 24 V DC 3 m	RELAIS CABLE 24 V DC 3 m	CABLE RELAIS 24 VDC 3 m		971455450					
		DICHTUNGSSATZ	SET OF SEALS	JEU DE JOINTS		971452150					↑
		REPARATUR KIT	REPAIR KIT	KIT REPARATION		971452300					↑
		PUMPENTEIL KOMPL. MIT GB	VACUUM GENERATOR WITH GB	GENERATEUR DE VIDE LA		971454600					↑
		WARTUNGSSATZ	SERVICE KIT	KIT DE MAINTENANCE		971427660					↑

EU Declaration of Conformity

(Translation of original Declaration of Conformity)

The manufacturer: Leybold GmbH
Bonner Strasse 498
D-50968 Köln
Germany

herewith declares that the products specified and listed below which we have placed on the market, comply with the applicable EU Council Directives. This declaration becomes invalid if modifications are made to the product without agreement of Leybold GmbH.

Product designation: SOGEVAC
Type designation: SV16, SV25, SV16D, SV25D, SV200, SV1200, SV16B, SV25B, SV40B, SV65B, SV100B, SV120B (I FC), SV300B, SV470B, SV500B, SV570B, SV630B, SV750B, SV28BI (FC), SV40BI (FC), SV65BI (FC), and their variants, excepted pumps delivered without motor

The products complies to the following European Council Directives:

Machinery Directive (2006/42/EC)

The safety objectives of the Low Voltage Directive 2014/35/EU were complied with in accordance with Appendix 1 No. 1.5.1 of Machinery Directive 2006/42/EC.

Electromagnetic Compatibility (2014/30/EU)

RoHS Directive (2011/65/EU) & (2015/863/EU)

The following harmonized standards have been applied:

- | | |
|---------------------------|---|
| EN 1012-2:1996+A1:2009 | Compressors and vacuum pumps — Safety requirements — Part 2: Vacuum pumps |
| EN 60204-1:2006/A1:2009 | Safety of machinery — Electrical equipment of machines — Part 1: General requirements requirements |
| EN 61000-6-2:2005/AC:2005 | Electromagnetic compatibility (EMC) - Part 6-2: Generic standards - Immunity for industrial environments |
| EN 61000-6-4:2007/A1:2011 | Electromagnetic compatibility (EMC) - Part 6-4: Generic standards - Emission standard for industrial environments |

Documentation officer: Herbert Etges
T: +49(0)221 347 0
F: +49(0)221 347 1250
documentation@leybold.com

Cologne, November 14, 2016

Cologne, November 14, 2016



ppa. Martin Tollner
Head of Product Lines

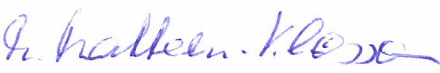

ppa. Dr. Monika Mattern-Klosson
Head of Quality & Business Process Management

Declaration of Contamination of Compressors, Vacuum Pumps and Components

The repair and / or servicing of compressors, vacuum pumps and components will be carried out only if a correctly completed declaration has been submitted. Non-completion will result in delay. The manufacturer can refuse to accept any equipment without a declaration.

A separate declaration has to be completed for each single component.

This declaration may be completed and signed only by authorized and qualified staff.

Customer/Dep./Institute : _____ Address : _____ _____ Person to contact: _____ Phone : _____ Fax: _____ End user: _____	Reason for return: <input checked="" type="checkbox"/> applicable please mark Repair: <input type="checkbox"/> chargeable <input type="checkbox"/> warranty Exchange: <input type="checkbox"/> chargeable <input type="checkbox"/> warranty <input type="checkbox"/> Exchange already arranged / received Return only: <input type="checkbox"/> rent <input type="checkbox"/> loan <input type="checkbox"/> for credit Calibration: <input type="checkbox"/> DKD <input type="checkbox"/> Factory-calibr. <input type="checkbox"/> Quality test certificate DIN 55350-18-4.2.1																																																																
A. Description of the Leybold product: _____ Failure description: _____ Material description : _____ Catalog number: _____ Additional parts: _____ Serial number: _____ Application-Tool: _____ Type of oil (ForeVacuum-Pumps) : _____ Application- Process: _____																																																																	
B. Condition of the equipment <table style="width:100%; border-collapse: collapse;"> <thead> <tr> <th style="width:60%;"></th> <th style="width:10%; text-align: center;">No¹⁾</th> <th style="width:10%; text-align: center;">Yes</th> <th style="width:10%; text-align: center;">No</th> <th style="width:10%;"></th> <th style="width:10%;"></th> <th style="width:10%;"></th> <th style="width:10%;"></th> </tr> </thead> <tbody> <tr> <td>1. Has the equipment been used</td> <td style="text-align: center;"><input type="checkbox"/></td> <td style="text-align: center;"><input type="checkbox"/></td> <td style="text-align: center;"><input type="checkbox"/></td> <td style="text-align: center;">→</td> <td>toxic</td> <td style="text-align: center;"><input type="checkbox"/></td> <td style="text-align: center;"><input type="checkbox"/></td> </tr> <tr> <td>2. Drained (Product/service fluid)</td> <td style="text-align: center;">↓</td> <td style="text-align: center;"><input type="checkbox"/></td> <td style="text-align: center;"><input type="checkbox"/></td> <td></td> <td>corrosive</td> <td style="text-align: center;"><input type="checkbox"/></td> <td style="text-align: center;"><input type="checkbox"/></td> </tr> <tr> <td>3. All openings sealed airtight</td> <td style="text-align: center;">↓</td> <td style="text-align: center;"><input type="checkbox"/></td> <td style="text-align: center;"><input type="checkbox"/></td> <td></td> <td>flammable</td> <td style="text-align: center;"><input type="checkbox"/></td> <td style="text-align: center;"><input type="checkbox"/></td> </tr> <tr> <td>4. Purged</td> <td style="text-align: center;">↓</td> <td style="text-align: center;"><input type="checkbox"/></td> <td style="text-align: center;"><input type="checkbox"/></td> <td></td> <td>explosive ²⁾</td> <td style="text-align: center;"><input type="checkbox"/></td> <td style="text-align: center;"><input type="checkbox"/></td> </tr> <tr> <td colspan="4">If yes, which cleaning agent _____</td> <td></td> <td>radioactive ²⁾</td> <td style="text-align: center;"><input type="checkbox"/></td> <td style="text-align: center;"><input type="checkbox"/></td> </tr> <tr> <td colspan="4">and which method of cleaning _____</td> <td></td> <td>microbiological ²⁾</td> <td style="text-align: center;"><input type="checkbox"/></td> <td style="text-align: center;"><input type="checkbox"/></td> </tr> <tr> <td colspan="4">¹⁾ If answered with "No", go to D. ←</td> <td></td> <td>other harmful substances</td> <td style="text-align: center;"><input type="checkbox"/></td> <td style="text-align: center;"><input type="checkbox"/></td> </tr> </tbody> </table>			No ¹⁾	Yes	No					1. Has the equipment been used	<input type="checkbox"/>	<input type="checkbox"/>	<input type="checkbox"/>	→	toxic	<input type="checkbox"/>	<input type="checkbox"/>	2. Drained (Product/service fluid)	↓	<input type="checkbox"/>	<input type="checkbox"/>		corrosive	<input type="checkbox"/>	<input type="checkbox"/>	3. All openings sealed airtight	↓	<input type="checkbox"/>	<input type="checkbox"/>		flammable	<input type="checkbox"/>	<input type="checkbox"/>	4. Purged	↓	<input type="checkbox"/>	<input type="checkbox"/>		explosive ²⁾	<input type="checkbox"/>	<input type="checkbox"/>	If yes, which cleaning agent _____					radioactive ²⁾	<input type="checkbox"/>	<input type="checkbox"/>	and which method of cleaning _____					microbiological ²⁾	<input type="checkbox"/>	<input type="checkbox"/>	¹⁾ If answered with "No", go to D. ←					other harmful substances	<input type="checkbox"/>	<input type="checkbox"/>
	No ¹⁾	Yes	No																																																														
1. Has the equipment been used	<input type="checkbox"/>	<input type="checkbox"/>	<input type="checkbox"/>	→	toxic	<input type="checkbox"/>	<input type="checkbox"/>																																																										
2. Drained (Product/service fluid)	↓	<input type="checkbox"/>	<input type="checkbox"/>		corrosive	<input type="checkbox"/>	<input type="checkbox"/>																																																										
3. All openings sealed airtight	↓	<input type="checkbox"/>	<input type="checkbox"/>		flammable	<input type="checkbox"/>	<input type="checkbox"/>																																																										
4. Purged	↓	<input type="checkbox"/>	<input type="checkbox"/>		explosive ²⁾	<input type="checkbox"/>	<input type="checkbox"/>																																																										
If yes, which cleaning agent _____					radioactive ²⁾	<input type="checkbox"/>	<input type="checkbox"/>																																																										
and which method of cleaning _____					microbiological ²⁾	<input type="checkbox"/>	<input type="checkbox"/>																																																										
¹⁾ If answered with "No", go to D. ←					other harmful substances	<input type="checkbox"/>	<input type="checkbox"/>																																																										
C. Description of processed substances (Please fill in absolutely) 1. What substances have come into contact with the equipment ? Trade name and / or chemical term of service fluids and substances processed, properties of the substances According to safety data sheet (e.g. toxic, inflammable, corrosive, radioactive) <table border="1" style="width:100%; border-collapse: collapse;"> <thead> <tr> <th style="width:5%;"></th> <th style="width:25%;">Tradename:</th> <th style="width:70%;">Chemical name:</th> </tr> </thead> <tbody> <tr><td>a)</td><td></td><td></td></tr> <tr><td>b)</td><td></td><td></td></tr> <tr><td>c)</td><td></td><td></td></tr> <tr><td>d)</td><td></td><td></td></tr> </tbody> </table>			Tradename:	Chemical name:	a)			b)			c)			d)																																																			
	Tradename:	Chemical name:																																																															
a)																																																																	
b)																																																																	
c)																																																																	
d)																																																																	
2. Are these substances harmful ? <input type="checkbox"/> No <input type="checkbox"/> Yes ← 3. Dangerous decomposition products when heated ? <input type="checkbox"/> No <input type="checkbox"/> Yes ← If yes, which ? _____																																																																	
²⁾ Components contaminated by microbiological, explosive or radioactive products/substances will not be accepted without written evidence of decontamination.																																																																	

D. Legally binding declaration

I / we hereby declare that the information supplied on this form is accurate and sufficient to judge any contamination level.

Name of authorized person (block letters) : _____



_____ Date

_____ signature of authorized person

 firm stamp

Sales and Service

Germany

Leybold GmbH

Sales, Service, Support Center (3SC)
Bonner Strasse 498
D-50968 Cologne
T: +49-(0)221-347 1234
F: +49-(0)221-347 31234
sales@leybold.com
www.leybold.com

Leybold GmbH

Sales Area North

Branch Office Berlin
Industriestrasse 10b
D-12099 Berlin
T: +49-(0)30-435 609 0
F: +49-(0)30-435 609 10
sales.bn@leybold.com

Leybold GmbH

Sales Office South

Branch Office Munich
Karl-Hammerschmidt-Strasse 34
D-85609 Aschheim-Dornach
T: +49-(0)89-357 33 9-10
F: +49-(0)89-357 33 9-33
sales.mn@leybold.com
service.mn@leybold.com

Leybold Dresden GmbH

Service Competence Center

Zur Wetterwarte 50, Haus 304
D-01109 Dresden
Service:
T: +49-(0)351-88 55 00
F: +49-(0)351-88 55 014
info.dr@leybold.com

Europe

Belgium

Leybold Nederland B.V.

Belgisch bijkantoor

Leuvensesteenweg 542-9A
B-1930 Zaventem
Sales:
T: +32-2-711 00 83
F: +32-2-720 83 38
sales.zv@leybold.com
Service:
T: +32-2-711 00 82
F: +32-2-720 83 38
service.zv@leybold.com

France

Leybold France S.A.S.

Parc du Technopolis, Bâtiment Beta
3, Avenue du Canada
F-91940 Les Ulis cedex
Sales and Service:
T: +33-1-69 82 48 00
F: +33-1-69 07 57 38
info.ctb@leybold.com
sales.ctb@leybold.com

Leybold France S.A.S.

Valence Factory
640, Rue A. Bergès
B.P. 107
F-26501 Bourg-lès-Valence Cedex
T: +33-4-75 82 33 00
F: +33-4-75 82 92 69
marketing.vc@leybold.com

Great Britain

Leybold UK LTD.

Unit 9
Silverglade Business Park
Leatherhead Road
Chessington
Surrey (London)
KT9 2QL
Sales:
T: +44-13-7273 7300
F: +44-13-7273 7301
sales.ln@leybold.com
Service:
T: +44-13-7273 7320
F: +44-13-7273 7303
service.ln@leybold.com

Italy

Leybold Italia S.r.l.

Via Trasimeno 8
I-20128 Mailand
Sales:
T: +39-02-27 22 31
F: +39-02-27 20 96 41
sales.mi@leybold.com
Service:
T: +39-02-27 22 31
F: +39-02-27 22 32 17
service.mi@leybold.com

Netherlands

Leybold Nederland B.V.

Floridadreef 102
NL-3565 AM Utrecht
Sales and Service:
T: +31-(30) 242 63 30
F: +31-(30) 242 63 31
sales.ut@leybold.com
service.ut@leybold.com

Switzerland

Leybold Schweiz AG, Pfäffikon

Churerstrasse 120
CH-8808 Pfäffikon
Warehouse and shipping address:
Riedthofstrasse 214
CH-8105 Regensdorf
Sales:
T: +41-44-308 40 50
F: +41-44-302 43 73
sales.zh@leybold.com
Service:
T: +41-44-308 40 62
F: +41-44-308 40 60
service.zh@leybold.com

Spain

Leybold Spain, S.A.

C/. Huelva, 7
E-08940 Cornellà de Llobregat
(Barcelona)
Sales:
T: +34-93-666 43 11
F: +34-93-666 43 70
sales.ba@leybold.com
Service:
T: +34-93-666 46 11
F: +34-93-685 43 70
service.ba@leybold.com

America

USA

Leybold USA Inc.

5700 Mellon Road
USA-Export, PA 15632
T: +1-724-327-5700
F: +1-724-325-3577
info.ex@leybold.com
Sales:
T: +1-724-327-5700
F: +1-724-333-1217
Service:
T: +1-724-327-5700
F: +1-724-325-3577

Brazil

Leybold do Brasil

Rod. Vice-Prefeito Hermenegildo Tonolli,
n°. 4413 - 6B
Distrito Industrial
Jundiá - SP
CEP 13.213-086
Sales and Service:
T: +55 11 3395 3180
F: +55 11 99467 5934
sales.ju@leybold.com
service.ju@leybold.com

Asia

P. R. China

Leybold (Tianjin)

International Trade Co. Ltd.

Beichen Economic
Development Area (BEDA),
No. 8 Western Shuangchen Road
Tianjin 300400
China
Sales and Service:
T: +86-22-2697 0808
F: +86-22-2697 4061
F: +86-22-2697 2017
sales.tj@leybold.com
service.tj@leybold.com

India

Leybold India Pvt Ltd.

No. 82(P), 4th Phase
K.I.A.D.B. Plot
Bommasandra Industrial Area
Bangalore - 560 099
Indien
Sales and Service:
T: +91-80-2783 9925
F: +91-80-2783 9926
sales.bgl@leybold.com
service.bgl@leybold.com

Japan

Leybold Japan Co., Ltd.

Headquarters
Shin-Yokohama A.K.Bldg., 4th floor
3-23-3, Shin-Yokohama
Kohoku-ku, Yokohama-shi
Kanawaga 222-0033
Japan
Sales:
T: +81-45-471-3330
F: +81-45-471-3323
sales.yh@leybold.com

Leybold Japan Co., Ltd.

Tsukuba Technical Service Center
1959, Kami-yokoba
Tsukuba-shi, Ibaraki-shi 305-0854
Japan
Service:
T: +81-29 839 5480
F: +81-29 839 5485
service.iik@leybold.com

Malaysia

Leybold Malaysia

Leybold Singapore Pte Ltd.

No. 1 Jalan Hi-Tech 2/6
Kulim Hi-Tech Park
Kulim, Kedah Darul
Aman 09000
Malaysia
Sales and Service:
T: +604 4020 222
F: +604 4020 221
sales.ku@leybold.com
service.ku@leybold.com

South Korea

Leybold Korea Ltd.

3F. Jellzone 2 Tower
Jeongja-dong 159-4
Bundang-gu Sungnam-si
Gyeonggi-do
Bundang 463-384, Korea
Sales:
T: +82-31 785 1367
F: +82-31 785 1359
sales.bd@leybold.com
Service:
623-7, Upsung-Dong
Cheonan-Si
Chungcheongnam-Do
Korea 330-290
T: +82-41 589 3035
F: +82-41 588 0166
service.cn@leybold.com

Singapore

Leybold Singapore Pte Ltd.

8 Commonwealth Lane #01-01
Singapore 149555
Singapore
Sales and Service:
T: +65-6303 7030
F: +65-6773 0039
sales.sg@leybold.com
service.sg@leybold.com

Taiwan

Leybold Taiwan Ltd.

No 416-1, Sec. 3
Chungshin Rd., Chutung
Hsinchu County 310
Taiwan, R.O.C.
Sales and Service:
T: +886-3-500 1688
F: +886-3-583 3999
sales.hc@leybold.com
service.hc@leybold.com

Headquarter

Leybold GmbH

Bonner Strasse 498
D-50968 Cologne
T: +49-(0)221-347-0
F: +49-(0)221-347-1250
info@leybold.com



www.leybold.com