

# SEREN

INDUSTRIAL POWER SYSTEMS INC.

---

## R301 RADIO FREQUENCY POWER SUPPLY OPERATOR'S MANUAL

Revision: 0.05  
Standard Configuration

**PRELIMINARY**  
**SERIAL INTERFACE NOT IMPLEMENTED**

Document Number 6100130000



FOR SALES AND SERVICE PLEASE CALL:

**PTB SALES**    T :: 626.334.0500  
service@ptbsales.com  
www.ptbsales.com

DATE SERVICED: \_\_\_\_\_

***VIEW OUR INVENTORY***

SEREN Industrial Power Systems, Inc.  
1717 Gallagher Drive  
Vineland, New Jersey, 08360  
U.S.A

Telephone:    856-205-1131  
Fax:            856-205-1141  
E-mail:        [info@serenips.com](mailto:info@serenips.com)

Copyright © 2003, 2004 Seren IPS Inc.

---

## Introduction

Thank you for acquiring your new SEREN IPS product. The R301 Radio Frequency Power Supply has been designed to provide the best value, ease of operation, and reliability for plasma processing systems. This manual covers specifications, installation, and operation of the R301 RF Power Supply.

## Information

To get answers for any questions you might have regarding your plasma or processing system, please contact your system vendor first. Your system vendor knows the intimate details of how your equipment interfaces and operates with the R301 RF Power Supply and can efficiently resolve system related problems.

For questions directly related to the R301 RF Power Supply, you may call us, Monday through Friday, 8:00am to 5:00pm, United States Eastern Time, at:

**1-856-205-1131**

## Service

For RF Power Supplies purchased with a processing system, or covered under a service contract from your system vendor, please contact the system vendor to arrange for service.

For after-market or end user customers, a SEREN IPS customer service representative will arrange for service. Call us, Monday through Friday, 8:00am to 5:00pm, United States Eastern Time, at: **1-856-205-1131**

Please note: Equipment returned to us without prior authorization or without a Return Materials Authorization (RMA) number visible on the outside of the package will be refused.

## How to Contact Us

Our address, telephone, and fax numbers are listed below.

SEREN Industrial Power Systems, Inc.  
1717 Gallagher Drive  
Vineland, New Jersey, 08360 U.S.A.

Telephone: 856-205-1131  
Fax: 856-205-1141

## Proprietary Information Notice

This document contains information proprietary to SEREN IPS Inc. This document shall not be reproduced or its contents disclosed without the written permission of SEREN IPS Inc. This notice shall appear in all copies.

## TABLE OF CONTENTS

Safety Notes .....	3
R301 RF Power Supply Features .....	5
Physical Dimensions .....	6
Installation .....	8
Front Panel Controls and Display .....	10
Operation .....	12
Basic Front Panel Operation .....	12
Analog Interface Operation .....	16
Serial Interface Operation .....	18
Configuring Programmable Parameters .....	27
Programmable Parameter Reference .....	27
Programmable Parameter Details .....	29
Rear Panel Controls and Connections .....	34
CEX IN Connector .....	35
CEX OUT Connector .....	35
Analog Interface Connector Pin List and Functional Description .....	36
Typical Interface Circuits .....	41
Serial Interface Connector Pin List and Functional Description .....	44
Typical Interface Connections .....	45
Probe Inverter Option Connections .....	46
Typical System Configuration .....	48
Maintenance .....	49
Problem Solving .....	50
Technical Data .....	52
SEREN 1 Year Limited Warranty .....	54
Obtaining Service for the R301 RF Power Supply .....	54
Glossary of Terms .....	55
Revision History .....	57

## Safety Notes

The R301 RF Power Supply has been designed and tested to meet strict safety requirements. These include independent lab examination and approval, and compliance to established standards. Please read the following instructions carefully before operating the R301 RF Power Supply and refer to them as needed to ensure the continued safe operation of the R301 RF Power Supply.

**Follow** all warnings and instructions marked on or supplied with the product.

### Symbology:

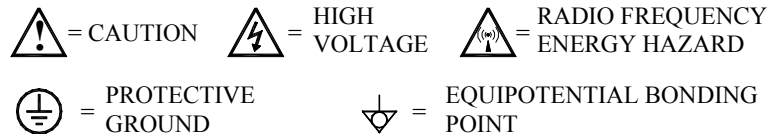

**Unplug** or disconnect this equipment from the power source before cleaning or re-configuring the AC mains voltage.

**Do not** use this equipment near water, wet locations, or outdoors.

**Do not** place this equipment on an unstable cart, stand, or table. The R301 RF Power Supply may fall, causing personal injury or damage to the R301 RF Power Supply .

**This product** is equipped with a 3-wire power cord and grounding type plug. This is a safety feature. To avoid electric shock, this unit must be connected to the power source in compliance with the National Electrical Code ANSI C1 and/or any other codes applicable to the user. Improper installation may result in a shock or fire hazard.

**It is the responsibility** of the installer to provide a proper protective ground from the R301 RF Power Supply to earth ground, in accordance with local and national electrical codes, and any other codes applicable to the user.

R301 RF Power Supply should be operated from the type of power source indicated by the ratings plate. If you are not sure of the type of power available, consult an electrician or your local power company.

**The power supply cord and plug** is the disconnect device for this equipment. If the plug is removed from the cord and the power cord is hard wired to the power source, it is the responsibility of the installer to provide a disconnect device.

**Do not** allow anything to rest on the power cord or interconnecting cables. Do not locate the R301 RF Power Supply where persons will step on the power or interconnecting cables.

**Slots and Openings** in the equipment's chassis are provided for ventilation. To ensure reliable operation of the R301 RF Power Supply, these openings must not be blocked, covered, or restricted. Restricting the air inlets or exhaust will cause the unit to overheat. Sustained over temperature conditions may degrade or damage the unit.

**Never** push objects of any kind into the slots and openings of the R301 RF Power Supply's enclosure. They may touch dangerous voltage points or short out parts, which could result in a fire or electric shock.

**Never** spill liquid of any kind on or into the R301 RF Power Supply.

**Never** remove covers or guards that require a tool for removal. There are no operator serviceable areas within these covers. Refer servicing to qualified service personnel.



## **CAUTION!**



**ELECTRICAL SHOCK HAZARD PRESENT  
INSIDE UNIT, AT THE RF OUTPUT  
CONNECTOR, AND AT THE MAINS INPUT  
CONNECTOR.  
DO NOT REMOVE COVERS.  
REFER SERVICING TO QUALIFIED SERVICE  
PERSONNEL.**

### **R301 Radio Frequency Power Supply Features**

The R301 RF Power Supply is intended for use with radio frequency plasma processing systems and radio frequency processing applications.

The R301 RF Power Supply provides a 13.56MHz, level-controlled radio frequency power output up to 300 Watts. The R301 RF Power Supply provides operator-accessible controls, a visual display of power supply status, and a control interface to the user's processing system. Other R301 features are listed below:

- ½ Rack, 3U High Package
- 98-125VAC or 198-250VAC AC Mains
- Crystal-controlled internal frequency source
- Bright, easy to read 4 Line Vacuum Fluorescent Display, capable of displaying Forward and Reflected RF Power, Control Mode, Power Supply status, and RF or DC Probe Voltage.
- Front panel controls for RF On/Off, mode selection, and programming
- Front Panel, Analog, and Serial control interfaces
- Forward Power and Load (Net) Power Leveling
- Scalable Forward and Reflected power metering (requires interface connection to user's system)
- Scalable RF and DC Probe Voltage display
- Remote control operation via analog system interface connector
- Common Exciter input and output
- Voltage Probe Inverter Option Available
- Air cooled

**Physical Dimensions**

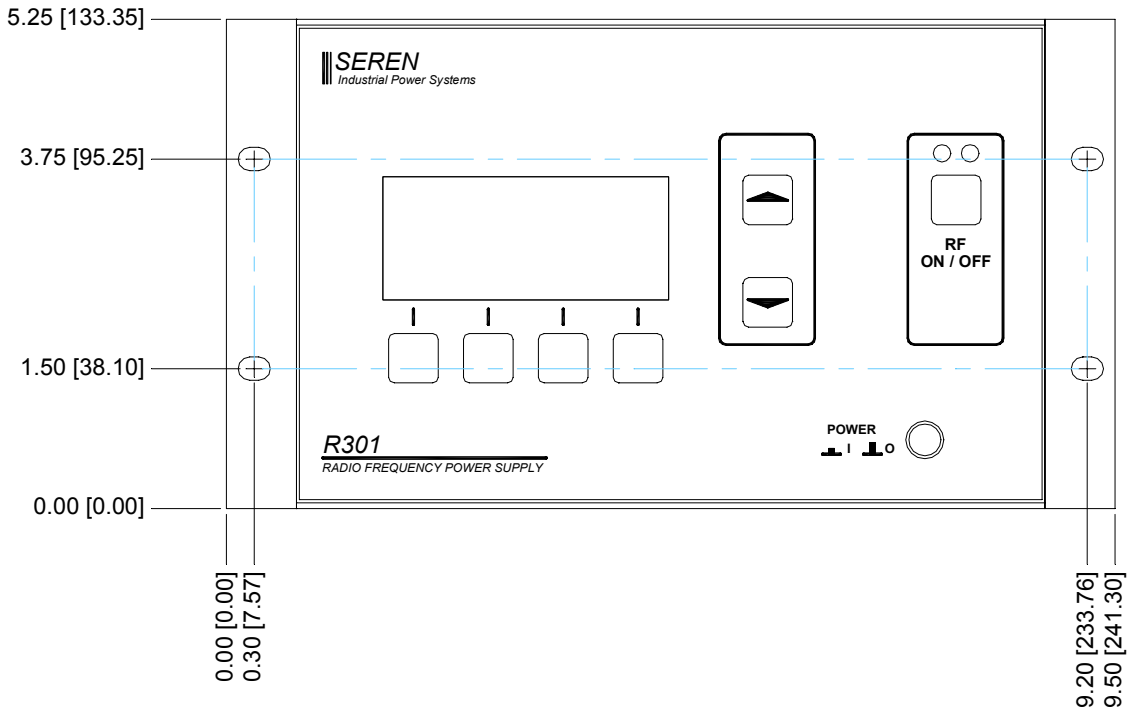

Front View, R301 RF Power Supply  
Dimensions in Inch [mm]

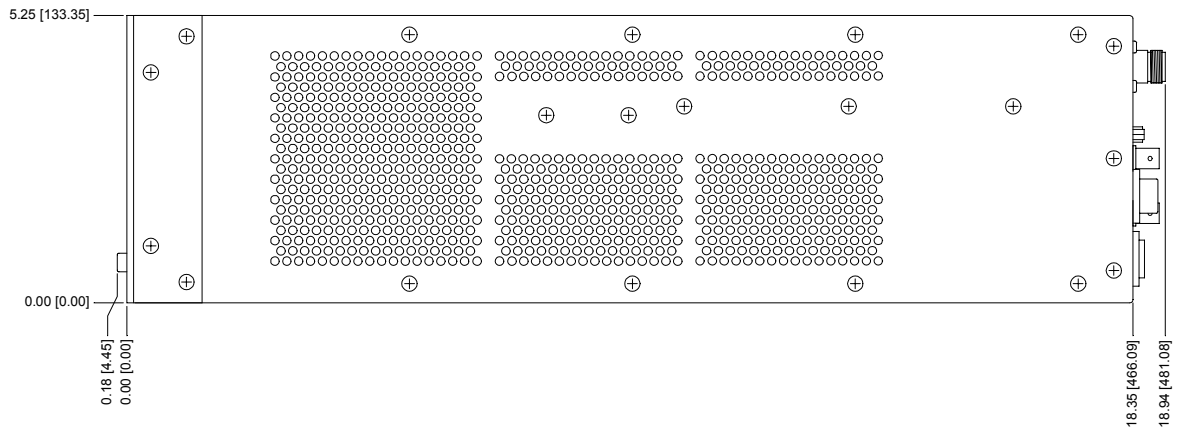

Side View, R301 RF Power Supply  
Dimensions in Inch [mm]

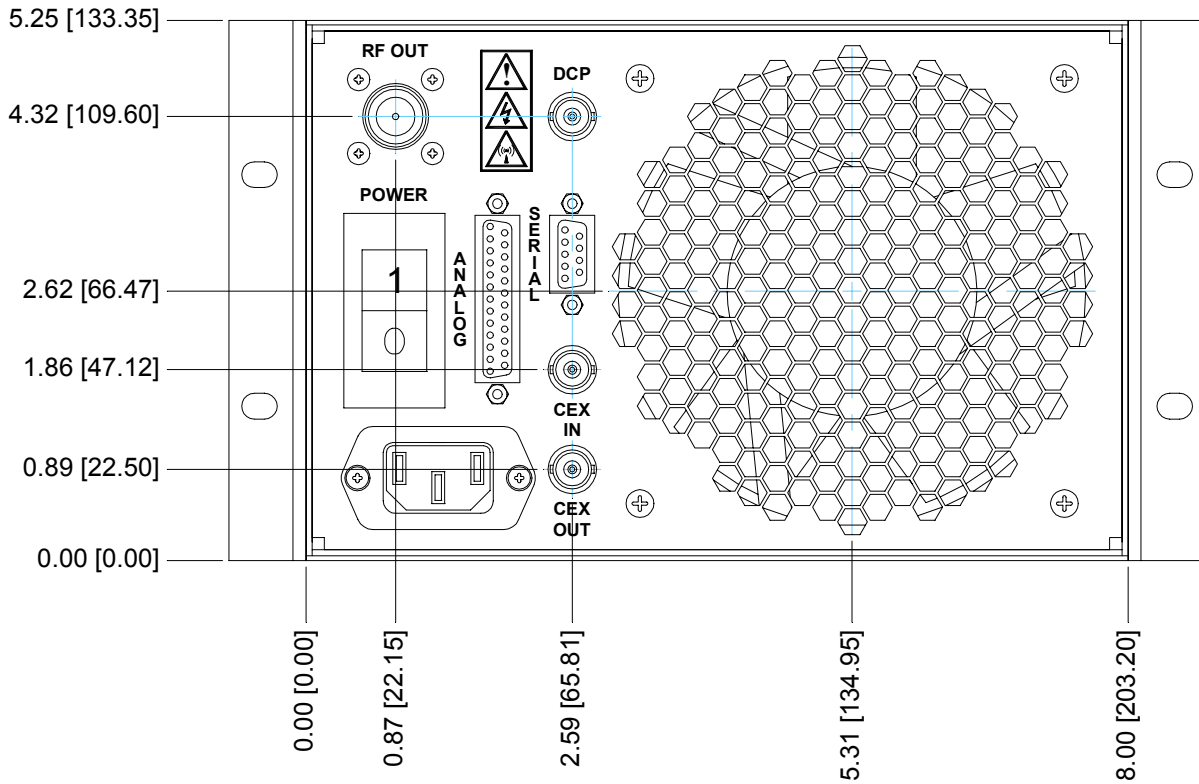

Rear View, R301 RF Power Supply  
 Dimensions in Inch [mm]



**Installation:**

**Recommended mounting:**

The R301 RF Power Supply is designed for placement on a tabletop or on a shelf within an equipment rack, with another ½ Rack 3U piece of equipment, in a clean environment. The table or equipment rack must be capable of supporting the full weight of the unit.

The R301 RF Power Supply is supplied with ½-Rack Mounting Ears. The mounting ears are designed for securing the R301 to the equipment rack rail. The ½-rack mounting ears ***are not*** designed to support the weight of the R301 RF Power Supply. The user must provide a shelf within the equipment rack to support the weight of R301. The user is responsible for providing mounting hardware.

**Note: the weight of the R301 RF Power Supply  
is 43 pounds (19.5 kg)**

**Optional Mounting:**

One (1) R301 RF Power Supply may be mounted in a 19” equipment rack with the use of the optional single rack mount kit. The user must provide a shelf within the equipment rack to support the weight of R301 unit.

Two (2) R301 RF Power Supplies in a 19” equipment rack with the use of the optional dual rack mount kit. The user must provide a shelf within the equipment rack to support the weight of two (2) R301 units.

**Supplied Accessories:**

Description	Quantity	Seren Part Number
½-Rack Mount Ear, 3U	2	4304870000
Power Cord (for 98-125V models) 14AWG, IEC320-13 Receptacle to NEMA 5-15 Plug	*	4500910000
Power Cord (for 198-250V models) 14AWG, IEC320-13 Receptacle to NEMA L6-15 Plug	*	4500910001

\* Only 1 power cord is supplied with the R301 RF Power Supply. The power cord type depends on the AC Mains voltage specified at time of order.

**Connection to AC Mains:**

**BEFORE connecting the R301 RF Power Supply the AC mains,** verify the AC Mains voltage marked on the ratings plate, located on the top panel of the R301 RF Power Supply, is compatible with your AC Mains voltage. If the AC Mains voltage on the ratings plate is not compatible with your AC Mains voltage, contact a Seren IPS Inc. service depot and arrange to have the mains voltage re-configured.

**Note:** Incorrect AC Mains voltage may damage the R301 RF Power Supply. The AC Mains voltage ***is not*** field configurable.

**RF Output Connection:**

Connect the R301 RF Power Supply's RF output to a suitable load via a coaxial cable. Depending on the load configuration and application, several coaxial cable types may be used. Consult with the Seren IPS Inc. sales department, customer service department, or a Seren IPS Inc. representative to select the cable appropriate to your installation.

Coaxial cable types RG-213/U, RG-225/U or RG-393/U are typically used with R301 RF Power Supply installations.

**System Interfacing:**

The R301 RF Power Supply can be used "stand-alone" or can be interfaced with a processing system. There are five (5) connectors on the rear panel dedicated to system interfacing. Refer to the Rear Panel Controls and Connections for detailed pin lists and signal descriptions. There are many possible interface schemes – a full discussion of interface schemes is beyond the scope of this document. Contact the Seren IPS Inc. customer service department if you require assistance with interface connections. A brief summary of the connectors is listed below.

"Analog Control" Connector

Provides status and control signals for an external system controller to operate the R301 RF Power Supply. The EXTERNAL INTERLOCK circuit *must* be completed or the R301 will not turn on. Refer to the Rear Panel Controls and Connections section for details.

"Serial Interface" Connector

Serial communications port for computer control via RS-232 protocol.

"CEX IN" Connector

Radio Frequency signal input. The R301 uses the signal present at this connector as the frequency source when the R301 is configured for "slave" operation in a multiple RF power supply system.

"CEX OUT" Connector

Radio Frequency signal output. The signal present at this connector is the same frequency the R301 is using to produce its RF output. This signal can be used as a frequency signal source for other RF Power supplies in a multiple RF power supply system.

"DCP" Connector (optional)

Voltage Probe Inverter input. When installed, a 0 to -10VDC signal applied to this connector produces a 0 to +10VDC output on pin 25 of the Analog Interface connector. This optional circuit inverts the output of a passive DC Voltage Probe, such as used in the Seren IPS Inc. MM-Series and PM-Series matching networks, when using external feedback for power regulation (voltage control).

**Front Panel Controls and Display:**

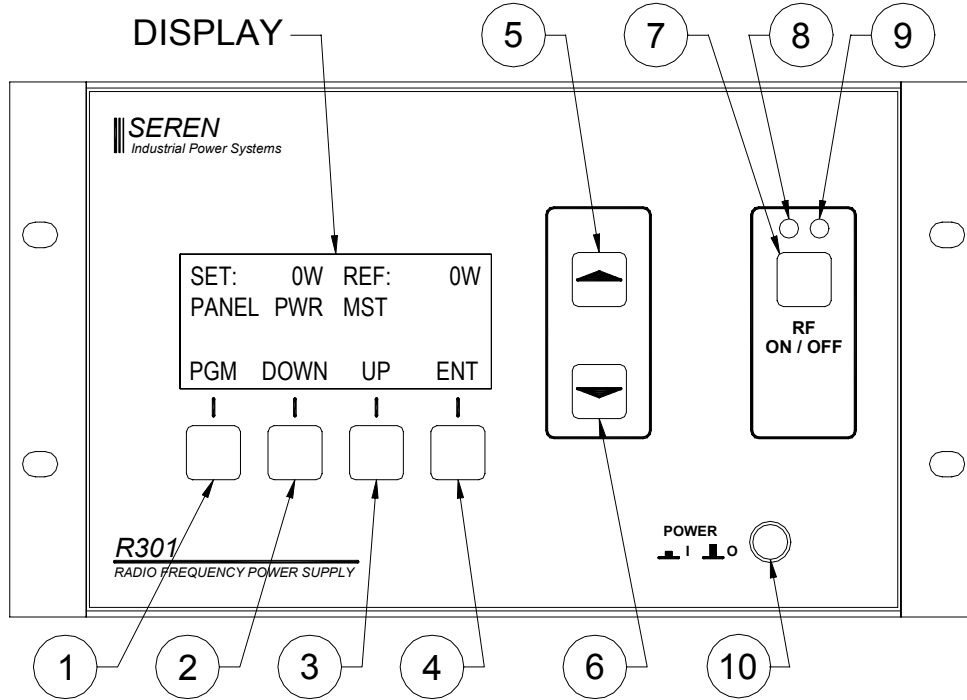

**Buttons**

Item	Name	Description
1	Program/Run	Toggles the R301 RF Power Supply between the RUN mode and PROGRAM mode. In Program mode, display line 3 changes to show Programmable Menu Entry Options. The button legend changes from “PGM” to “RUN” when in the Program mode.
2	Down	Moves down the programming menu
3	Up	Moves up the programming menu
4	Enter	Programs (saves) changes made to a parameter
5	Value Up	Changes Parameter Value - Increment
6	Value Down	Changes Parameter Value - Decrement
7	RF ON/OFF	Enables/Disables the RF output in “local” mode, disables the RF output in any operational mode.
8	RF ON Indicator Lamp	Glows RED when the RF Output is enabled (on).
9	RF OFF Indicator Lamp	Glows BLUE when the RF output is disabled (off)
10	Power	AC Mains power enable/disable

**Display**

The front panel display shows the operational status of the R301 RF Power Supply and provides legends for the keypad.

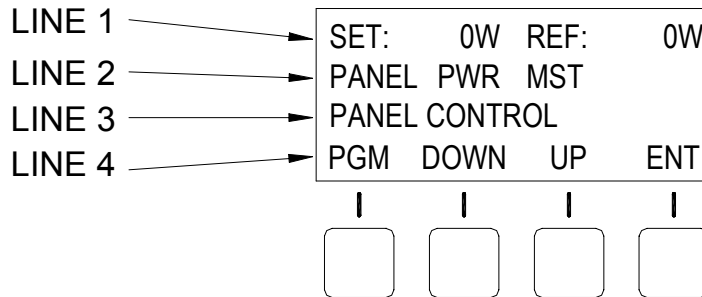

Line	Description
1	Power Display Line Displays power setpoint and reflected power when the RF Output is disabled. Displays forward power (or load power) and reflected power when the RF output is enabled
2	Status Display Line Displays the current control source, power control mode, exciter mode and operational alarms. Operational alarms are flashed on the extreme right side of the line (see the problem solving section for alarm details). <b>[CONTROL SOURCE] [POWER CONTROL MODE] [EXCITER MODE] [ALARM]</b> Control Source: Panel = Front Panel Control Analog = Analog Interface Serial = Serial Interface Power Control Mode: PWR = Forward Power Leveling (internal power sensor) PLS = Pulsing Enabled (internal power sensor) VLT = Voltage Control (external feedback) Exciter Mode: MST = Master (internal frequency source) EXT = External (external frequency source)
3	User Configurable Display Line In RUN mode: Displays DC Voltage Probe or RF Voltage Probe output (User enabled or disabled) In PROGRAM mode: Displays a programmable parameter and its current setting.
4	Keypad Menu – button legends change depending on mode

## **Operation**

Front panel operation of the R301 RF Power Supply is simple. This section describes the use and operation of the front panel controls in a “how to...” manner. Refer to the front panel illustration on the previous page for item references.



Connect the R301's RF output to a 50-Ohm, 500 Watt resistive load, Impedance Matching network, processing system or other suitable load before enabling AC mains Power.

### **Basic Front Panel Operation**

#### Mains Power On/Off:

Press the POWER button (item 10) to enable mains power – the front panel display will illuminate and momentarily display the firmware revision and copyright. Press the POWER button again to disable mains power.

#### Control Source:

The control source is the control interface for the R301 RF Power Supply. The R301 RF Power Supply has three (3) user-selectable control sources.

- The “PANEL” control source is for front panel operation of the R301.
- The “ANALOG” control source is for controlling the R301 from the user's system, via the rear panel ANALOG INTERFACE connector.
- The “SERIAL” control source is used for controlling the R301 from a computer, via an RS-232, RS-422, or RS-485 interface.

To select a control source, follow the directions below:

#### PANEL control:

To change the control source to the front panel,

1. Press the PGM button (Item 1) once.
2. Press the DOWN button (item 2) or the UP button (item 3) until line 3 of the display shows the current control source (PANEL CONTROL, ANALOG CONTROL, or SERIAL CONTROL).
3. Press the VALUE UP button (item 5) or the VALUE DOWN button (item 6) until PANEL CONTROL is displayed on line 3.
4. Press the ENT button (item 5) to save the selection.
5. Press the RUN button (item 1) to return to exit the programming menu.

#### ANALOG control:

To change the control source to the Analog interface connector,

1. Press the PGM button (Item 1) once.

2. Press the DOWN button (item 2) or the UP button (item 3) until line 3 of the display shows the current control source (PANEL CONTROL, ANALOG CONTROL, or SERIAL CONTROL).
3. Press the VALUE UP button (item 5) or the VALUE DOWN button (item 6) until ANALOG CONTROL is displayed on line 3.
4. Press the ENT button (item 5) to save the selection.
5. Press the RUN button (item 1) to return to exit the programming menu.

**SERIAL control:**

To change the control source to the Serial interface connector,

1. Press the PGM button (Item 1) once.
2. Press the DOWN button (item 2) or the UP button (item 3) until line 3 of the display shows the current control source (PANEL CONTROL, ANALOG CONTROL, or SERIAL CONTROL).
3. Press the VALUE UP button (item 5) or the VALUE DOWN button (item 6) until SERIAL CONTROL is displayed on line 3.
4. Press the ENT button (item 5) to save the selection.
5. Press the RUN button (item 1) to return to exit the programming menu.

Note: Pressing the RUN button (item 1) automatically saves the current setting *and* exits the programming menu.

Note: The control source and control mode selection is saved when the R301 RF Power Supply is powered down – it will power-up in the same mode.

**Leveling Mode:**

The leveling mode is the method the R301 uses to regulate its output power. There are three (3) leveling mode selections.

- The “PWR” (power) leveling mode uses the R301’s internal power sensor to regulate the RF output power. There are two types of power leveling available on the R301 RF Power Supply:
  1. Forward (FWD) Power leveling: The forward output power is measured by the R301’s internal power sensor and compared against the requested output power (power setpoint). The R301’s power amplifier increases or decreases its output to maintain the requested power setpoint. Reflected power is displayed and monitored for internal protection.
  2. Load Power Leveling: The forward and reflected power is measured by the R301’s internal power sensor. The reflected power signal is subtracted from the forward power signal and compared against the requested net power (power setpoint) to be delivered to the load. The R301’s power amplifier output increases or decreases its output to maintain the net power delivered to the load. Reflected power is displayed and monitored for internal protection.

- The “VOLTAGE” (VLT) leveling mode uses an external feedback voltage (derived from a Voltage Probe in the processing system’s matching network or processing chamber) to regulate the RF output power.

To select a leveling mode, follow the directions below:

Forward (FWD) Power Leveling mode:

1. Press the “PGM” button (item 1).
2. Press the “DOWN” button (item 2) 4 times, or until line three of the display is “POWER CONTROL” or “VOLTAGE CONTROL”
3. Press the “VALUE UP” button (item 5) or “VALUE DOWN” (item 6) until line 3 of the display indicates the desired power leveling mode, “POWER CONTROL”.  
The text on the left side of display line 2 should change to “PANEL PWR”
4. Press the “ENT” button (item 4) to save the mode selection.
5. Press the “DOWN” button (item 2) 2 times, or until line three reads “FWD POWER LEVELING” or “LOAD POWER LEVELING”
6. Press the “VALUE UP” button (item 5) or “VALUE DOWN” (item 6) until line 3 of the display indicates the desired power leveling mode, “FWD POWER LEVELING”.
7. Press the “ENT” button (item 4) to save the mode selection.
5. Press the “RUN” button (item 1) to exit the programming menu.

Voltage (VLT) Leveling mode:

1. Press the “PGM” button (item 1).
2. Press the “DOWN” button (item 2) 4 times, or until line 3 of the display is “POWER CONTROL” or “VOLTAGE CONTROL”
3. Press the “VALUE UP” button (item 5) or “VALUE DOWN” (item 6) until line 3 of the display indicates the desired power leveling mode, “VOLTAGE CONTROL”.  
The text on the left side of display line 2 should change to “PANEL VLT”
4. Press the “ENT” button (item 4) to save the mode selection.
5. Press the “RUN” button (item 1) to exit the programming menu.

Load (VLT) Power Leveling mode:

1. Press the “PGM” button (item 1).
2. Press the “DOWN” button (item 2) 4 times, or until line three of the display is “POWER CONTROL” or “VOLTAGE CONTROL”
3. Press the “VALUE UP” button (item 5) or “VALUE DOWN” (item 6) until line 3 of the display indicates the desired power leveling mode, “POWER CONTROL”.  
The text on the left side of display line 2 should change to “PANEL PWR”
4. Press the “ENT” button (item 4) to save the mode selection.
5. Press the “DOWN” button (item 2) 2 times, or until line three reads “FWD POWER LEVELING” or “LOAD POWER LEVELING”

6. Press the "VALUE UP" button (item 5) or "VALUE DOWN" (item 6) until line 3 of the display indicates the desired power leveling mode, "LOAD POWER LEVELING".
7. Press the "ENT" button (item 4) to save the mode selection.
8. Press the "RUN" button (item 1) to exit the programming menu.

#### Set Output Power Level

1. Ensure the R301 RF Power Supply is in the "RUN" mode – the legend above the Program/Run button (item 1) is "PGM".
2. Use the Value Up button (item 5) or Value Down button (item 6) to adjust the power setpoint (SET: XXXW on the front panel display) to the desired power level.

#### Enable RF Output

1. Ensure the R301's RF output is connected to an appropriate load and the external interlock (Analog Interface Connector, pin 2) is in the proper state.
2. Press the front panel RF ON/OFF button (item 7). The blue RF OFF lamp will extinguish (item 9) and the red RF ON lamp will illuminate.
3. The left side of line one on the display will change from "SET XXXW" to "FWD XXXW"

#### Disable RF Output

1. Press the front panel RF ON/OFF button (item 7). The red RF ON lamp should extinguish (item 9) and the blue RF OFF lamp will illuminate.
2. The left side of line one on the display will change from "FWD XXXW" to "SET XXXW"



## Basic Analog Interface Operation

Refer to the Rear Panel Controls and Connections and the Typical Interface Connections sections for detailed analog interface operation and connection information.



Connect the R301's RF output to a 50-Ohm, 500 Watt resistive load, Impedance Matching network, processing system or other suitable load before enabling AC mains Power.

1. Make control connections to the rear panel ANALOG INTERFACE connector.
2. Press the front panel POWER button (item 10) to enable mains power – the front panel display will illuminate and momentarily display the firmware revision and copyright.
3. Select ANALOG control mode.

Note: The ANALOG control mode only needs to be selected once. The R301 RF power supply will retain the selected control mode during a power-off/power-on cycle.

- a. Press the PGM button (Item 1) once.
  - b. Press the DOWN button (item 2) or the UP button (item 3) until line 3 of the display shows the current control source (PANEL CONTROL, ANALOG CONTROL, or SERIAL CONTROL).
  - c. Press the VALUE UP button (item 5) or the VALUE DOWN button (item 6) until ANALOG CONTROL is displayed on line 3.
  - d. Press the ENT button (item 5) to save the selection.
  - e. Press the RUN button (item 1) to exit the programming menu.
4. Select the desired leveling mode “Power” or “Voltage”.

Apply an open circuit or TTL “high” signal to Analog Interface Connector pin 4 to select the power supply's internal power sensor for power regulation. A contact closure between Analog Interface Connector pin 4 and pin 16 or a TTL “low” signal applied to pin 4 selects forward power regulation based on an external feedback signal (FEEDBACK signal – Analog Interface Connector pins 12 and 24).

5. Apply the desired setpoint voltage to pins 21 and 23
6. Enable the Analog Interface Connector's external interlock (INTERLOCK) circuit. Connect Analog Interface connector pin 2 to pin 15 or apply a TTL logic “low” signal to pin 2.
7. Enable the Analog Interface Connector's RF On (RFON\*) circuit. Connect Analog Interface Connector pin 3 to pin 16 or apply a TTL logic “low” signal to pin 2.



Note: the RFON\* signal is edge triggered. A transition from a TTL “high” to TTL “low” logic state must occur to enable the RF output. This prevents accidental enabling of the RF output when the RF power supply is powered-up in the ANALOG control mode or when the external interlock (INTERLOCK) is re-established after an external system interlock event.

8. Adjust the setpoint voltage as required.
9. Disable the RF Output. Open the connection between Analog Interface Connector pin 3 to pin 16 or apply a TTL logic “High” signal to pin 2.

**Basic Serial Interface Operation <SERIAL INTERFACE NOT IMPLEMENTED>**

Refer to the Rear Panel Controls and Connections section for serial interface connection details. Serial commands are detailed in the Serial Commands Section.

Serial interface protocol is RS-232, with 8 data bits, 1 stop bit, no parity. The baud rate is selectable, 19200 Baud or 9600 Baud (see below). The factory default baud rate is 19,200 baud.



Connect the R301's RF output to a 50-Ohm, 500 Watt resistive load, Impedance Matching network, processing system or other suitable load before enabling AC mains Power.

1. Connect a terminal, personal computer, or system controller to the rear panel SERIAL interface connector.
2. Press the front panel POWER button (item 10) to enable mains power – the front panel display will illuminate and momentarily display the firmware revision and copyright.
3. Select SERIAL control mode.

Note: The SERIAL control mode only needs to be selected once. The R301 RF power supply will retain the selected control mode during a power-off/power-on cycle.

- a. Press the PGM button (Item 1) once.
  - b. Press the DOWN button (item 2) or the UP button (item 3) until line 3 of the display shows the current control source (PANEL CONTROL, ANALOG CONTROL, or SERIAL CONTROL).
  - c. Press the VALUE UP button (item 5) or the VALUE DOWN button (item 6) until SERIAL CONTROL is displayed on line 3.
  - d. Press the ENT button (item 5) to save the selection.
  - e. Remain in the programming environment, ***do not*** press the RUN button.
4. Select the BAUD rate:  
Serial control must be selected before attempting to select the baud rate. If the R301 is set for PANEL or ANALOG control mode, the baud rate selection will not appear in the programming menu.

Note: The BAUD rate only needs to be selected once. The R301 RF power supply will retain the selected BAUD rate during a power-off/power-on cycle.

- a. Press the DOWN button (item 2) or the UP button (item 3) until line 3 of the display shows the current baud rate (19200 BAUD or 9600 BAUD).
- b. Press the VALUE UP button (item 5) or the VALUE DOWN button (item 6) until the desired baud rate is displayed on line 3
- c. Press the ENT button (item 5) to save the selection.

- d. Press the RUN button (item 5) to exit the programming menu.
- 5. Send the desired serial command to the R301 RF Power Supply.

**Serial Commands**

The underscore character ( \_ ) indicates a space, terminators are specified as carriage return–line feed <crLf> or carriage return <cr>.

Unless otherwise specified, with ECHO mode set to *disabled*, the RF Power Supply responds with “<prompt><cr>” for an accepted command, or “N<cr>” for an invalid command.

Unless otherwise specified, with ECHO mode set to *enabled*, the RF Power Supply responds with “<prompt><command string><cr>” and a command response (where applicable) for an accepted command, or “N<cr>” for an invalid command.

The prompt character is the greater-than (>) symbol.

SERIAL COMMAND DETAILS

Command:	Command Detail:
***	Assert SERIAL control mode. <b>Command:</b> ***<cr> <b>Response:</b> <prompt><cr>
Q	Query RF Power Supply Status Returns the current status of the R301 RF Power Supply, in the form of a mapped string, terminated with <cr>. <b>Command:</b> Q<cr> <b>Response:</b> XXXXXXXX_aaaa_bbbb_ccc_dddd<cr> Where: aaaa is the setpoint, in Watts bbbb is the Forward Power, in Watts ccc is Reflected Power, in Watts dddd is the maximum power, in Watts  XXXXXXX is a 7-character ASCII mapped string as described below (characters are counted left-to-right):  <u>Character # 1: Control Source</u> 2 = Serial Interface, 1 = Analog Interface, 0 = Front Panel  <u>Character # 2: RF Output Regulation Feedback Source</u> 3 = Internal Sensor (RF Power Control) 0 = External FEEDBACK signal (DC Voltage Control)

Character #3: Setpoint Source

2 = Serial Interface, 1 = Analog Interface, 0 = Front Panel

Character #4: Status Flags (bit-mapped ASCII)

Bit 3: 1 = RF ON, 0 = RF OFF

Bit 2: 1 = Reflected Limit active, 0 = Reflected Limit inactive

Bit 1: 1 = Max Power Limit active, 0 = Max Power Limit inactive

Bit 0: 1 = PA Current Limit active, 0 = PA Current Limit inactive

Character #5: Status Flags (bit-mapped ASCII)

Bit 3: 1 = RFON&OK, 0 = Ref Power alarm threshold exceeded

Bit 2: 1 = Dissipation Limit active, 0 = Dissipation Limit inactive

Bit 1: 1 = CEX is in Slave Mode, 0 = CEX is in Master Mode

Bit 0: 1 = Pulse Mode active, 0 = Pulse Mode inactive

Character #6: Status Flags (bit-mapped ASCII)

Bit 3: Not Used/Reserved

Bit 2: Not Used/Reserved

Bit 1: 1 = External Interlock OK, 0 = External Interlock open

Bit 0: 1 = Temperature Alarm active, 0 = Temperature Alarm inactive

Character #7: Not Used/reserved

- V?                      Query the Control Voltage  
 Responds with the external feedback (or DC Bias) Voltage, with Probe Attenuation and scaling factors applied. Because The R301 only has one external feedback channel, this command is identical to the "0?" command. A negative (-) polarity signal is assumed.  
**Command:** V?  
**Response:** -XXXX
- LVL?                    Query Power Leveling Mode  
 Returns the current power leveling mode:  
**Command:** LVL?<cr>  
**Response:**  
 0<cr> for Forward Power Leveling  
 1<cr> for Load (net) Power Leveling
- 0?                      Query the DC Bias Voltage  
 Responds with the external feedback (or DC Bias) Voltage, with Probe Attenuation and scaling factors applied. Because The R301 only has one external feedback channel, this command is identical to the "V?"

command. A negative (-) polarity signal is assumed.

**Command:** 0?

**Response:** -XXXX

- DR** Select VOLTAGE CONTROL mode  
Selects the Analog Interface connector's FEEDBACK signal as the feedback source for regulating the RF output level. Related commands: "V?", "0?", and "V".  
**Command:** DR<cr>  
**Response:** <prompt><cr>
- IR** Select POWER CONTROL mode  
Selects the R301's internal power sensor as the feedback source for regulating the RF output level. Used in conjunction with the "DL", "EL", and "W" commands.  
**Command:** IR  
**Response:** <prompt><cr>
- DL** Select FORWARD POWER leveling  
Configures the R301 to deliver a constant Forward Power the load. The power setpoint is set by the front panel controls or the "W" serial command.  
**Command:** DL<cr>  
**Response:** <prompt><cr>
- EL** Select LOAD POWER leveling  
Configures the R301 to deliver a constant Net Power to the load. Net Power = (Forward Power – Reflected Power). The power setpoint is set by the front panel controls or the "W" serial command.  
**Command:** EL<cr>  
**Response:** <prompt><cr>
- +P** Enable the PULSE mode  
Enables pulsing of the RF output, per the parameters specified in the programming menu or by the serial commands "D", "HT", "LP", and "HP"  
**Command:** +P<cr>  
**Response:** <prompt><cr>
- P** Disable the PULSE mode  
Disables pulsing of the RF output  
**Command:** -P<cr>  
**Response:** <prompt><cr>
- G** Enable the RF Output  
**Command:** G<cr>

- Response:** <prompt><cr>
- S Disable the RF Output  
**Command:** S<cr>  
**Response:** <prompt><cr>
- W Set the Power Setpoint  
**Command:** XXXX\_W<cr>  
 Where XXXX is the desired setpoint, in 1-Watt increments, 1 to 4 digits.  
**Response:** <prompt><cr>
- V Set the Voltage Setpoint  
**Command:** XXXX\_V<cr>  
 Where XXXX is the desired Voltage setpoint, in 1-Volt increments, 1 to 4 digits.  
**Response:** <prompt><cr>
- D Set the Process Pulse Duty Cycle  
**Command:** XXX\_D<cr>  
 Where XXX is the process pulse duty cycle, 1% to 100%, in 1% increments. 1 to 3 digits.  
**Response:** <prompt><cr>
- HT Set the Process Pulse high time  
**Command:** XXXX\_HT<cr>  
 Where XXXX is the process pulse high time, in milliseconds. 1 to 4 digits.  
**Response:** <prompt><cr>
- LP Set the Process Pulse Low Power Setpoint  
**Command:** XXXX\_LP<cr>  
 Where XXXX is the process pulse low power setpoint, in Watts. 1 to 4 digits.  
**Response:** <prompt><cr>
- HP Set the Process Pulse High Power Setpoint  
**Command:** XXXX\_HP<cr>  
 Where XXXX is the process pulse high power setpoint, in Watts. 1 to 4 digits.  
**Response:** <prompt><cr>
- ECHO Enable ECHO mode  
 Response to commands includes the <prompt> plus the command string sent to the unit, terminated with <cr>.  
**Command:** ECHO<cr>  
**Response:** <prompt><cr>

NOECHO            Disable ECHO mode  
                     Suppresses the echo of commands.  
                     Response for accepted (acknowledged) commands is <prompt><cr>.  
                     Response for invalid commands is N<cr>  
**Command:** NOECHO<cr>  
**Response:** <prompt><cr>



SERIAL COMMAND REFERENCE CHART

NOTES: The underscore character ( \_ ) indicates a space  
 <crlf> indicates carriage return - line feed terminator  
 <cr> indicates carriage return terminator.  
 Prompt character is the greater-than (>) symbol  
 The letter "X" indicates a variable character.  
 Response to all invalid commands: "N<cr>"  
 Responses shown in the chart below assume ECHO mode is *disabled*.

To	Send	Description/Comment
Query Status	Q<cr>	Returns status in the form of a mapped string, terminated with <cr>. See Serial Command details for string mapping information.
Query the Control Voltage	V?<cr>	Returns the Control Voltage, with scaling and probe attenuation factors applied. Response: -XXXX<cr> (Negative polarity is assumed) Note: Because the R301 only has one (1) External FEEDBACK input, this command is identical to the "0" command.
Query Power Leveling Mode	LVL?<cr>	Returns the current power leveling mode: Response: 0<cr> for Forward Power Leveling 1<cr> for Load (net) Power Leveling.
Query the DC Bias Voltage	0?<cr>	Returns the developed DC Bias Voltage, with scaling and probe attenuation factors applied. Response: -XXXX<cr> (Negative polarity is assumed) Note: Because the R301 only has one (1) External FEEDBACK input, this command is identical to the "V" command.
Assert SERIAL control mode	***<cr>	Sets the serial interface as the command (control) source. Response: <prompt> <cr>

To	Send	Description/Comment
Select VOLTAGE CONTROL mode	DR<cr>	Sets the Analog Interface connector FEEDBACK signal as the feedback source for regulating the RF output level. Response: <prompt><cr>
Select POWER CONTROL mode	IR<cr>	Sets the unit's internal power sensor as the feedback source for regulating the RF output level. Response: <prompt><cr>
Select FORWARD POWER leveling	DL<cr>	Regulates the RF output level based solely on the forward power feedback signal. Response: <prompt><cr>
Select LOAD POWER leveling	EL<cr>	Regulates the RF output power based on the net power delivered to the load. (forward power – reflected power = net power) Response: <prompt><cr>
Enable PULSE mode	+P<cr>	Enables Process Pulsing Response: <prompt><cr>
Disable PULSE mode	-P<cr>	Disables Process Pulsing Response: <prompt><cr>
Enable RF Output	G<cr>	Enable the RF Output Response: <prompt><cr>
Disable RF Output	S<cr>	Disable the RF Output Response: <prompt><cr>
Set the Power Setpoint	XXXX_W<cr>	XXXX is the desired power output, in Watts. 1 to 4 digits. Response: <prompt><cr>
Set the Voltage Setpoint	XXXX_V<cr>	XXXX is the desired output, in Volts. 1 to 4 digits. Response: <prompt><cr>
Set the Process Pulse duty cycle	XXX_D<cr>	XXX is the process pulse duty cycle, 1 to 100%, in 1 % increments. 1 to 3 digits. Response: <prompt><cr>
Set the Process Pulse high time	XXXX_HT<cr>	XXXX is the process pulse high time, in milliseconds. 1 to 4 digits.

To	Send	Description/Comment
		Response: <prompt><cr>
Set the Process Pulse Low Power Setpoint	XXXX_LP<cr>	XXXX is the process pulse low power setpoint, in Watts. 1 to 4 digits. Response: <prompt><cr>
Set the Process Pulse High Power Setpoint	XXXX_HP<cr>	XXXX is the process pulse high power setpoint, in Watts. 1 to 4 digits. Response: <prompt><cr>
Enable ECHO mode	ECHO<cr>	Response to commands includes the <prompt> plus the command string sent to the unit, terminated with <cr>. Response: <prompt><cr>
Disable ECHO mode	NOECHO<cr>	Suppresses the echo of commands. Response for accepted (acknowledged) commands is <prompt><cr>. Response for invalid commands is N<cr> Response: <prompt><cr>

## Configuring Programmable Parameters

### Navigating the Programming Menu

TO ENTER the programming mode, press the “PGM” button (Program/Run button – item 1) on the front panel. The legend above the button will change from “PGM” to “RUN”.

TO EXIT the programming mode, press the “RUN” button (Program/Run button – item 1) on the front panel. The legend above the button will change from “RUN” to “PGM”.

Pressing the “DOWN” button (item 2) moves down the programming menu levels.

Pressing the “UP” button (item 3) moves up the programming menu levels.

Pressing either the “UP” or “DOWN” buttons saves the programmable parameter. Pressing the “ENT” button (item 4) also saves the programmable parameter. The programmable parameters are saved in the R301 RF Power Supply's memory and are recalled upon power-on

### PROGRAMABLE PARAMETER REFERENCE CHART:

Programmable parameters intended for use by equipment operators are listed below. Asterisk (\*) indicates factory default setting.

LEVEL	PARAMETER	DISPLAY LINE 3	OPTION
1	Control Source Note: Setting the control source to Serial Control allows scrolling and setting of serial parameters (Levels 1a through 1B)	PANEL CONTROL ANALOG CONTROL SERIAL CONTROL	PANEL* ANALOG SERIAL
1a	Serial Interface Protocol	RS232	RS232
1b	Serial Baud Rate	XXXXX BAUD	19200* 9600
2	Pulse Mode Note: Setting Pulse Mode to enabled allows scrolling/setting of pulse parameters (Levels 2a through 2b)	PULSE MODE ENABLED PULSE MODE DISABLED	ENABLED DISABLED*
2a	Pulse Frequency	FREQUENCY XXXX Hz	0 Hz to 20,000 Hz
2b	Pulse Duty Cycle	DUTY CYCLE XXX %	0% to 100%
3	Leveling Source Select	POWER CONTROL VOLTAGE CONTROL	Internal Power Sensor*, External Feedback Voltage
4	Analog Voltage Range Select	RANGE 5V F.S. RANGE 10V F.S.	5VDC* 10VDC
5	Power Leveling Select	FWD POWER LEVELING LOAD POWER LEVELING	Forward Power* Load (Net) Power

**R301 RF POWER SUPPLY OPERATOR'S MANUAL**

<b>LEVEL</b>	<b>PARAMETER</b>	<b>DISPLAY LINE 3</b>	<b>OPTION</b>
6	Output Power Range Select	HIGH RANGE LOW RANGE	0-300W Output* 0-30W Output
7	Exciter Mode (Frequency Source) Select	EXCITER- MASTER EXCITER- SLAVE	Internal Source* External CEX Input
8	Maximum Output Power	ENTER MAX POWER XXXXW	1-300 Watts (Default: 300 Watts)
9	Voltage Feedback Probe Attenuation Factor	ENT PROBE ATTEN XXXX	0 to 9999:1 (Default: 200:1)
10	Reflected Power Alarm	REF PWR ALARM XXXW	1 to 300 Watts (Default: 150 Watts)
11	Power Control Gain	POWER CONT GAIN XXX%	0% to 100% (Default: 100%)
12	DC Voltage Control Gain	DCV CONT GAIN XXX%	0% to 100% (Default: 100)
13	Matching Network Preset Mode	ENABLE MATCH PRE INV ENABLE MATCH PRESET DISABLE MATCH PRESET	ENABLE INVERTED ENABLE DISABLE*
14	Load Capacitor Preset Position	LOAD PRESET XXX %	0% to 100% (Default is 50%)
15	Tune Capacitor Preset Position	TUNE PRESET XXX %	0% to 100% (Default is 50%)

PROGRAMMABLE PARAMETER DETAILS:

Level	Parameter Detail
1	<p><b>Control Source:</b> Selects the interface used as the control source for the R301 RF power supply.</p> <p><b>Panel Control</b>            Selects the front panel keypad as the control source. RF ON/OFF and power setpoint commands from the analog interface are ignored. Serial interface commands, with the exception of the "SERIAL" command, are ignored. (Factory Default Setting). Line 2 of the front panel display shows "PANEL" as the control source.</p> <p><b>Analog Control</b>        Selects the analog interface as the control source. Front panel RF ON and power setpoint commands are ignored. Serial commands, with the exception of the "SERIAL" command, are ignored. <u>Note:</u> The front panel RF ON/OFF button can disable the RF output. Line 2 of the front panel display shows "ANALOG" as the control source.</p> <p><b>Serial Control</b>         Selects the serial interface as the control source. Front panel RF ON and power setpoint commands are ignored. RF ON/OFF and power setpoint commands from the analog interface are ignored. <u>Note:</u> The front panel RF ON/OFF button can disable the RF output. Selecting Serial Control enables access to levels 1a and 1b. Line 2 of the front panel display shows "SERIAL" as the control source.</p>
1a	<p><b>Serial Interface Protocol:</b> Selects RS-232 (Factory Default Setting), RS-422, or RS-485 serial protocol</p>
1b	<p><b>Serial Baud Rate:</b> Selects 19200 Baud (Factory Default Setting) or 9600 Baud. Other serial communication parameters are not configurable. Parity: None; Data bits: 8; Stop Bits: 1; Handshaking: None</p>
2	<p><b>Pulse Mode:</b> Enables or Disables (Factory Default Setting) the R301's internal pulsing of the RF output. When RF output is enabled, the RF output is pulsed between 0 watts and the power setpoint at the pulse parameters specified in levels 2a and 2b. Line 2 of the front panel display shows "PLS" as the power control mode. Enabling Pulse Mode allows access to levels 2a and 2b.</p>
2a	<p><b>Pulse Frequency:</b> Sets the pulse repetition rate. The rate can be varied from 0 Hz to 20,000Hz, in 1-Hz increments. Factory default setting is 1000Hz.</p>
2b	<p><b>Pulse Duty Cycle:</b> Sets the "ON" duration of the RF output pulse. The "ON" duration can be varied from 1% to 100%, in 1% increments. Factory default setting is 50%.</p>
3	<p><b>Leveling Source Select:</b> Selects the feedback source used to regulate the RF output level. Related menu level: 5</p>

Level	Parameter Detail	
	POWER CONTROL:	<p>Uses the R301's internal power sensor as the feedback source for regulating the RF output level.</p> <p>Line 1 of the front panel display indicates forward power setpoint, in Watts, when the RF output is off, indicates Forward or Load power when the RF output is enabled.</p> <p>Line 2 of the front panel display indicates "PWR" when POWER CONTROL is selected.</p> <p>(Factory Default Setting)</p>
	VOLTAGE CONTROL:	<p>Uses the analog interface connector's FEEDBACK signal (pins 12 and 24) as the feedback source for regulating the RF output level.</p> <p>Line 1 of the front panel display indicates the voltage setpoint, when the RF output is off, indicates Probe Voltage when the RF output is enabled.</p> <p>Line 2 of the front panel display indicates "VLT" when VOLTAGE CONTROL is selected.</p> <p>Related menu levels: 4, 9</p>
4	Analog Voltage Range Select:	<p>Selects the Full-Scale voltage for the analog interface's SETPOINT and FEEDBACK inputs, and the analog interface's FWD MON (Forward Power monitor) and REFP MON (Reflected Power monitor) outputs.</p>
	RANGE 5V F.S.	<p>Sets +5.0VDC as the full-scale voltage.</p> <p>(Factory Default Setting)</p>
	RANGE 10V F.S.	<p>Sets +10.0VDC as the full-scale voltage.</p>
5	Power Leveling Select:	<p>Selects the method used to regulate the unit's RF output power when Leveling Source Select (menu level 3) is set to POWER CONTROL.</p>
	FWD POWER LEVELING	<p>Regulates the RF output power based solely on the forward power feedback signal. The front panel display and the analog interface's FWD MON (forward power monitor) signal indicate the amount of forward power delivered to the load. (Factory Default Setting)</p>
	LOAD POWER LEVELING	<p>Regulates the RF output power based on the net power delivered to the load. (forward power – reflected power = net power). The front panel display and the analog interface's FWD MON (forward power monitor) signal indicate the amount of net power delivered to the load.</p>
6	Output Power Range Select:	<p>HIGH RANGE sets the unit's output power range from 0% to 100% of the unit's rated power output (300 Watts), with standard power setpoint and power metering resolution. (Factory Default Setting)</p> <p>LOW RANGE sets the unit's output power range from 0% to 10% of the unit's rated power output (30 Watts), with enhanced power setpoint and power metering resolution.)</p>

Level    Parameter Detail

- 7    Exciter Mode (Frequency Source) Select:  
       EXCITER- MASTER: The unit uses its internal frequency source to generate the RF output signal. In “master” mode, the internal frequency source is available at the CEX OUT connector on the rear panel. (Factory Default Setting)  
       EXCITER- SLAVE: The unit uses the rear panel CEX IN signal as the frequency source for the RF output signal. “Slave” Mode is used in systems with multiple RF power supplies; with one RF power supply as the master and the other power supplies operating as “slaves”. This configuration is used to keep the power supplies synchronized, thus preventing or minimizing RF circulating currents within the processing system. In “slave” mode, the CEX IN signal is routed to the rear panel CEX OUT connector.
- 8    Maximum Output Power:  
       Allows the user limit the maximum RF output power. Limit is adjustable between 1 and 300 Watts, in 1-Watt increments. When the output power setpoint is equal to the MAX POWER value, “MAX” is indicated on the front panel display, line 2, right-hand side.  
       Factory default value is 300 Watts.
- 9    Voltage Feedback Probe Attenuation Factor:  
       Used when regulating the unit’s RF output with an external feedback signal. Setting the attenuation factor to match the external system’s probe attenuation factor allows the R301 RF power supply to directly display the feedback signal in Volts.  
       External feedback voltages are derived from the processing system and can range from tens of Volts to thousands of Volts. Because it is not practical or safe to use high-voltage control signals, and the R301’s maximum external feedback input voltage is 10VDC, an attenuator probe is used in most systems.  
       The external system’s attenuator probe is calibrated, and the calibration is specified as a ratio. Adjust the R301’s voltage feedback probe attenuation factor to match the system’s voltage probe attenuation ratio.  
       Related menu levels: 3, 4  
       Factory Default value is 200:1
- 10    Reflected Power Alarm:  
       Allows the user to set a threshold for indicating a high-reflected power condition. Adjustable between 1 and 300 Watts, in 1-Watt increments.  
       When the alarm threshold is met or exceeded, “REF” is indicated on line 2 of the front panel display and the status of the analog interface connector RFENABLED\* signal (pin 8) is changed from a TTL logic low (0) state to a TTL logic high (1) state.  
       Units built on or after August 1, 2004 are shipped with the alarm threshold set to 150 Watts (disabled). Units built prior to August 1, 2004 were shipped with the alarm threshold set to 35 Watts.  
       To enable changing of the RFENABLED\* signal status, set the alarm threshold lower than the unit’s maximum reflected power limit (50 Watts)  
       Factory default value is 150 Watts (disabled).
- 11    Power Control Gain  
       Factory default setting is 100%



Level	Parameter Detail
12	<p>DC Voltage Control Gain</p> <p>Factory default setting is 100%</p>
13	<p>Matching Network Preset Mode:</p> <p>Enables or disables the Matching Network Preset feature and configures the behavior of the analog interface connector RFENABLED* signal (pin 8) when the Matching Network Preset feature is enabled.</p> <p>ENABLE MATCH PRE INV      When the RF output is disabled, the matching network preset position voltages are present on the analog interface connector's FWD MON and REFP MON signal pins.</p> <p>   Analog interface connector RFENABLED* signal (pin 8) outputs a TTL logic high (1) state when the RF output is enabled and the reflected power threshold alarm has not been exceeded.</p> <p>   Analog interface connector RFENABLED* signal (pin 8) outputs a TTL logic low (0) state when the RF output is disabled or when the reflected power threshold alarm has been exceeded.</p> <p>ENABLE MATCH PRESET      When the RF output is disabled, the matching network preset position voltages are present on the analog interface connector's FWD MON and REFP MON signal pins.</p> <p>   Analog interface connector RFENABLED* signal (pin 8) outputs a TTL logic low (0) state when the RF output is enabled and the reflected power threshold alarm has not been exceeded.</p> <p>   Analog interface connector RFENABLED* signal (pin 8) outputs a TTL logic high (1) state when the RF output is disabled or when the reflected power threshold alarm has been exceeded.</p> <p>DISABLE MATCH PRESET      Disables Matching Network Preset feature (Factory default setting)</p> <p><u>Note:</u> This feature is designed for use with the Seren IPS Inc. MC2 matching network controller and AT-Series automatic matching networks. The MC2 controller, AT-Series matching networks, and interface cabling are not supplied with the R301 product and must be purchased separately.</p> <p>Related menu items: 14, 15</p>
14	<p>Load Capacitor Preset Position:</p> <p>Sets the Load Capacitor preset position voltage output for an external matching network. Adjustable from 0% (0.0VDC output) to 100% (+5.0VDC), in 1% (50mV) increments.</p> <p>With Matching Network Preset Mode enabled and the RF output disabled, the Load Capacitor preset position voltage (0 to +5.0VDC) is present at the analog interface connector's REFP MON (reflected power monitor) signal (pin 11).</p> <p><u>Note:</u> this feature designed for use with the Seren IPS Inc. MC2 matching network controller and AT-Series automatic matching networks.</p> <p>Related menu item: 13</p>

Level Parameter Detail

Factory default setting is 50%

15 Tune Capacitor Preset Position:

Sets the Tune Capacitor preset position voltage output for an external matching network.

Adjustable from 0% (0.0VDC output) to 100% (+5.0VDC), in 1% (50mV) increments.

With Matching Network Preset Mode enabled and the RF output disabled, the Tune Capacitor preset position voltage (0 to +5.0VDC) is present at the analog interface connector's FWD MON (forward power monitor) signal (pin 10).

Note: this feature designed for use with the Seren IPS Inc. MC2 matching network controller and AT-Series automatic matching networks.

Related menu item: 13

Factory default setting is 50%

**Rear Panel Controls and Connections**

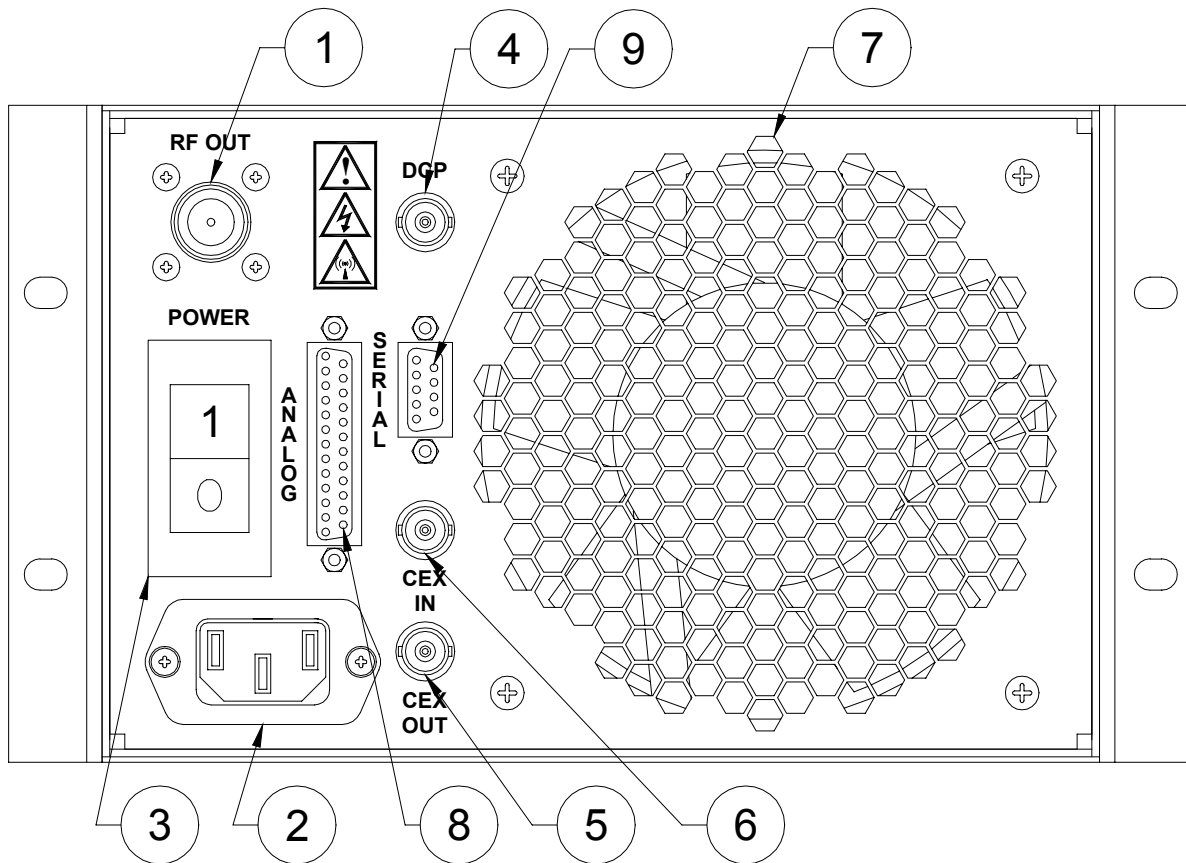

**1. RF Output**

Type “N” female RF connector. Connect a 50-Ohm coaxial cable from the RF Output connector to a 50-Ohm load (50-Ohm 300 Watt resistive load, impedance matching network, impedance matching transformer, plasma chamber, or other processing apparatus). The center pin of the connector is RF “hot”, connector shell is RF return.

**2. Power Inlet**

Power Inlet Connector: IEC320 type male, filtered.  
 Mating Cord Connector: IEC320-C13.

**CAUTION: UNLESS OTHERWISE SPECIFIED, THE R301 RF POWER SUPPLY IS SHIPPED FROM THE FACTORY CONFIGURED FOR 115 VOLT OPERATION. CHECK YOUR MAINS VOLTAGE AND THE LINE VOLTAGE PRINTED ON THE RATINGS PLATE OR CONSULT A QUALIFIED ELECTRICIAN BEFORE CONNECTING THE R301 RF POWER SUPPLY TO MAINS POWER. CONNECTING TO THE WRONG MAINS VOLTAGE MAY DAMAGE THE R301 RF POWER SUPPLY AND VOID THE WARRANTY.**

Connect the supplied power cord to the power inlet and connect to mains power.



If the power cord is lost or damaged, replacement cords are available from Seren IPS Inc. or can be purchased locally. When purchasing a power cord from a local vendor, ensure the replacement cord is of the same wire gauge, current handling capacity, and voltage rating.

3. Mains Circuit Breaker:

Set to the “1” position to enable, set to the “0” position to disable. To reset the circuit breaker, set the handle to the “0” position, then to the “1” position

4. DCP Connector (optional)

Voltage Probe Inverter Input. Analog input, 0 to –10VDC input range.

Connector: Type BNC Female

Input Impedance: 100K Ohm

Option. Permits the R301 to use a negative polarity voltage probe signal from a passive probe (such as an MM-Series or PM-Series matching network) for external RF output regulation feedback (voltage control). Connect a negative polarity probe signal to the DCP connector and connect Analog Interface connector pin 25 (INVPROBE output) to Analog Interface connector pin 24 (FEEDBACK input).

5. CEX OUT Connector

Common EXciter output: 5 to 8V Peak-to-Peak, 13.56MHz.

Connector: Type BNC Female

In “Master” mode, the common exciter output signal is present at all times regardless of the RF output state. In “slave” mode, the common exciter output signal is present when there is a signal present at the CEX IN connector.

In “Master” mode, the common exciter output frequency is the same as the programmed frequency. In “Slave” mode, the common exciter output frequency is the same as the signal at the CEX IN connector.

6. CEX IN Connector

Common Exciter input; 3 to 8V Peak-to-Peak sine wave, 13.56MHz.

Connector: Type BNC Female

When in Slave mode, the R301 RF Power Supply uses the common exciter input as its frequency source.

7. Fan Exhaust

Keep fan exhaust free of obstructions, dust and dirt.



When the R301 RF Power Supply is mounted in an enclosure or equipment rack, ensure there is an adequate air intake and hot air exhaust. Operating the R301 at elevated temperatures or reduced airflow for long periods of time may degrade its reliability and/or void the warranty.

8. Analog Interface Connector

The analog interface connector is located on the rear panel of the R301 Radio Frequency Power Supply. Connector type: 25-pin female “D” sub-miniature. Control and status signals for the RF Power Supply are available on this connector. See the table below for descriptions of the interface connector signals.

**Note:** GND, FWDRET, REFRET, FBRET, and SETRET must be referenced at the user’s system or the unit will not operate properly

The RF Power Supply responds to input from the Analog interface when ANALOG control has been selected. The Mains Interlock (pins 1 and 14) and External Interlock (pins 2 and 15) are active regardless of control method selected.

Asterisk (\*) denotes an active-low signal

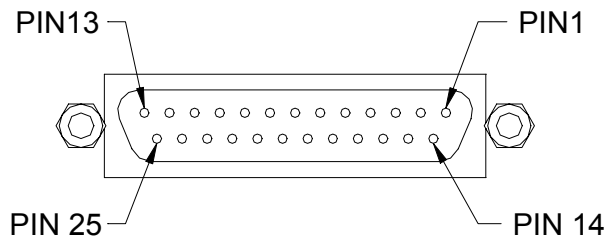

ANALOG INTERFACE

PIN	SIGNAL NAME	DESCRIPTION
1	MAINS INTLK 1	AC Mains Power Interlock. 24VAC current loop, 100 mA maximum current. A contact closure between pin 1 and pin 14 is required to allow AC mains power to engage. An open circuit between pin 1 and pin 14 disables AC mains power.

PIN	SIGNAL NAME	DESCRIPTION
		This signal is active in Panel, Analog, or Serial control modes
2	INTERLOCK	<p>External Interlock. TTL – compatible input, active low, with an internal pull-up resistor.</p> <p>A contact closure between pin 2 and pin 15 or a TTL “low” signal applied to pin 2 is required before RF output can be enabled.</p> <p>An open circuit or a TTL “high” signal applied to pin 2 while the RF output is enabled, will cause the RF output to turn off.</p> <p>An open circuit or a TTL “high” signal applied to pin 2 while the RF output is off, will prevent the RF output from being enabled.</p> <p>This signal is active in Panel, Analog, or Serial control modes</p>
3	RFON*	<p>RF Output Enable/Disable. TTL – compatible input, active low, edge triggered, with an internal pull-up resistor.</p> <p>A contact closure between pin 3 and pin 16 or a TTL signal transition from “high” to “low” applied to pin 3 enables the RF output, provided Pin 2 is at TTL “low” state.</p> <p>An open circuit between pin 3 and pin 16 or a TTL signal transition from “low” to “high” applied to pin 3 disables the RF output.</p> <p>This signal is active only in “Analog” control mode.</p>
4	PWR/VLT*	<p>Power or Voltage leveling mode select. TTL – compatible input with internal pull-up resistor.</p> <p>An open circuit or TTL “high” signal applied to pin 4 selects the power supply’s internal power sensor for power regulation.</p> <p>A contact closure between pin 4 and pin 16 or a TTL “low” signal applied to pin 4 selects forward power regulation based on an external feedback signal (FEEDBACK signal - Pins 12 and 24).</p> <p>Refer to the controls section of the operator’s manual for detailed instructions on how to configure and use this mode.</p> <p>This signal is active only in “Analog” control mode.</p>
5	SLAVE*	<p>Selects internal oscillator/exciter or external oscillator/exciter (Slave Mode) as frequency source operation. TTL – compatible input with an internal pull-up resistor.</p> <p>A contact closure between pin 5 and pin 17 or applying a TTL “low” signal to pin 5 selects external frequency source (Slave Mode) operation. The external frequency source is connected to the “CEX IN” connector on the rear panel.</p> <p>An open circuit or TTL “high” applied to pin 5 selects the power supply’s internal oscillator/exciter as the frequency source.</p> <p>This signal is active only in “Analog” control mode.</p>
6	GATEN*	<p>Selects Continuous Wave (CW) or Pulse Operation. TTL – compatible input with an internal pull-up resistor.</p> <p>A contact closure between pin 6 and pin 18 or applying a TTL “low” signal to pin 6 selects pulse operation. Apply the external pulse train to Pin 7.</p> <p>Applying a logic level high to this pin or allowing this pin to float selects continuous wave (CW) operation.</p>

PIN	SIGNAL NAME	DESCRIPTION
7	GATE	<p>External Pulse Train input. Toggles output power between setpoint value and 0 Watts. TTL - compatible input with internal pull-up resistor.</p> <p>An open circuit or TTL "high" signal applied to pin 7 holds the RF output to the setpoint level.</p> <p>A contact closure between pin 7 and pin 21 or a TTL "low" signal applied to pin 7 switches the RF output power to 0 Watts.</p> <p>Active when pin 6 (GATEN*) is in a TTL "low" state.</p>
8	RFENABLED*	<p>RF output status signal. Active low, open collector output. 12VDC, 15mA maximum current sink, 150mW maximum power dissipation.</p> <p>Signal output is 0V (low) for an RF on condition; signal output is "open" for an RF off condition.</p> <p>The RFENABLED* signal can also indicate the presence of excessive reflected power by changing from a "low" state to a "high" state when the RF output is enabled. Refer to "Reflected Power Alarm" in the Programmable Parameters section for details.</p> <p>The RFENABLED* output signal may also be used to pre-position Seren IPS Inc. AT-Series Matching Networks. Refer to "Matching Network Preset Mode", "Tune Capacitor Preset Position", and "Load Capacitor Preset Position" in the Programmable Parameters section.</p> <p>Use pin 21 for a reference return.</p>
9	GND	<p>Internally connected to chassis ground. Connect to system controller common or ground reference.</p>
10	FWD MON	<p>Forward power monitor output signal. Analog output, selectable 0 to +5VDC or 0 to +10VDC range via front panel controls.</p> <p>Output is linearly proportional to 0 to 300 Watts of forward power.</p> <p>Output scaling is 5.0VDC at 300 Watts (16.66mV/Watt) or 10.0VDC at 300 Watts (33.33mV/Watt), depending on output range selected. (Default scaling)</p> <p>The forward power monitor output signal may also be used to pre-position Seren IPS Inc. AT-Series Matching Networks. Refer to "Matching Network Preset Mode", "Tune Capacitor Preset Position", and "Load Capacitor Preset Position" in the Programmable Parameters section.</p> <p>Measure monitor voltage with respect to pin 22 (FWDRET).</p>
11	REFP MON	<p>Reflected power monitor output signal. Analog output, selectable 0 to +5VDC or 0 to +10VDC range via front panel controls.</p> <p>Output is linearly proportional to 0 to 100 Watts of forward power.</p> <p>Output scaling is 5.0VDC at 100 Watts (50mV/Watt) or 10.0VDC at 100 Watts (100mV/Watt), depending on output range selected. (Default scaling)</p> <p>The reflected power monitor output signal may also be used to</p>

PIN	SIGNAL NAME	DESCRIPTION
		<p>pre-position Seren IPS Inc. AT-Series Matching Networks. Refer to "Matching Network Preset Mode", "Tune Capacitor Preset Position", and "Load Capacitor Preset Position" in the Programmable Parameters section.</p> <p>Measure monitor voltage with respect to pin 23 (REFRET).</p>
12	FEEDBACK	<p>External feedback voltage signal. Analog input, 0 to +10.0VDC . Internally connected to pin 24.</p> <p>Use pin 16, 17, 18, or 21 (GNDI) for return reference.</p> <p>The RF Power Supply will automatically adjust its output power to maintain the FEEDBACK signal's magnitude at the same level as the SETPOINT signal magnitude. The PROBE voltage will be displayed on the front panel. The PROBE attenuation factor can be configured from the front panel.</p> <p>The external feedback signal is derived from a voltage probe (RF or DC) located elsewhere in the plasma or process system. Refer to the controls section for detailed instructions on how to configure and use this mode.</p> <p>Note: The feedback voltage polarity must match the setpoint input's (pin 13) polarity for proper operation of voltage control mode.</p>
13	SETPOINT	<p>Power or Voltage setpoint input. Analog, high-impedance, differential input with selectable 0 to +5.0VDC or 0 to +10.0VDC range via front panel controls.</p> <p>Refer to the controls section of the operator's manual for detailed instructions on how to configure and use this mode</p> <p>NOTE: Ground return (GNDI, pin 16,17,18, or 21) <b><i>MUST</i></b> be referenced to common or ground at the setpoint voltage source (system controller) or the RF output power will behave erratically.</p> <p>In Power Control mode, sensitivity is 300 Watts at 5.0VDC (16.66mV per Watt) or 300 Watts at 10.0VDC (33.33mV per Watt) depending on range selected.</p> <p>NOTE: Feedback voltage range and polarity must match setpoint voltage range and polarity for proper operation in voltage control mode.</p> <p>Pin 13 is the positive (+) input of the differential setpoint amplifier.</p> <p>Active only in ANALOG control mode.</p>
14	MAINS INTLK 2	<p>A contact closure between pin 1 and pin 14 is required to allow AC mains power to engage. An open circuit between pin 1 and pin 14 disables AC mains power. 24VAC current loop, 100 mA maximum current</p> <p>This signal is active in Panel, Analog, or Serial control modes</p>
15	INTERLOCK-RTN	Ground return for External Interlock (pin 2)
16	GNDI	Ground return for pins 3,4,5,6,7,8,13,19. Internally connected to chassis ground.
17	GNDI	Ground return for pins 3,4,5,6,7,8,13,19. Internally connected to



<b>PIN</b>	<b>SIGNAL NAME</b>	<b>DESCRIPTION</b>
		chassis ground.
18	GNDI	Ground return for pins 3,4,5,6,7,8,13,19. Internally connected to chassis ground.
19	RL-IN	Remote Limit input. Analog input, 0 to +5VDC range. Use pin 16,17,18, or 21 (GNDI) for return reference. Used in dual-bias or multiple power supply systems to fold-back the power supply's output power if reflected power is detected by another power supply in the system. Output power folds back in response to an external voltage applied to this input. Foldback threshold is factory preset at +5.00VDC (Disabled). Consult factory for assistance.
20	RL-OUT	Remote Limit Output. Analog output, 0 to +10VDC range. Buffered, high-speed, non-linearized directional coupler reflected power signal. Return reference is pin 23. Used on dual-bias or multiple power supply systems. Consult factory for assistance.
21	GNDI	Ground return for pins 3,4,5,6,7,8,13. Internally connected to chassis ground.
22	FWDRET	Forward Power Monitor return. Analog output. For pin 10.
23	REFRET	Reflected Power Monitor/Remote Limit return. Analog output. For pins 11 and 20.
24	FEEDBACK	External feedback voltage signal. Analog input, 0 to +10.0VDC. Internally connected to pin 12. Use pin 16, 17, 18, or 21 (GNDI) for return reference. The RF Power Supply will automatically adjust its output power to maintain the FEEDBACK signal's magnitude at the same level as the SETPOINT signal magnitude. The PROBE voltage will be displayed on the front panel. The PROBE attenuation factor can be configured from the front panel. The external feedback signal is derived from a voltage probe (RF or DC) located elsewhere in the plasma or process system. Refer to the controls section for detailed instructions on how to configure and use this mode. Note: The feedback voltage polarity must match the setpoint input's (pin 13) polarity for proper operation of voltage control mode.
25	INVPROBE	Inverted Probe Output. Analog output, 0 to +10.0VDC. Inverted polarity signal derived from the rear panel "PROBE" BNC connector. Magnitude of the signal remains identical, polarity changed from negative (at the PROBE connector) to positive. Connect to pin 24 (if required) when using external feedback to regulate RF output level.

**TYPICAL INTERFACE CIRCUITS**

Figures 1 through 5 illustrate the typical circuits used in the R301 RF Power Supply's Analog Interface.

RFENABLED\* Output Circuit:

RF output status signal. Active low, open collector output. 12VDC maximum, 15mA maximum current sink, 150mW maximum power dissipation.

Signal output is closed (0V or "low") for an RF on condition; signal output is "open" for an RF off condition.

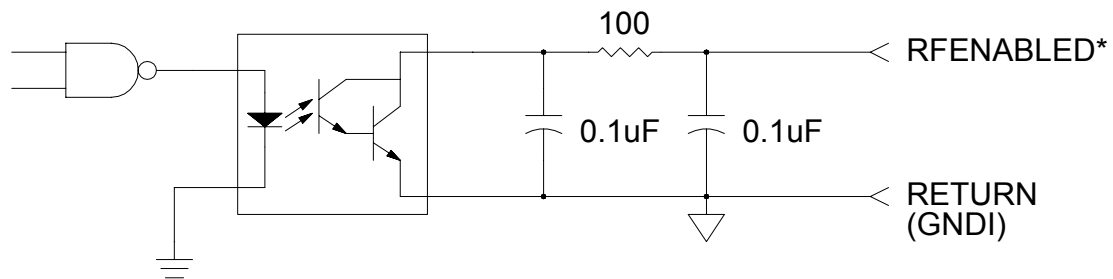

Figure 1: RFENABLED\* Circuit

TTL-Compatible Input Circuits

All TTL-Compatible logic input circuits are internally pulled up to +5VDC. Signal function and response is as described in the Analog Interface Connector pin list.

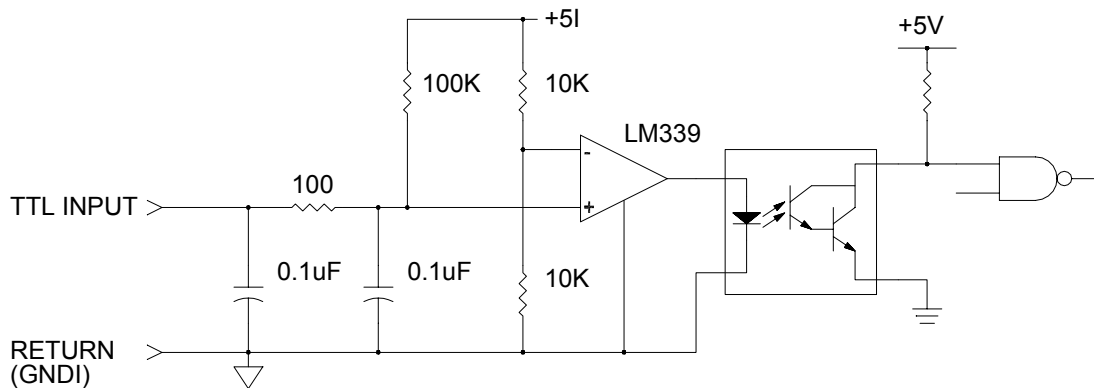

Figure 2: TTL-Compatible Input Circuits

SETPOINT Input Circuit

High-impedance, high Common-Mode Rejection Ratio, differential analog input. Input voltage range is software selectable 0 to +5.0VDC or 0 to +10.0VDC via the front panel controls. NOTE: The setpoint return signal (GNDI, pin 16, 17, 18, or 21) ***MUST*** be referenced to common or ground at the setpoint voltage source (system controller) or the RF output power will behave erratically.

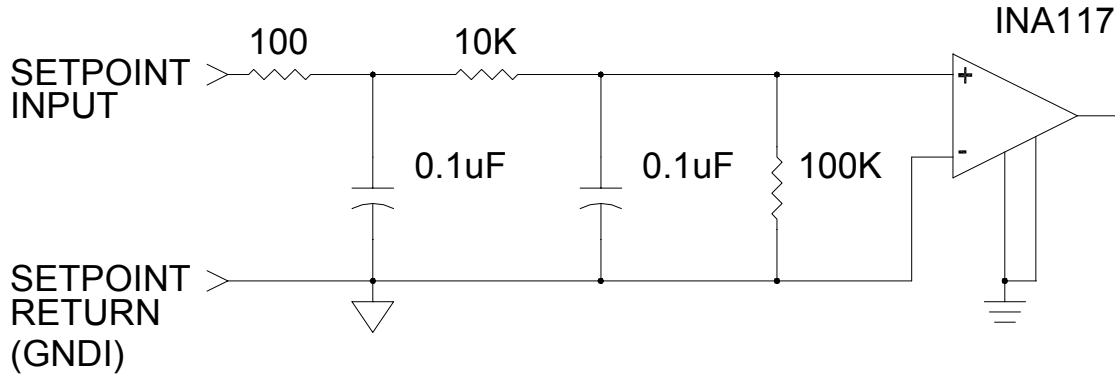

Figure 3: SETPOINT Input Circuit

FEEDBACK Input Circuit

High-impedance, high Common-Mode Rejection Ratio, differential analog input. Input voltage range is 0 to +10.0VDC. NOTE: The feedback return signal (GNDI, pin 16, 17, 18, or 21) ***MUST*** be referenced to common or ground at the feedback voltage source (Voltage Probe) or the RF output power will behave erratically.

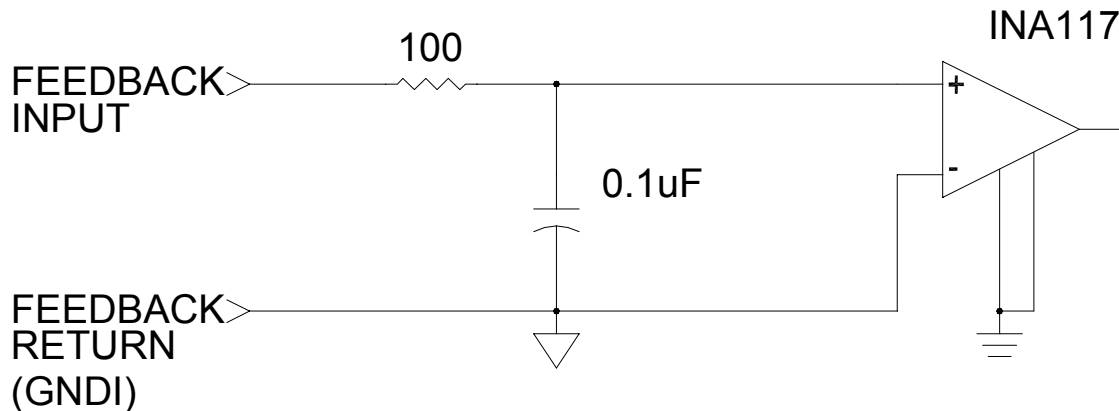

Figure 4: FEEDBACK Input Circuit

MONITOR Output Circuit

Analog output, selectable 0 to +5VDC or 0 to +10VDC range via front panel controls. Normal function is forward or reflected power monitoring, but can be configured to pre-position Seren IPS Inc. AT-Series Matching Networks. See the Programming Menu reference for additional details.

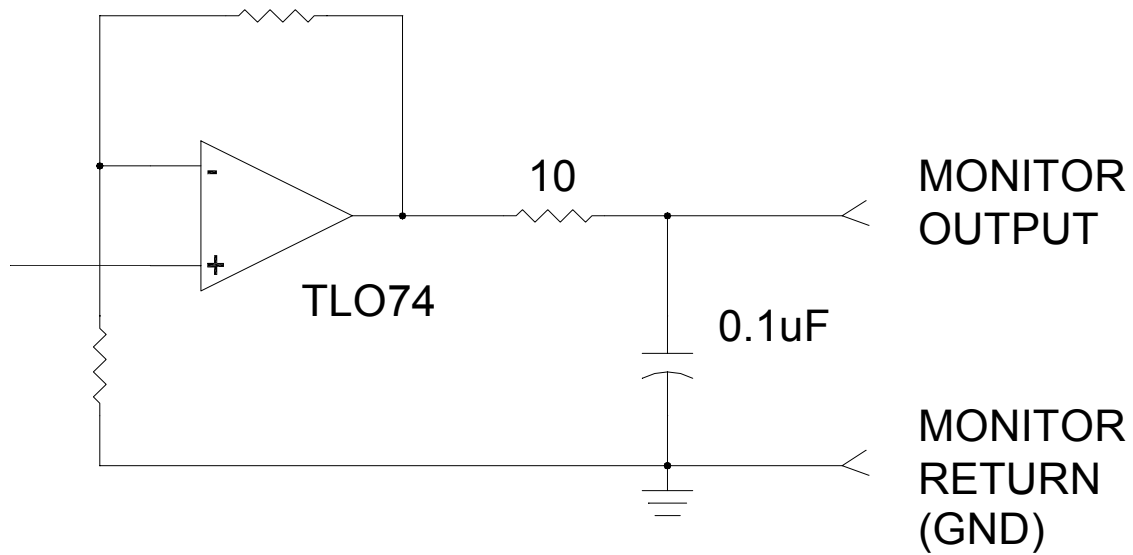

Figure 5: MONITOR Output Circuit

**9. Serial Interface Connector**

The serial interface provides remote control and monitoring of the R301 RF Power Supply via a computer. Serial interface protocol is RS-232. Baud rates are selected via the front panel.

Connector Type: 9 pin "D" female

For serial operation details, see the Serial Commands section of this manual.

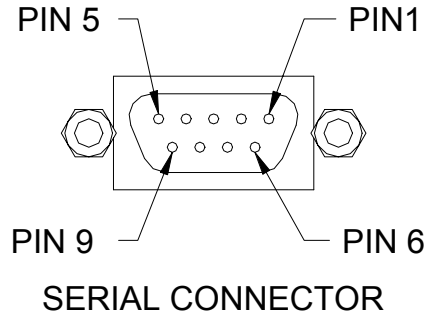

Pin	Signal	Description
1	No Connection	No Connection
2	TXB	Transmit Data
3	RXB	Receive Data
4	No Connection	No Connection
5	COMMON	Common Return (GND)
6	No Connection	No Connection
7	CTS	Clear To Send
8	RTS	Request To Send
9	COMMON	Common Return (GND)

**TYPICAL INTERFACE CONNECTIONS**

Analog Control

There are many possible analog interface wiring schemes. Basic analog interface connections are diagrammed below. Refer to the Analog Interface Connector pin list in the Rear Panel Controls and Connections section for signal details. Use shielded cable for all interconnections.

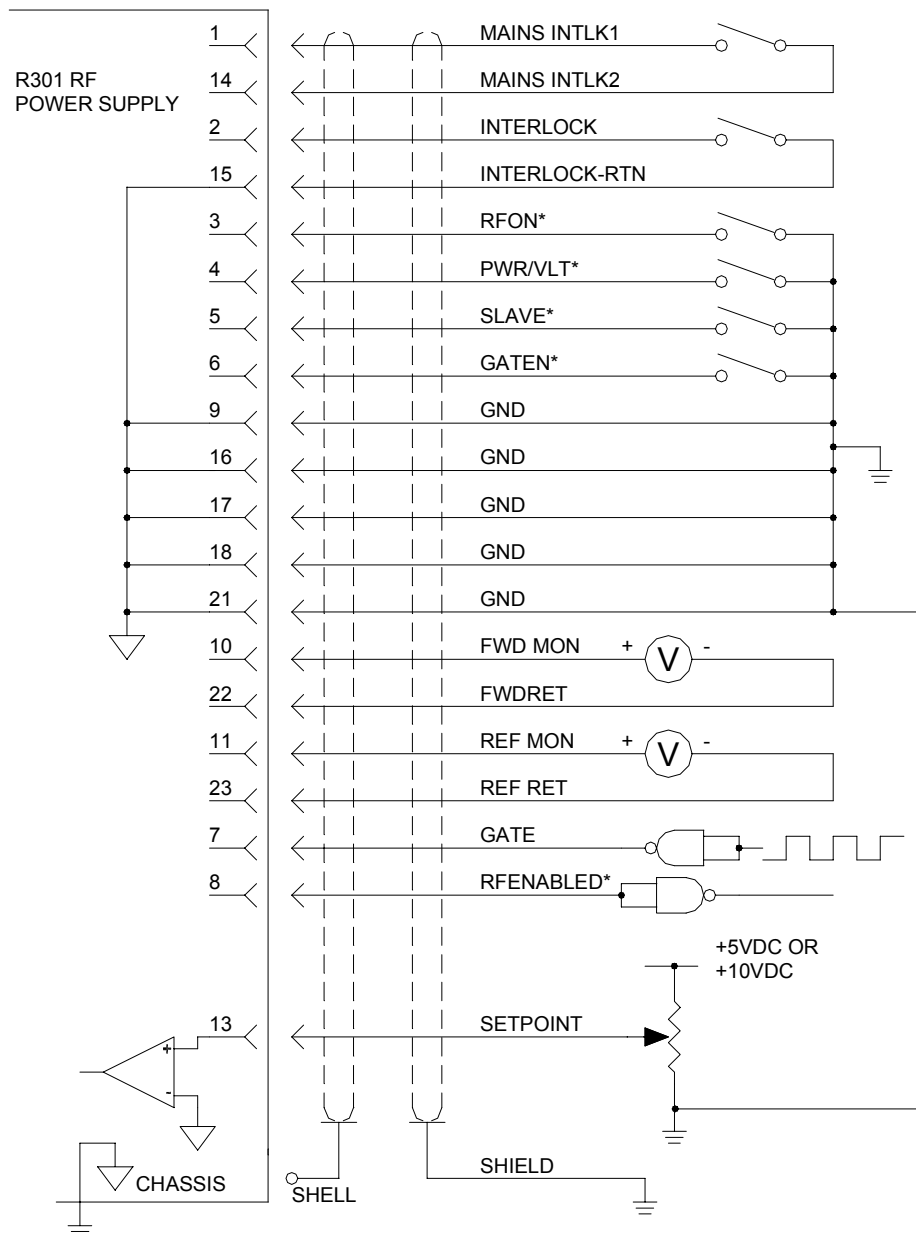

Typical Analog Interface Connections

External Feedback with Probe Inverter Option

The R301 RF power supply's external feedback input (FEEDBACK, analog interface connector pins 12 and 24) only accepts a positive (+) polarity signal. The Probe Inverter feature allows the R301 RF Power Supply to utilize a negative polarity feedback signal.

Connect the negative polarity external feedback signal to the rear panel "DCP" BNC connector and connect Analog Interface connector pin 24 to pin 25.

If desired, the inverted probe signal may also be routed to the user's system for monitoring purposes. Use analog interface connector pins 12 (FEEDBACK) and 18 (GND). Connections **must** be made with shielded cable to prevent interference to the feedback signal.

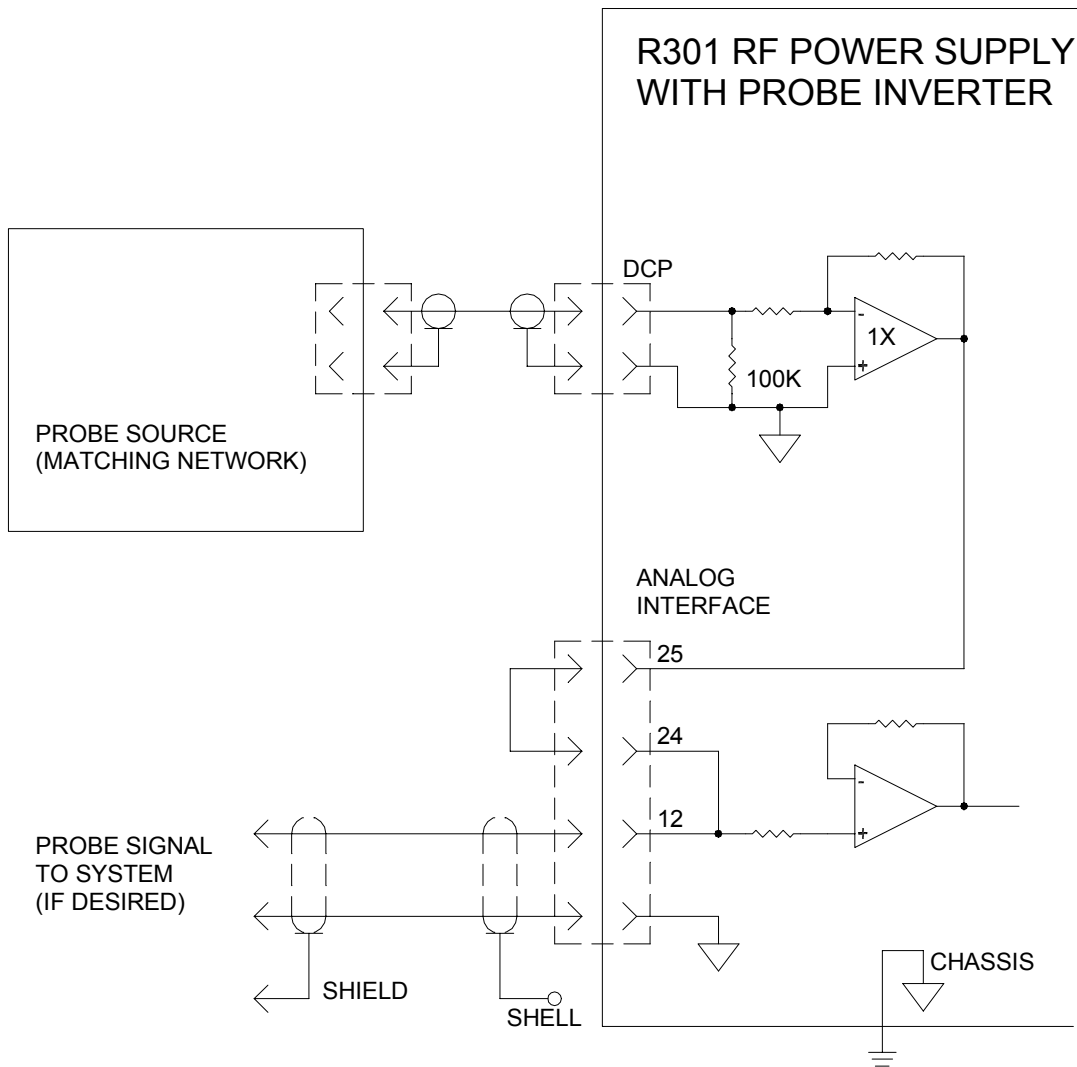

Probe Inverter Connections

External Feedback with Seren IPS AT-Series Matching Networks

External feedback is also available when using a Seren IPS Inc. AT-Series automatic impedance matching network (purchased separately). In this application, there is no connection between the R301's Analog Interface connector pins 24 and 25, and there is no connection to the R301's rear panel PROBE connector.

The external feedback signal is derived in the AT-series matching network, via a DC Probe circuit. The DC Probe's output is passed through the AT-Series control cable to the MC2 Matching Network Controller. The external feedback signal (DC Probe) may be displayed on the MC2 Controller's front panel. When used with an optional interconnect cable, connecting the MC2 Controller's "TO GENERATOR" connector the R301's Analog Interface connector, the external feedback signal (DC Probe) is routed to the R301's External Feedback input. Refer to the diagram below.

In addition, the MC2 controller can display Forward and Reflected power and can act as an interconnection hub for the user's system. For full details, refer to the MC2 Matching Network Controller Operator's Manual or contact a Seren IPS Inc. customer support technician.

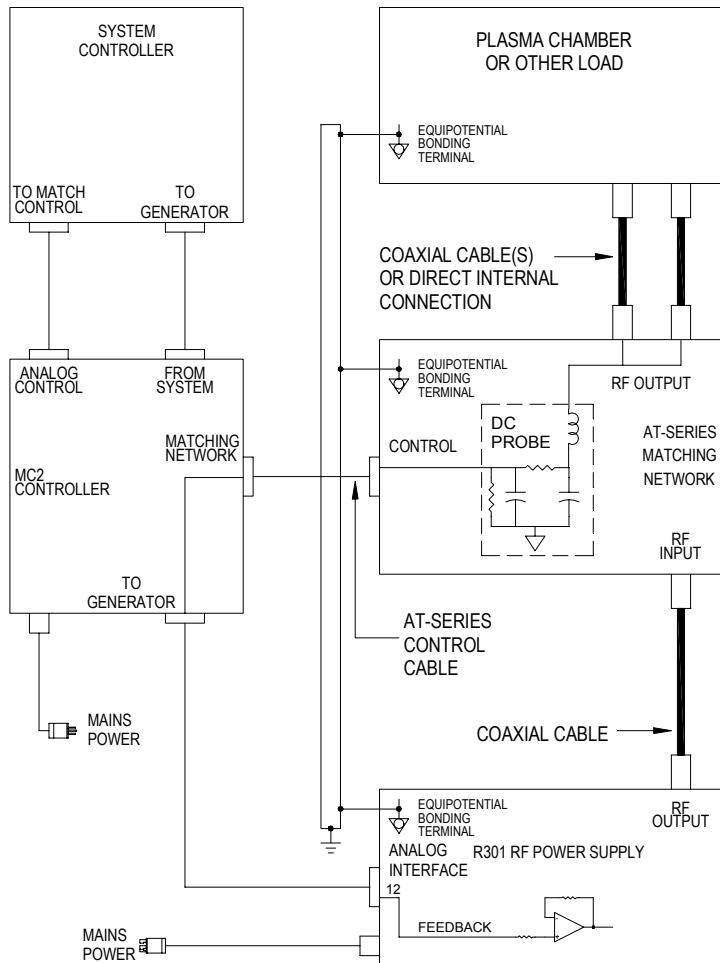

External Feedback with AT-Series Matching Network



**Typical System Configuration**

A basic plasma processing system configuration is diagrammed below. Other system configurations are possible. For assistance with system configuration issues, contact the Seren IPS Inc. customer service department or a Seren IPS Inc. service depot. Coaxial cables, control cables, matching networks, matching network controllers, and plasma system equipment are not supplied with the R301 RF Power Supply.

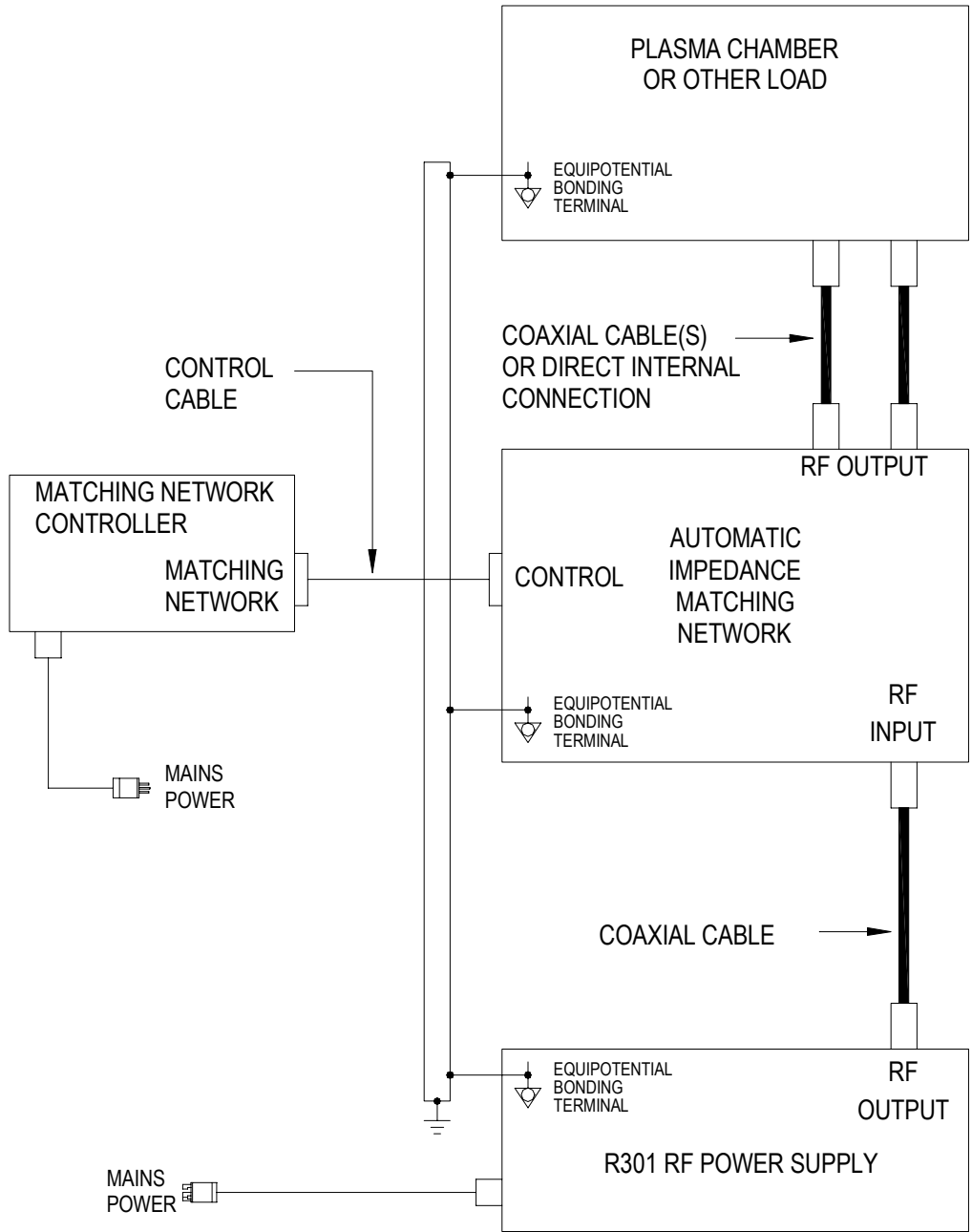

Typical Configuration - Basic Plasma Processing System

## **Maintenance**

The R301 Radio Frequency Power Supply is designed to be maintenance free. There are no user maintainable assemblies inside the unit. The R301 RF Power Supply is designed for use in a clean environment. Periodically check the air inlets and exhaust fan vents for accumulation of dust and debris. Clean the air inlets and exhaust fan with a vacuum cleaner if they appear dirty or clogged.



Restricting the air inlets, blocking the exhaust fan, or installing the R301 RF Power Supply in a dusty environment may impact the long-term reliability of the R301 RF Power Supply.

### Cleaning:

**DO NOT** clean the R301 RF Power Supply when AC Mains power is applied to the unit or when the R301 unit is connected to the AC mains. The exterior of the RF power supply may be cleaned with a soft cloth, dampened with soap and water or a mild solvent, such as alcohol. Allow time for the RF power supply to dry before re-connecting to AC Mains power.

## **Problem Solving**

### *Problem Solving Chart*

The following chart lists some conditions that may occur and the recommended solutions. Follow the suggested solutions until the problem is corrected. If the problem persists, please contact Seren IPS Inc. customer service or a Seren IPS Inc. service representative.

<b>Condition</b>	<b>Suggested Solution</b>
Front panel display does not illuminate	<p>Check the power connector – ensure it is properly seated in the AC Mains power inlet.</p> <p>Verify rear panel circuit breaker is in the “1” (on) position.</p> <p>Ensure the Analog Interface Connector is fully seated and the Analog Interface “MAINS INTLK” circuit is completed – connect pin 1 to pin 14 on the analog interface connector.</p> <p>Check the AC Mains (line) Voltage on the ratings plate – a 220V unit will not turn on when connected to 115V AC Mains</p> <p>Verify the front panel power switch is in the “1” (on) position (depressed).</p>
Cannot enable the RF output by pressing the front panel RF ON/OFF button	<p>Ensure the Analog Interface Connector is fully seated and the Analog Interface “INTERLOCK” signal is at a TTL “low” state – apply a TTL “low” signal to pin 2 of the Analog Interface Connector or connect pins 2 and 15 together on Analog Interface Connector.</p> <p>Verify the unit is in “Panel” control mode – check the front panel display, line 2, left-hand side. “PANEL” should be displayed. For information on changing control mode, refer to the “Control Source” heading in the Operation section.</p>
Cannot enable the RF output by pressing the front panel RF ON/OFF button, or via the Analog or Serial Interfaces. The text “EXT” is shown on line 2 of the front panel display	<p>The Analog Interface “INTERLOCK” signal is at a TTL “HIGH” state – disabling the RF output.</p> <p>Ensure the Analog Interface Connector is fully seated</p> <p>Apply a TTL “low” signal to pin 2 of the Analog Interface Connector or connect pins 2 and 15 together on Analog Interface Connector.</p>
When in ANALOG control mode, the RF output power is erratic and/or fluctuates.	<p>Ensure the GROUND RETURN (GND) signal at pin 16, 17, 18, 21, or 23 of the Analog Interface connector is connected to the same ground reference as the SETPOINT source signal (Analog Interface Connector pin 13).</p> <p>The SETPOINT signal is a differential input. For proper operation, the GROUND RETURN (GND) signal must be referenced to the same ground reference as the setpoint</p>

<b>Condition</b>	<b>Suggested Solution</b>
	<p>source signal.</p> <p>Ensure the setpoint signal is connected to the Analog Interface Connector with shielded cable.</p>
<p>The text “EXT” is shown on line 2 of the front panel display</p>	<p>The Analog Interface “INTERLOCK” signal is at a TTL “HIGH” state – disabling the RF output.</p> <p>Ensure the Analog Interface Connector is fully seated</p> <p>Apply a TTL “low” signal to pin 2 of the Analog Interface Connector or connect pins 2 and 15 together on Analog Interface Connector.</p>
<p>The text “PAC” is shown on line 2 of the front panel display</p>	<p>The Power Amplifier’s Current limit threshold has been met or exceeded. The RF Power Supply is now limiting forward power to prevent the power amplifier current from increasing.</p> <p>Check the system to see if there is a problem with the load or check the external matching network (if present) and ensure it is operating properly.</p> <p>Decrease the power setpoint.</p>
<p>The text “REF” is shown on line 2 of the front panel display</p>	<p>The Reflected Power Alarm threshold has been met or exceeded. The RF Power Supply is now limiting forward power to prevent reflected power from increasing.</p> <p>Check the system to see if there is a problem with the load or check the external matching network (if present) and ensure it is operating properly.</p> <p>The Reflected Power Alarm threshold is set too low for the current process. Check the process specifications and/or the Reflected Power Alarm threshold setting (refer to the Programmable Parameters section).</p> <p>Decrease the power setpoint.</p>
<p>The text “MAX” is shown on line 2 of the front panel display</p>	<p>The Maximum Power Limit threshold has been met or exceeded.</p> <p>The Maximum Power Limit threshold is set too low for the current process. Check the process specifications and/or the Maximum Power Limit threshold setting (refer to the Programmable Parameters section).</p> <p>Decrease the power setpoint.</p>





## **SEREN 1 Year Limited Warranty**

SEREN IPS Inc. products are warranted to the original purchaser against defects in material and workmanship for a period of one year from the date of delivery.

SEREN IPS Inc. will repair or replace, at its option, all defective products returned freight prepaid during the warranty period, without charge, provided that there is no evidence the product has been mishandled, abused, or misapplied. Our liability under this warranty is limited to servicing, repairing, or replacing any defective products for a period of one year after delivery to the original purchaser.

If warranty service is required, the equipment must be returned, transportation charges prepaid, to our factory or authorized service depot. In the case of misuse, abnormal operating conditions, or other non-warranty work, a repair cost estimate will be submitted for approval before work is started.

### WHAT THE WARRANTY DOES NOT COVER:

This warranty covers only defects in materials and workmanship provided by SEREN I.P.S. and does not cover equipment damage or malfunction from misuse, abuse, accident, act of God, non-SEREN I.P.S. modification or upgrade. Improper return shipping, packaging, or shipping damage is not covered. SEREN I.P.S. will not be liable for any incidental or consequential damages resulting from your use or inability to use your RF Power Supply.

### IF YOU HAVE A PROBLEM

The first step is to contact your system vendor. Consult with your system vendor to determine the nature of the problem. Your system vendor knows the intimate details of how your processing system interfaces and operates with the R301 RF Power Supply and can efficiently resolve system related problems.

If it is determined that the RF Power Supply has a problem, contact our customer service department at **1-856-205-1131**. Before you call, please be ready to provide the model of your RF Power Supply, its serial number, date of manufacture, a description of the problem, and the model and manufacturer of the processing system it is used on.

### HOW IS WARRANTY SERVICE OBTAINED?

Our customer service representative will explain how to obtain service under this warranty. Please save the original packing materials in order to facilitate shipment.

## Glossary of Terms

A	Amperes, a measurement unit of current
AC	Alternating Current
ANLG	Abbreviation, "Analog"
Chamber	Industry term for a vacuum chamber used in plasma processing equipment.
Common Exciter (CEX)	A method of using an external frequency source to synchronize the outputs of RF Power Supplies in a multi-power supply system.
DC	Direct Current
D-Sub	Industry term for D-Subminiature connector
Equipotential Bond Equipotential Bonding	Equipotential bonding (often referred to as grounding) is used to control RF circulating currents within a system. For regulatory purposes, it is not a "Protective Earth" or "Safety Ground", even though it may be bonded to the "Protective Earth" or "Safety Ground" within the equipment or user's facility.
Exciter	A Radio Frequency source. RF Power Supplies amplify a RF signal source. The RF frequency signal source may be internally generated or externally supplied. (see Common Exciter).
Forward (net) Power Leveling	$(\text{Forward Power}) - (\text{Reflected Power}) = \text{Net Power}$ Using the calculated Net Power as the feedback source for power leveling (regulation).
FWD	Abbreviation, "FORWARD"
KHz	Kilo Hertz, a measurement unit of frequency (1000 Hertz)
KVA	Kilo Volt-Amperes
Load Power Leveling	Using the internal Forward Power sensor as the feedback source for power leveling (regulation).
Matchbox	Industry term for an impedance matching network
MHz	Mega Hertz, a measurement unit of frequency (1,000,000 Hertz)
mV	Milli-Volts, a measurement unit of Voltage, equal to 1/1000 of a Volt.
Net Power	The difference between forward power and reflected power.
Non-Volatile Storage	Also know as non-volatile memory. Computer memory that retains its data after power has been removed.



RF	Radio Frequency
RF Generator	Industry term for Radio Frequency Power Supply
TTL	Transistor-Transistor Logic
Tuner	Industry term for an impedance matching network
VAC	Volts, Alternating Current
VDC	Volts, Direct Current
VLT	Abbreviation, "VOLTAGE"
Voltage Control	Using an external DC voltage derived from the processing system as a feedback signal for power leveling (regulation)
W	Watts

**Revision History:**

<b>Revision</b>	<b>Date</b>	<b>Revision Description</b>
0.01	10/19/03	Preliminary
0.02	10/27/03	Updated Table of Contents, Analog Interface, and Technical Data Sections.
0.03	12/18/03	Deleted "A" from model number, updated illustrations.
0.04	4/1/04	Corrected Typical Interface Connection diagram, added maximum current and inrush current to technical specifications.
0.05	10/18/04	Added descriptions of probe inverter option, updated analog interface connector to include probe inverter option, added sections "External Feedback with Probe Inverter Option" and External Feedback with SEREN IPS AT-Series Matching Network", added Programmable Parameter Reference and Programmable Parameter Detail sections, expanded problem solving chart, updated serial interface connector section.