



CTI-Cryogenics
High Capacity Helium Compressor
Installation, Operation and
Maintenance Instructions



FOR SALES AND SERVICE PLEASE CALL:

PTB SALES T :: 626.334.0500
service@ptbsales.com
www.ptbsales.com

DATE SERVICED: _____

VIEW OUR INVENTORY

Information provided within this document is subject to change without notice, and although believed to be accurate, Brooks Automation assumes no responsibility for any errors, omissions, or inaccuracies.

AcuLigner™, Align™, AquaTran™, AutoTeach™, ATR™, AXM™, Basic Blue™, BiSymmetrik™, CenterSmart™, Cool Solutions™, Crate to Operate™, e-RMA™, e-Spares™, e-Volution™, FastRegen™, FIXLOAD™, FrogLeg™, InLigner™, InCooler™, Interface™, Jet Engine™, LowProfile™, M2 Nano™, Mini-Ion™, PASIV™, PowerPak™, PerformanceBlue™, PowerPak™, PowerTools™, QuadraFly™, Radius™, Radiant™, Radiant Express™, Reliance™, Reliance ATR™, RetroEase™, SCARA™, SmartPM™, SPOTLevel™, Synetics™, The New Pathway to Productivity™, Time Optimized Trajectory™, Time Optimal Trajectory™, Time Optimized Path™, TopCooler™, TopLigner™, Ultimate Blue™, VAC-407™, VacuTran™, Vacuum Quality Monitor™, VQM™, Vacuum Quality Index™, VQI™, and the Brooks logo are trademarks of Brooks Automation, Inc.

AcuTran®, AquaTrap®, Conductron®, Convector®, the Cool Solutions logo, Cryodyne®, Cryotiger®, Cryo-Torr®, Fusion®, GOLDLink®, Granville-Phillips®, Guardian®, GUTS®, Helix®, Jet®, Leapfrog®, MagnaTran®, MapTrak®, Marathon®, Marathon 2®, Marathon Express®, Micro-Ion®, MiniConvector®, On-Board®, Polycold®, Razor®, Simplicity Solutions®, the Simplicity Solutions logo, Stabil-Ion®, TrueBlue®, TurboPlus®, Vision®, Zaris®, and the Brooks Automation logo are registered U.S. trademarks of Brooks Automation, Inc.

All other trademarks are properties of their respective owners.

© 2013 Brooks Automation, Inc. All Rights Reserved. The information included in this manual is Proprietary Information of Brooks Automation and is provided for the use of Brooks Automation customers only and cannot be used for distribution, reproduction, or sale without the express written permission of Brooks Automation. This information may be incorporated into the user documentation, however any changes made by the user to this information is the responsibility of the user.



For Technical Support:

Location	GUTS® Contact Number
North America	+1-800-FOR-GUTS (1-800-367-4887) +1-978-262-2900
Europe	+49-1804-CALL-GUTS (+49-1804-2255-4887)
Japan	+81-45-477-5980
China	+86-21-5131-7066
Taiwan	+886-3-5525225
Korea	+82-31-288-2500
Singapore	+65-6464-1481

Visit us online: www.brooks.com

January 15, 2013 Part Num 8040600 Revision A

This technology is subject to United States export Administration Regulations and authorized to the destination only; diversion contrary to U.S. law is prohibited.

Printed in the U.S.A.

Contents

Figures vii

Tables ix

Introduction

CTI-CRYOGENICS Helium Refrigeration System 1-3

Specifications 1-5

- Dimensions 1-5
- Weight 1-6
- Electrical 1-6
- Cooling Water 1-7
- General 1-9

Electrical Box Front Panel Component Description 1-11

- Low Helium Pressure 1-11
- Power On 1-12
- CB2 1-12
- Module 1, 2, and 3 Status Indicators 1-12
- Emergency Off Button 1-12
- Supply Pressure Gauge 1-12

Electrical Box Rear Panel Component Description 1-13

- Logic Module Panel 1-13
- RS-232 1-13
- LED Indicator 1-13
- ID 1-14
- P2 and MNS LED 1-14
- MAC ID 1-14
- CCJ1/CCP2 Connectors 1-15
- Reverse Phase 1-15

Main Circuit Breaker 1-15

High Capacity Helium Compressor Rear Panel Component Description 1-16

 Helium In Return 1-16

 Helium Out Supply 1-16

 Water Out 1-16

 Water In 1-16

 Return Pressure Gauges 1-16

 Helium Charge 1-16

Typical On-Board 8F Cryopump for 300mm PVD System 1-18

Safety

Introduction 2-2

Signal Word Descriptions 2-3

Safety Shape Descriptions 2-4

References 2-4

Unpacking and Inspection

Shipping Carton Inspection 3-2

 Removal from Shipping Carton 3-2

Alternate Removal Method 3-4

High Capacity Helium Compressor Inspection 3-6

 Compressor 3-6

 Helium Static Pressure Verification 3-6

 Shipping Carton Contents 3-6

 Removing the Wheel Assemblies (Optional) 3-6

Installation

Introduction 4-2

Supply and Return Water Line Connections 4-4

 Hard Water Lines 4-4

 Flexible Water Lines 4-4

Electrical Connections 4-5

 Power Cable Preparation 4-5

 Phase Check 4-8

 RS-232 Cable Connections (Optional) 4-9

Emergency Off (EMO) System Connections	4-9
Multiple On-Board 8F Cryopump for 300mm PVD Flexline Connections	4-10
Helium Line Connections	4-10

Operation

Adjusting System Helium Pressure	5-1
Static Helium System Pressure Verification.	5-2
Start-up	5-2
Shutdown	5-3
Replacement of Helium Circuit Components	5-3

Maintenance

Scheduled Maintenance	6-2
Suggested Maintenance Equipment	6-2
Adsorber Replacement	6-2
Adjusting System Helium Pressure	6-5
Reducing Helium Pressure.	6-5
Increasing Helium Pressure	6-5
Adding Helium	6-5

Troubleshooting

Troubleshooting the High Capacity Helium Compressor.	7-2
Technical Inquiries.	7-2

Appendices

Appendix A: Customer Support Information	8-2
Customer Support Center Locations.	8-2
Guaranteed Up-Time Support (GUTS [®])	8-2
Product Information	8-2
E-mail.	8-2
Appendix B: Diagrams	8-3

Index	1
-----------------	---

This Page Intentionally Left Blank

Figures

Figure	Title	Page
3-1	Removing the High Capacity Helium Compressor from the Shipping Carton.	3-3
3-2	Alternate High Capacity Helium Compressor Removal Method	3-5
3-3	Wheel Assembly Bolt Locations	3-7
4-1	High Capacity Helium Compressor Installation Flowchart.	4-3
4-2	High Capacity Helium Compressor Power Cable Connections	4-6
4-3	Power Cord Installation.	4-7
4-4	Proper Connection/Disconnection Technique for Helium Line Couplings.	4-11
6-1	Disconnecting/Connecting Self Sealing Couplings	6-3
6-2	Adsorber Location within the High Capacity Helium Compressor (Rear Panel Removed)	6-4
B-1	Logic Module Connector P2 Pinout Diagram.	8-3
B-2	EMO Connector Schematic	8-4
B-3	Tower Compressor Electrical Chassis Top View (Cover Removed).	8-5
B-4	Helium Flow Diagram - Two Modules	8-6
B-5	Low Voltage Electrical Schematic	8-8
B-6	High Voltage Electrical Schematic.	8-9

This Page Intentionally Left Blank

Tables

Table	Title	Page
1-1	High Capacity Helium Compressor Weight	1-6
1-2	Electrical Input Specifications	1-6
1-3	General High Capacity Helium Compressor Operating Specifications ..	1-9
1-4	MNS LED Status Indications	1-14
2-1	Safety Signal Words.....	2-3
2-2	Safety Shapes	2-4
4-1	Required Components for High Capacity Helium Compressor Installation	4-2
6-1	Suggested Maintenance Equipment	6-2
B-1	Helium Flow Diagram - Three Modules	8-7

This Page Intentionally Left Blank

1

Introduction

General

This manual provides the information required to install, operate, and maintain the CTI-CRYOGENICS High Capacity Helium Compressor.

NOTE: All personnel with installation, operation, and maintenance responsibilities should become familiar with the contents of both the High Capacity Helium Compressor Installation, Operation, Maintenance, and the On-Board 8F Cryopump for 300mm PVD manual to ensure safe, and reliable system performance.

Refer to Appendix A - Customer Support Information to contact the local Customer Support Center for information about connecting 9600 Compressors to a manifold with other CTI-Cryogenics compressors.

Chapter Contents

CTI-CRYOGENICS Helium Refrigeration System	1-3
Specifications	1-5
Dimensions	1-5
Weight	1-6
Electrical	1-6
Cooling Water	1-7
General	1-9
Electrical Box Front Panel Component Description	1-11
Low Helium Pressure	1-11
Power On	1-12
CB2	1-12
Module 1, 2, and 3 Status Indicators	1-12
Emergency Off Button	1-12
Supply Pressure Gauge	1-12
Electrical Box Rear Panel Component Description	1-13
Logic Module Panel	1-13
RS-232	1-13

LED Indicator	1-13
ID	1-14
P2 and MNS LED	1-14
MAC ID	1-14
CCJ1/CCP2 Connectors	1-15
Reverse Phase	1-15
Main Circuit Breaker	1-15
High Capacity Helium Compressor Rear Panel Component Description	1-16
Helium In Return	1-16
Helium Out Supply	1-16
Water Out	1-16
Water In	1-16
Return Pressure Gauges	1-16
Helium Charge	1-16
Typical On-Board 8F Cryopump for 300mm PVD System	1-18

Compressor Configurations

The High Capacity Helium Compressor is available in two or three module configurations with low and high input voltages. The two module configuration, shown in [Figure 1-10](#), provides enough compressed helium to supply eight (8) On-Board 8F Cryopumps for PVD Operation. The three module configuration, shown in [Figure 1-11](#), provides enough compressed helium to supply twelve (12) On-Board 8F Cryopumps for PVD Operation. Refer to [Table 1-1](#), [1-2](#), [1-3](#) and [1-4](#) for specifications on each configuration.

System Documentation

The manuals for a *system* cover three basic components: the On-Board 8F Cryopump for 300mm PVD, the High Capacity Helium Compressor and the Network Terminal (48 VDC). A manual is shipped with each system component to provide information for installation and operation of that component. A loose-leaf binder with index tab separators is also provided so that a complete set of tabulated manuals can be compiled.

CTI-CRYOGENICS Helium Refrigeration System

The operation of CTI-CRYOGENICS' On-Board 8F Cryopump for 300mm PVD is based upon a closed loop helium expansion cycle. The system is made up of two major components: the On-Board 8F Cryopump for 300mm PVD, which contains the cold head, and the High Capacity Helium Compressor which compresses the helium gas.

Refrigeration is produced in the On-Board 8F Cryopump for 300mm PVD cold head through periodic expansion of high pressure helium in a regenerative process.

The high pressure helium is provided by the High Capacity Helium Compressor. Low pressure helium returning from the cold head is compressed into the necessary high pressure to be returned to the cold head. A large portion of the energy required to compress the helium is rejected as heat through the High Capacity Helium Compressor cooling water.

High pressure room temperature helium is transferred to the cold head through the helium supply lines. After expansion in the coldhead, low pressure helium is returned (at or near room temperature) to the Compressor. The cycle is repeated in a closed loop fashion. Large separation distances can be accommodated between the High Capacity Helium Compressor and the On-Board 8F Cryopump for 300mm PVD.

In the High Capacity Helium Compressor, helium is compressed using highly reliable oil lubricated pump. Oil removal from the helium takes place via several stages of oil removal.

The final stage of purification is performed with two (2) or three (3) replaceable adsorber cartridges. To maintain peak efficiency, the adsorber must be replaced every three years.

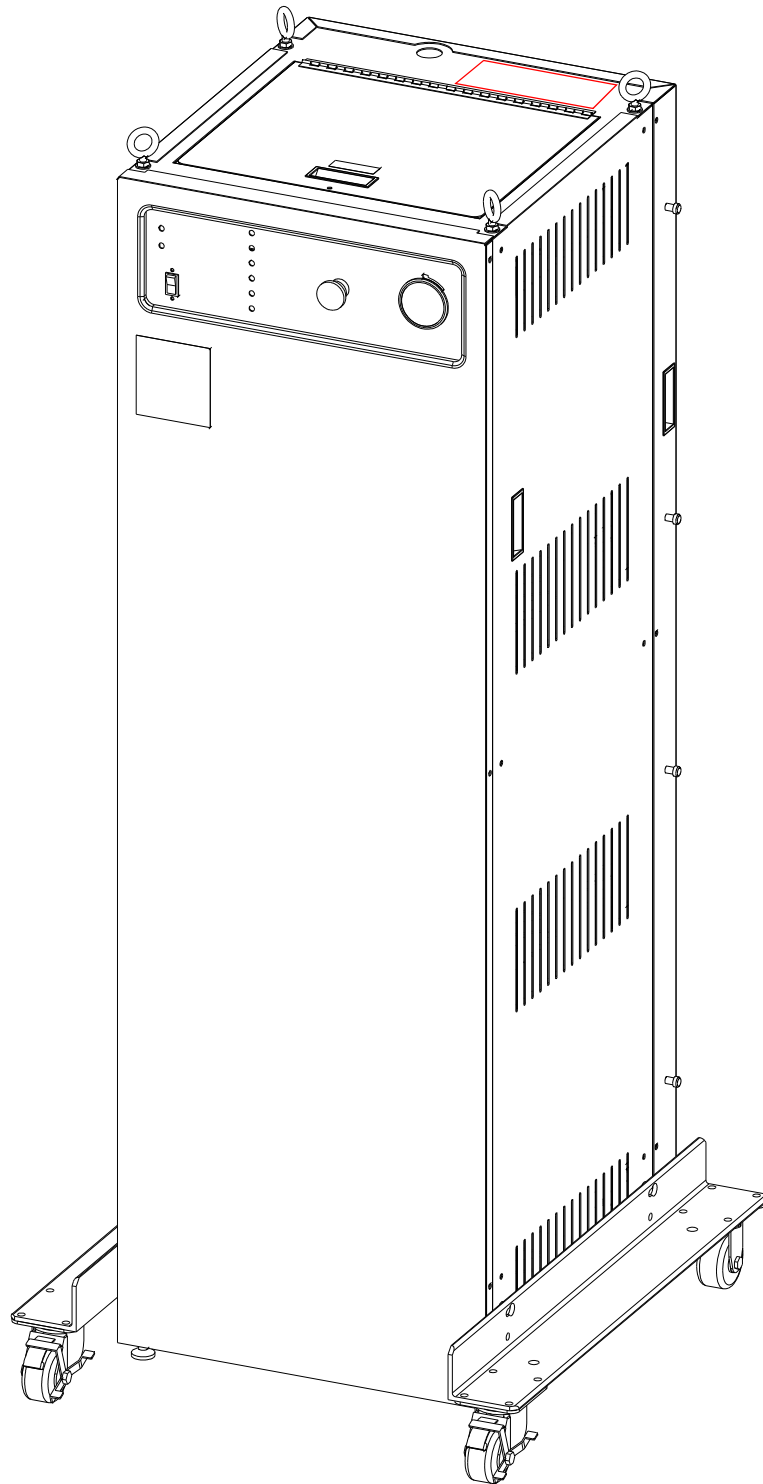

Figure 1-1: High Capacity Helium Compressor (Front View)

Specifications

Dimensions

The dimensions of the High Capacity Helium Compressor are shown in [Figure 1-2](#).

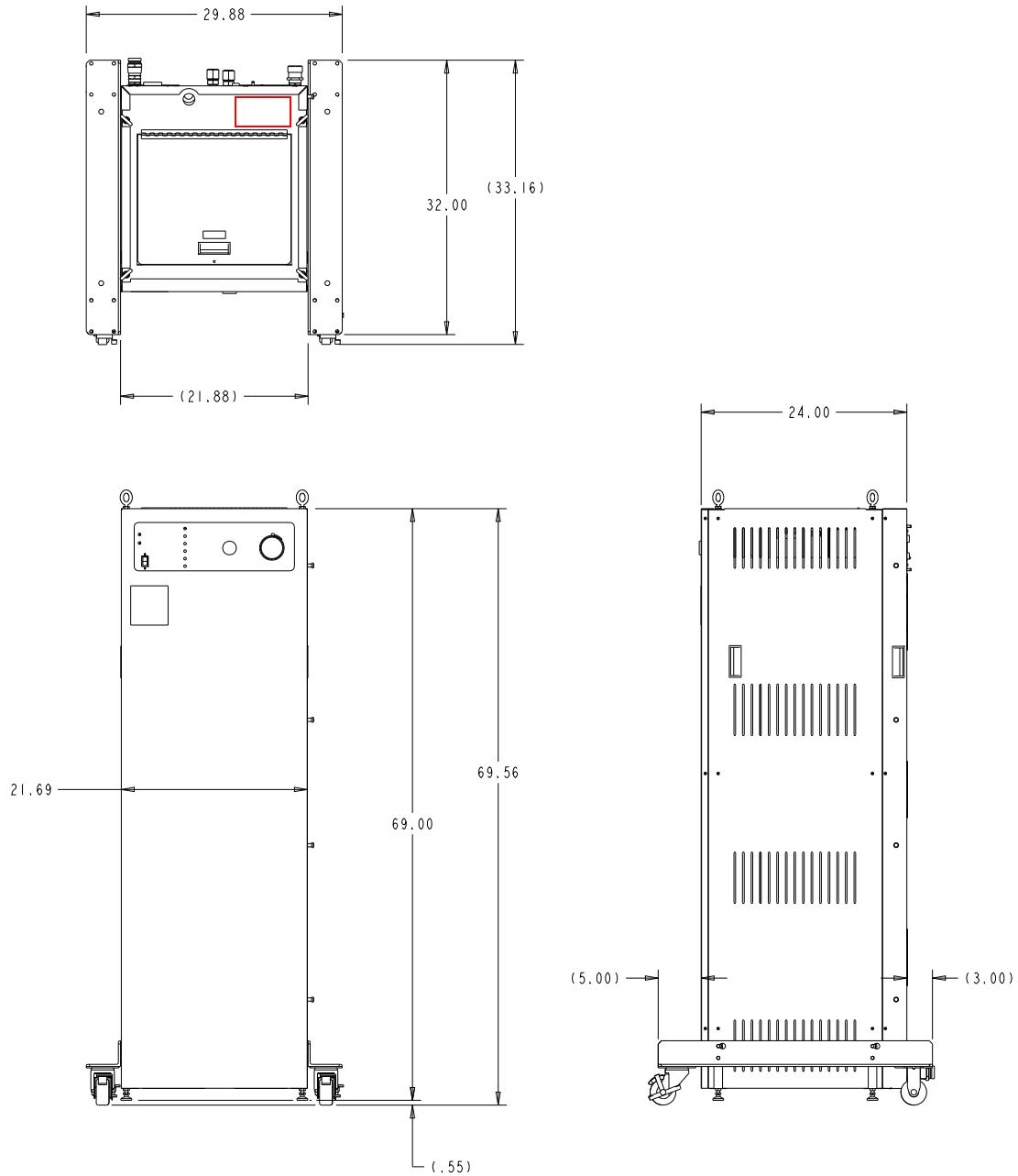



Figure 1-2: High Capacity Helium Compressor Dimensions

Weight

The weight of the High Capacity Helium Compressor is listed in [Table 1-1](#).

Table 1-1: High Capacity Helium Compressor Weight

Compressor Configuration	Weight lbs./kg
Low Voltage 3 Compressor Modules	820/372
High Voltage 3 Compressor Modules	830/376
Low Voltage 2 Compressor Modules	640/290
High Voltage 2 Compressor Modules	650/295

	<p>CAUTION</p> <p>Compressor Damage</p> <p>Do not place a weight greater than 75 lbs. (34Kg) on top of the High Capacity Helium Compressor, or the unit may be damaged.</p>
---	---

Electrical

The electrical specifications of the High Capacity Helium Compressor are listed in [Table 1-2](#).

Table 1-2: Electrical Input Specifications

Parameter	Low Voltage 3 Compressor Modules	High Voltage 3 Compressor Modules	Low Voltage 2 Compressor Modules	High Voltage 2 Compressor Modules
Input Voltage and Frequency	180-253 VAC 50/60Hz	342-528 VAC 50/60 HZ	180-253 VAC 50/60Hz	342-506 VAC 50/60 HZ
Phase	3	3	3	3
Nominal Input Power	18 KW @ 60 Hz 15 KW @ 50 Hz	18 KW @ 60 Hz 15 KW @ 50 Hz	12 KW @ 60 Hz 10 KW @ 50 Hz	12 KW @ 60 Hz 10 KW @ 50 Hz
Nominal Power Factor	0.9	0.85	0.9	0.85
Rated FL/LR Current	58/255	24/125 (480V 60Hz, 380V 50 Hz) 27/125 (480V 50Hz, 380V 60Hz)	39/170	18/83

Cooling Water

The water used to cool the High Capacity Helium Compressor must meet the specifications shown in [Table 1-3](#) for proper system operation.

Figure 1-3: Cooling Water Specifications

Parameter	2 Compressor Modules	3 Compressor Modules
Maximum Inlet Temperature	90°F (32°C)	90°F (32°C)
Minimum Inlet Temperature	50°F (10°C)	50°F (10°C)
Flow Rate*	5.50 +/- 2.50 gpm (20.8 +/- 9.5 lpm)	8.25 +/- 3.75 gpm (31.2 +/- 14.2 lpm)
Pressure Drop (inlet-to-outlet) Refer to Figure 1-4	10.5 psi (0.72 bar) @ 5.5 gpm (20.8 lpm)	10 psi (0.69 bar) @ 8.25 gpm (31.2 lpm)
Maximum Inlet Pressure	100 psi (6.9 bars)	100 psi (6.9 bars)
Alkalinity**	6.0 - 8.0 pH	6.0 - 8.0 pH
Calcium Carbonate**	< 75 ppm	< 75 ppm
<p>*NOTE: Refer to Figure 1-5 and Figure 1-6 for high voltage configurations. **NOTE: Water conditioning is required for applications not meeting these requirements.</p>		

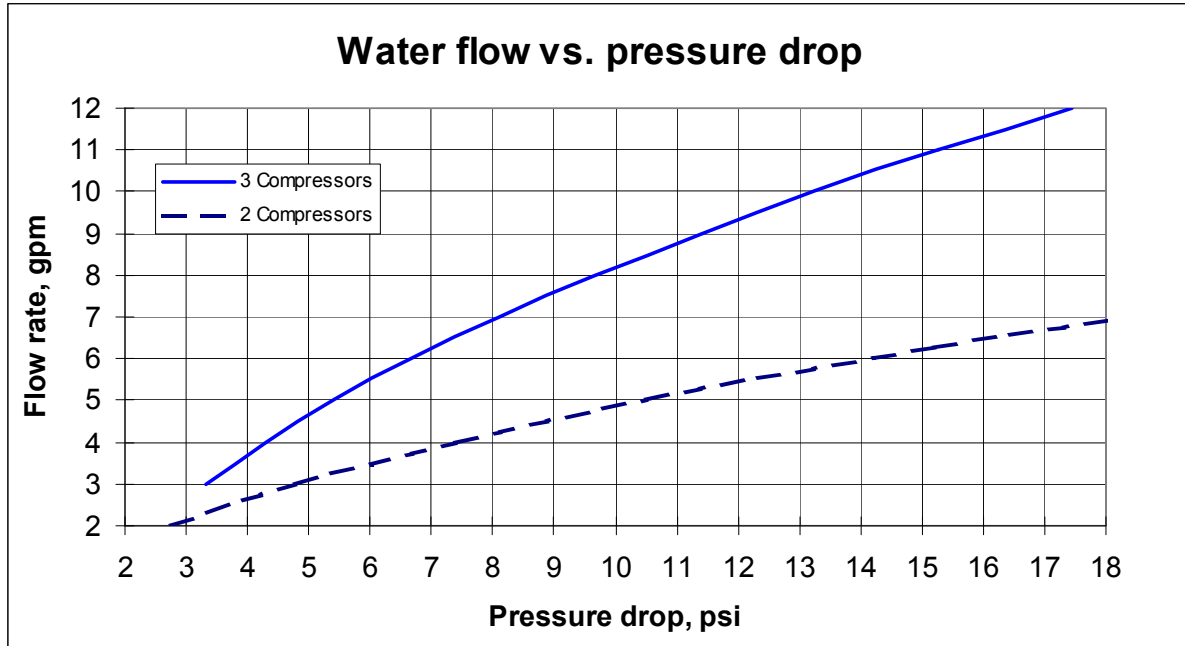

Figure 1-4: Water Flow Rate versus Pressure Drop

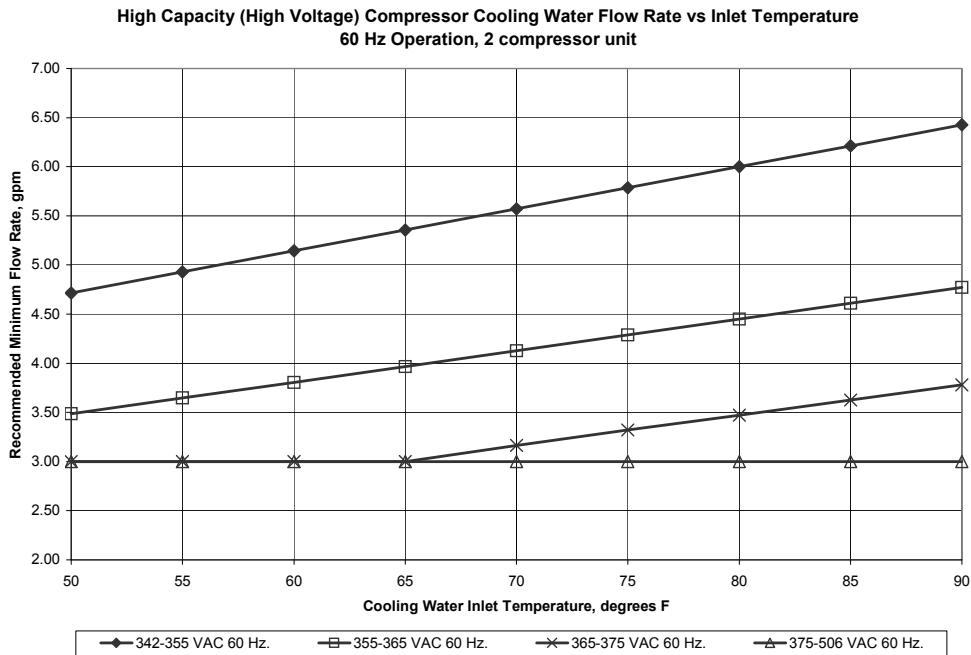

Figure 1-5: Cooling Water Flow versus Inlet Temperature
(Two Compressor Modules High Voltage Configuration)

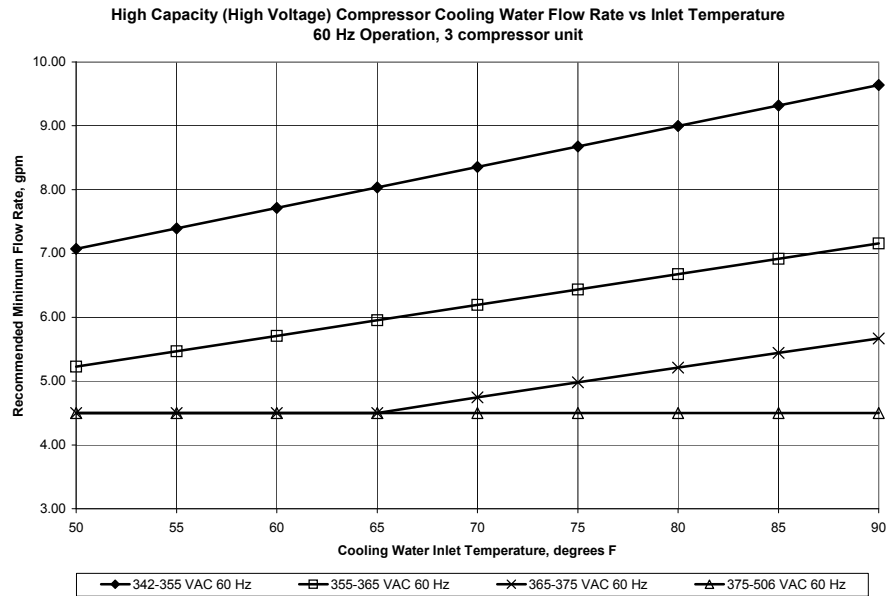

Figure 1-6: Cooling Water Flow versus Inlet Temperature
(Three Compressor Modules High Voltage Configuration)

General

The information in [Table 1-3](#) provides general High Capacity Helium Compressor operating specifications.

Table 1-3: General High Capacity Helium Compressor Operating Specifications

Specification	Low Voltage	High Voltage
Part Number	8128908G001 - 3 modules 8128904G003 - 2 modules 8128903G003 - 3 modules	8128908G002 - 3 modules 8128904G004 - 2 modules 8128903G004 - 3 modules
Input Power Cable (Check local electrical codes.)	3 conductor cable with ground Rated 600 VAC Check local electrical codes	3 conductor cable with ground Rated 600 VAC Check local electrical codes
Helium Static Pressure	325 - 335 psig (22.4 - 23.1 bars)	325 - 335 psig (22.4 - 23.1 bars)
Ambient Operating Temperature Range	50 - 100° F (10 - 38° C)	50 - 100° F (10 - 38° C)

Table 1-3: General High Capacity Helium Compressor Operating Specifications (Continued)

Specification	Low Voltage	High Voltage
Gas Supply Connector	3/4 in. Aeroquip self-sealing coupling (female)	3/4 in. Aeroquip self-sealing coupling (female)
Gas Return Connector	3/4 in. Aeroquip self-sealing coupling (male)	3/4 in. Aeroquip self-sealing coupling (male)
Adsorber Replacement Schedule	Every 3 Years	Every 3 Years

NOTE: The High Capacity Helium Compressor is designed for continuous operation and should remain ON when the On-Board 8F Cryopump for 300mm PVD is in a regeneration cycle.

Electrical Box Front Panel Component Description

The Electrical Box Front Panel for both 2 and 3 compressor modules is shown in [Figure 1-7](#) and described in the following paragraphs.

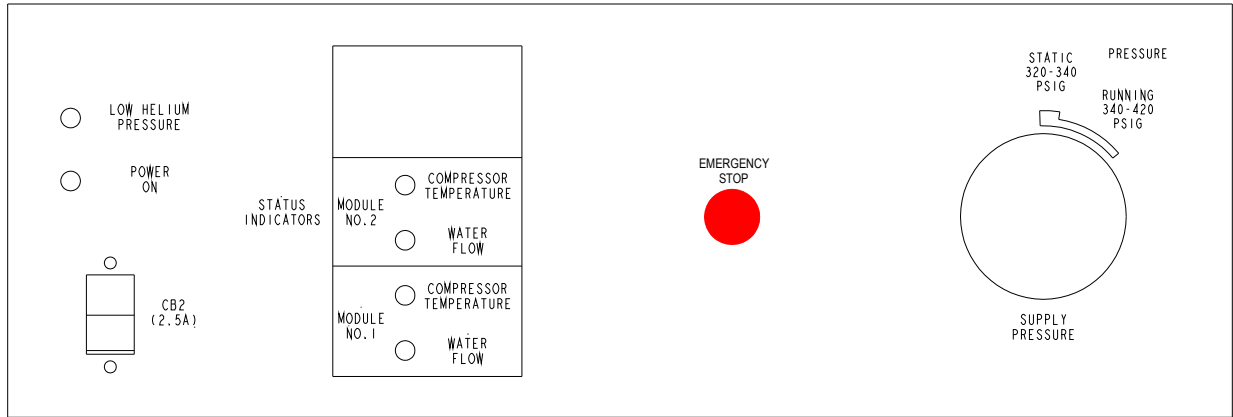

TWO COMPRESSOR MODULE PANEL

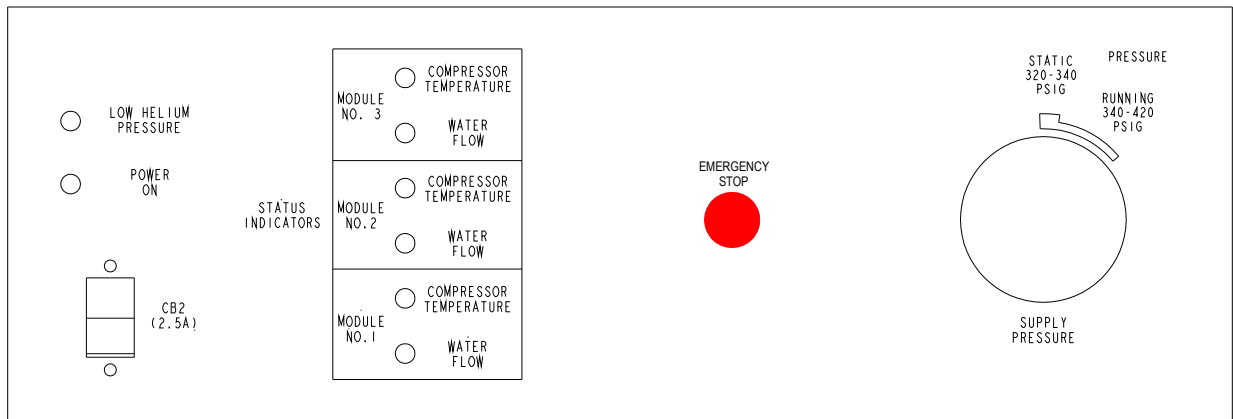

THREE COMPRESSOR MODULE PANEL

Figure 1-7: Electrical Box Front Panel Components

Low Helium Pressure

The Low Helium Pressure indicator illuminates when the helium operating pressure (return pressure) drops below 140 psig (9.6 bar). The High Capacity Helium Compressor will automatically shut down if the helium return pressure drops below 20 psig (1.38 bar).

NOTE: Refer to Section 7, Troubleshooting for more information if the Low Helium Pressure indicator is illuminated.

Power On

The Power On indicator illuminates when the control circuit breaker (CB2) is in the ON position and there is power to the High Capacity Helium Compressor unit.

CB2

The CB2 Circuit Breaker is used as an ON/OFF switch and provides current overload protection for all internal components of the High Capacity Helium Compressor except the Compressor motor. The High Capacity Helium Compressor motor is protected by a separate overload protector. The Control Circuit Breaker opens automatically when overloaded and must be reset manually.

Module 1, 2, and 3 Status Indicators

NOTE: The status indicators for Module No. 3 are not present on the two compressor module High Capacity Helium Compressor configuration.

The Over Temperature Indicator illuminates when the High Capacity Helium Compressor pump is automatically turned OFF due to a over-temperature condition within the High Capacity Helium Compressor pump module.

NOTE: Refer to Section 6, Troubleshooting, for more information if one of these indicators are illuminated.

The Water Over Temperature Indicator illuminates when the High Capacity Helium Compressor pump is automatically turned OFF due to insufficient cooling water flow rate within the High Capacity Helium Compressor pump module.

Emergency Off Button

The Emergency Off (EMO) button allows the entire process tool and the High Capacity Helium Compressor to be shut down in the event of an emergency. Refer to CCJI/CCP2 Connectors within this section for additional information.

Supply Pressure Gauge

The Supply Pressure Gauge indicates Compressor supply pressure when the High Capacity Helium Compressor is ON. Refer to for the appropriate static helium charge pressure. The Supply Pressure Gauge also indicates system static helium charge pressure when the High Capacity Helium Compressor and On-Board 8F Cryopump for 300mm PVD are OFF.

Electrical Box Rear Panel Component Description

The Electrical Box Rear Panel is shown in [Figure 1-8](#) and is described in the following paragraphs.

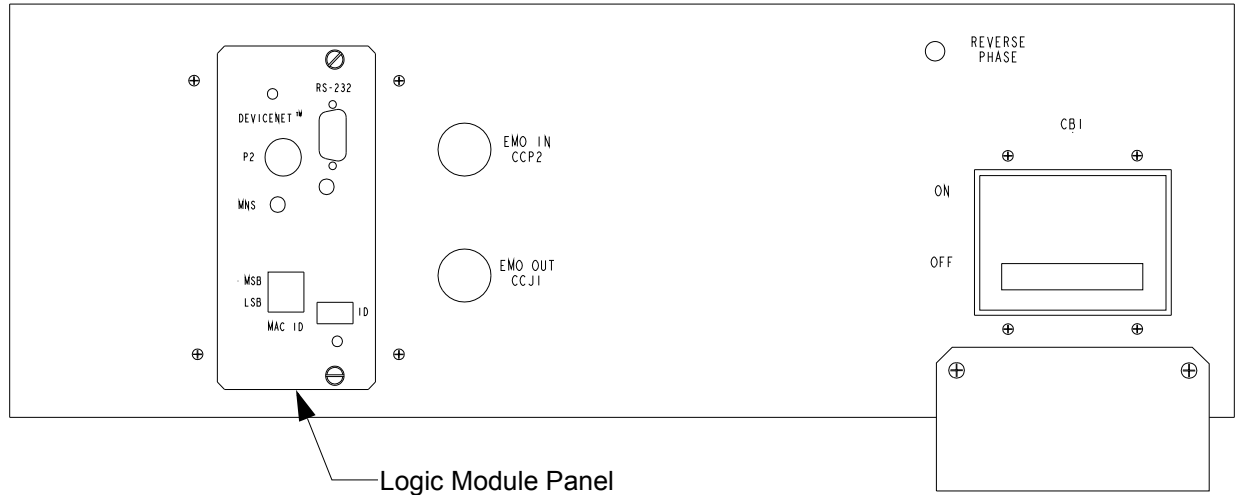

Figure 1-8: Electrical Box Rear Panel Components

Logic Module Panel

The Logic Module Panel, shown in [Figure 1-8](#), controls the operation of the High Capacity Helium Compressor and allows communication with the High Capacity Helium Compressor using RS-232 or DeviceNet connections.

RS-232

The RS-232 port allows a host computer to be connected to the High Capacity Helium Compressor. The RS-232 port supports a 9600 baud rate.

NOTE: To meet regulatory compliance, the RS-232 cable must be fully shielded through to the connector shell. Use cable CTI-CRYOGENICS P/N 8132157GXXX or equivalent. The RS-232 cable must also pass through ferrite to minimize losses along the cable. Refer to Section 3, Installation, for more information.

LED Indicator

The LED Indicator is a power indicator lamp that illuminates when the power switch is in the ON position. The indicator blinks or goes out if there is a logic module failure.

ID

The ID Switch allows selection of the On-Board Network (bitbus) address of the High Capacity Helium Compressor that is connected to the On-Board network. The address range is 0 - 9.

P2 and MNS LED

The P2 connector and the Module Network Status LED are both used in conjunction with the DeviceNet network. The LED is a bi-color (green/amber) device which provides limited communication status as listed in [Table 1-4](#). The connector type is a 5 PIN mini style with 7/8-16 UN-2A THD outside thread connection. The pin out diagram is shown in [Figure B-1](#) in Appendix B.

NOTE: The cable used for the P2 connector must be fully shielded by a drain wire and outer braid connected to the connector shell.

NOTE: Refer to Allen Bradley Publication DN-2.15 for more information on shielding the cable.

NOTE: Refer to DeviceNet documentation for more information on DeviceNet states and status messages.

Table 1-4: MNS LED Status Indications

LED State	Condition
OFF	High Capacity Helium Compressor power switch is OFF.
Green	Normal Operating Condition
Flashing Green	High Capacity Helium Compressor is operating normally, is on-line, with no connections in the established state.
Flashing Amber	Minor fault and/or connection time out.

MAC ID

Media Access Control ID switch allows selection of the DeviceNet address for the High Capacity Helium Compressor.

CCJ1/CCP2 Connectors

The CCJ1 (EMO Out) and CCP2 (EMO In) connectors allow connection of the High Capacity Helium Compressor to the process system Emergency Off (EMO) system. When connected, and if the EMO button on the front panel of the High Capacity Helium Compressor is pressed, the power to the entire process tool and High Capacity Helium Compressor system will be turned OFF.

The schematic diagram for the connectors is shown in [Figure B-3](#). If the EMO is not connected to the process system EMO, pushing the High Capacity Helium Compressor EMO will shut down the compressor.

Reverse Phase

The Reverse Phase indicator illuminates when the High Capacity Helium Compressor power cable has been connected out of phase. An out-of-phase condition will prevent the High Capacity Helium Compressor from operating. Refer to [Figure 1-8](#).

Main Circuit Breaker

The Main Circuit Breaker (CB1) provides circuit breaker protection for all high voltage components. Refer to [Figure 1-8](#).

	⚠ WARNING
	<p style="text-align: center;">High Voltage</p> <p>The Main Circuit Breaker must be switched to the OFF position before performing any work on the electrical components of the On-Board 8F Cryopump for 300mm PVD System to prevent electric shock.</p>

High Capacity Helium Compressor Rear Panel Component Description

Helium In Return

The Helium In Return coupling returns the helium, which has been cycled through the On-Board 8F Cryopump for 300mm PVD, back to the High Capacity Helium Compressor. Refer to [Figure 1-9](#).

Helium Out Supply

The Helium Out Supply coupling provides a connection for high pressure compressed helium to the On-Board 8F Cryopump for 300mm PVD cold head. Refer to [Figure 1-9](#).

Water Out

The Water Out connector returns the water that has been used to cool the High Capacity Helium Compressor to your facility. The connector is a 3/4 inch male ORS fitting. Refer to [Figure 1-9](#).

Water In

The Water In connector provides water to the High Capacity Helium Compressor from your facility to cool the High Capacity Helium Compressor during operation. The connector is a 3/4 inch male ORS fitting. Refer to [Figure 1-9](#).

NOTE: Refer to Section 6, Troubleshooting, for more information if the Reverse Phase indicator is illuminated.

Return Pressure Gauges

The Return Pressure Gauges indicate the helium pressure being returned from each compressor module within the rack. Refer to [Figure 1-9](#).

Helium Charge

The Helium Charge fitting and charge valve are used to add helium to the High Capacity Helium Compressor when helium charging is required. Refer to [Figure 1-9](#). The charge port is a 1/4 inch 45° male flare fitting, and mates with the CTI-CRYOGENICS' charge line P/N 7021002P001. Refer to Adjusting System Helium Pressure in Section 5 for additional information.

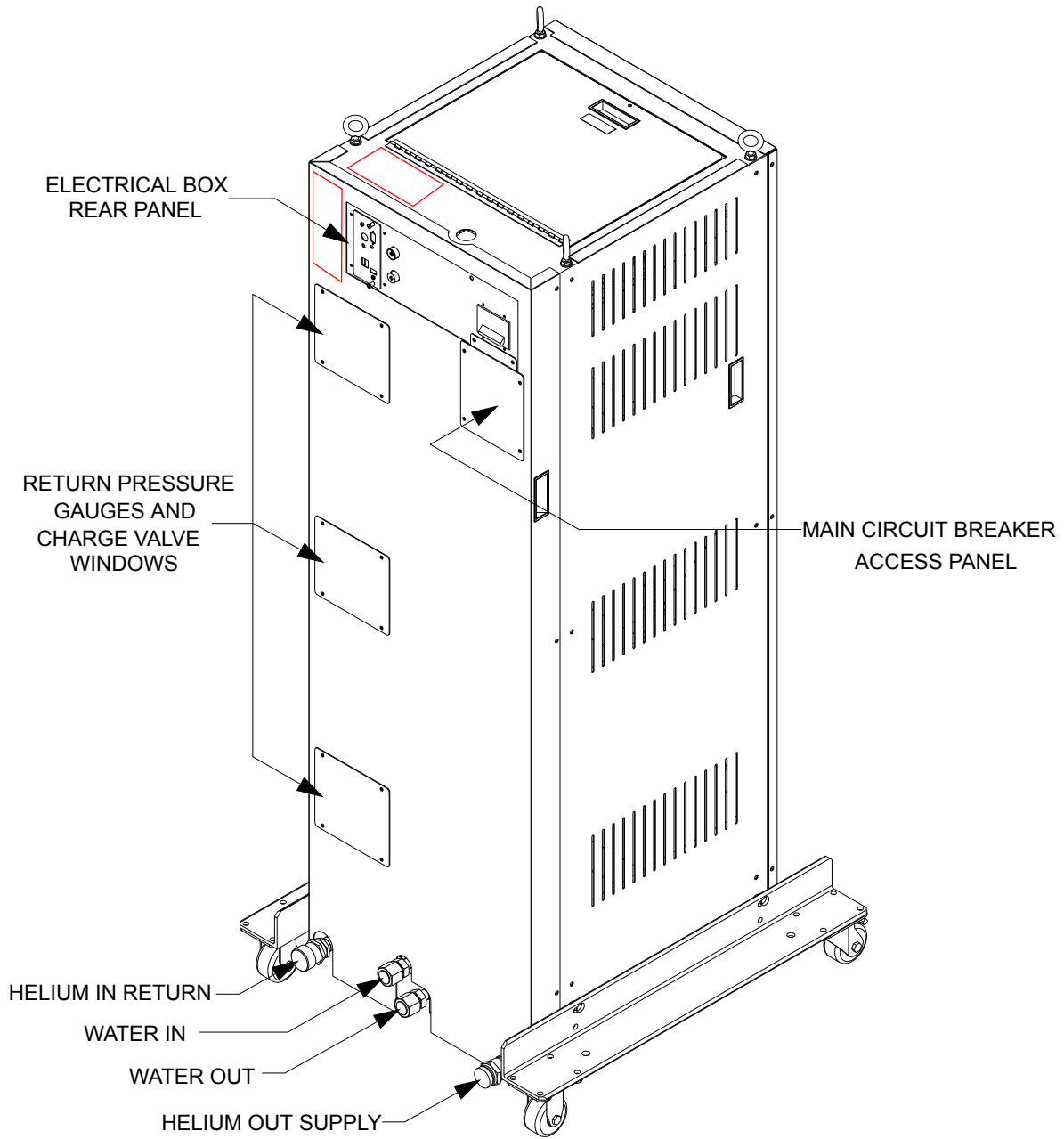

Figure 1-9: High Capacity Helium Compressor Rear Panel Component Location

Typical On-Board 8F Cryopump for 300mm PVD System

The High Capacity Helium Compressor equipped with two modules can provide a helium supply to a maximum of 8 On-Board 8F Cryopumps for 300mm PVD as shown in Figure 1-10. The three module configuration can provide a helium supply to a maximum of 12 On-Board 8F Cryopumps for 300mm PVD as shown in Figure 1-11.

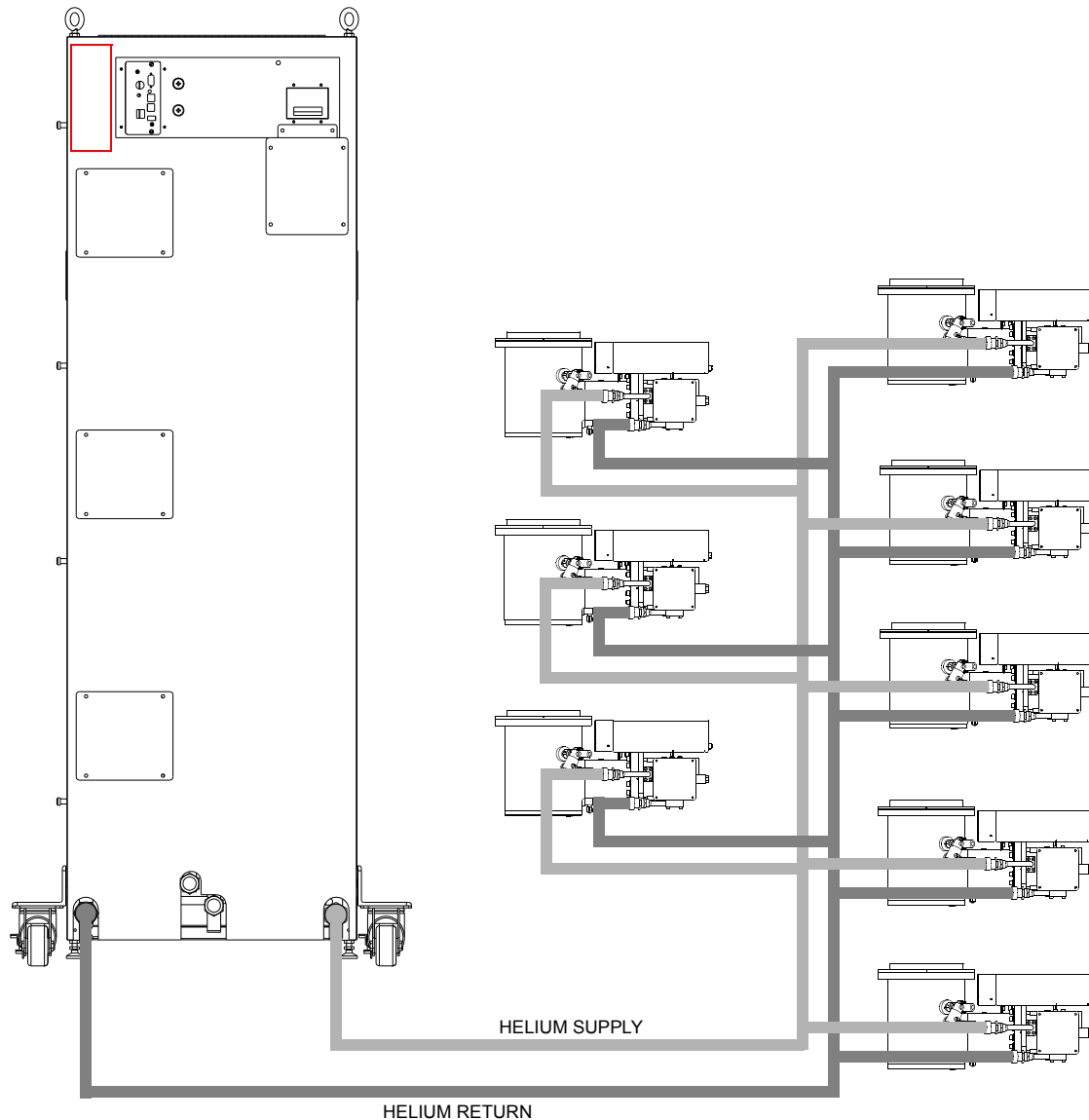

Figure 1-10: Typical On-Board 8F Cryopump for 300mm PVD System Helium Connections (Two Module Configuration)

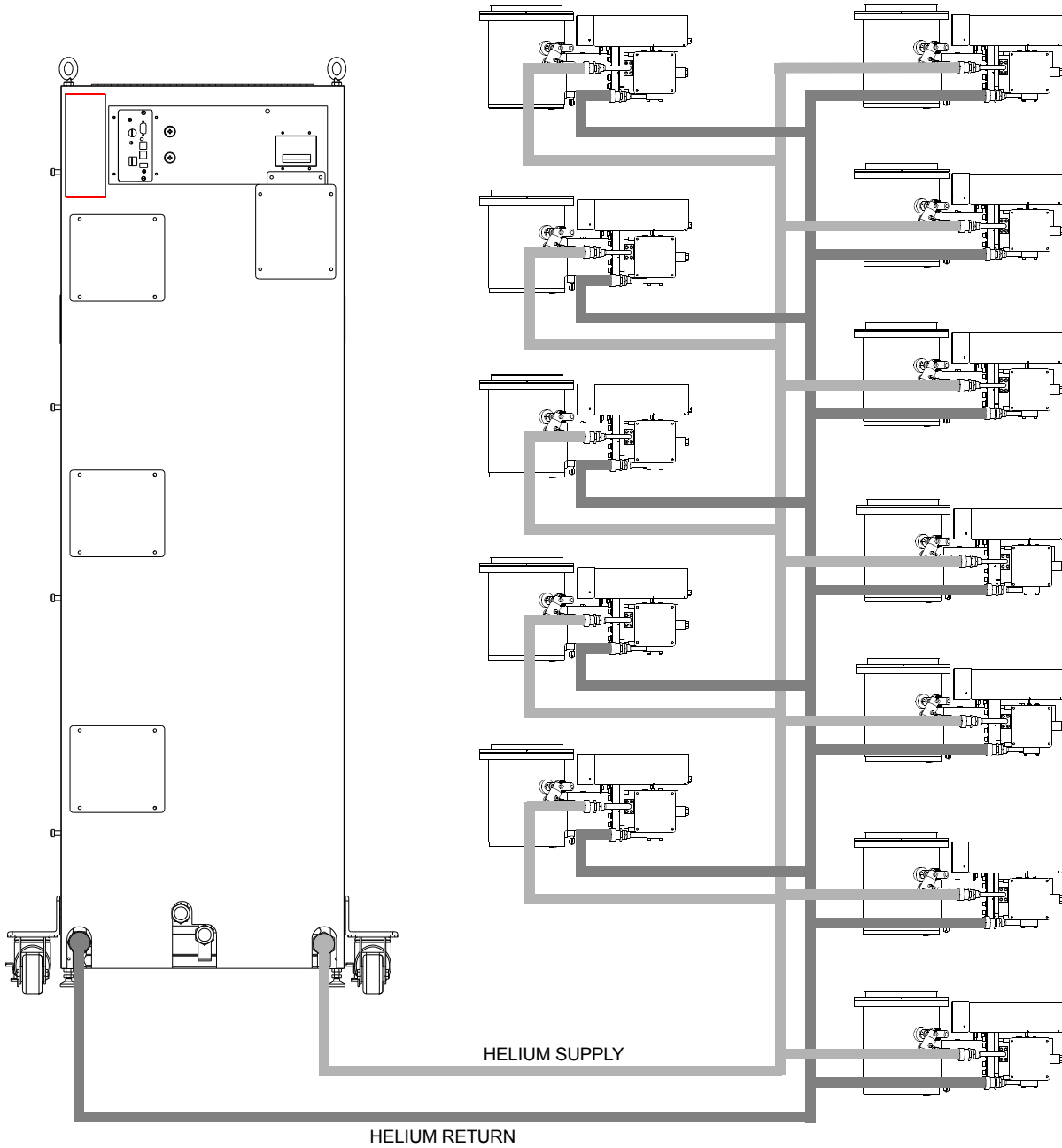

Figure 1-11: Typical On-Board 8F Cryopump for 300mm PVD System Helium Connections (Three Module Configuration)

Refer to Chapter 3 - Installation, for more information on connecting On-Board 8F Cryopump for 300mm PVD to the High Capacity Helium Compressor.

This Page Left Blank Intentionally

2

Safety

Overview

This section describes safety conventions for the Brooks Automation Product. All personnel involved in the operation or maintenance of the product must be familiar with the safety precautions outlined in this section.

NOTE: *These safety recommendations are basic guidelines. If the facility where the Product is installed has additional safety guidelines they should be followed as well, along with the applicable national and international safety codes.*

Chapter Contents

Introduction	2-2
Signal Word Descriptions.....	2-3
Safety Shape Descriptions.....	2-4
References	2-4

Introduction

Follow all safety precautions during installation, normal operation, and when servicing CTI-Cryogenics products.



This chapter explains the safety conventions used throughout this manual. CTI-Cryogenics uses a specific format for cautions and warnings, which includes standard signal words and safety shapes.

See also the *Customer Support* appendix or call your local Customer Support Center for assistance.

Signal Word Descriptions

All cautions and warnings contain signal words, which call attention to safety messages and designate the degree of hazard seriousness. The following table shows the signal words and their meanings that may be used in this document.



Table 2-1: Safety Signal Words

Term	Example	Definition
CAUTION		A signal word that indicates a situation or unsafe practice, which if not avoided may result in equipment damage . A CAUTION is highlighted in yellow.
CAUTION		A signal word accompanied by a safety shape that indicates a potentially hazardous situation or unsafe practice. If not avoided, the action may result in minor or moderate personal injury or equipment damage . A CAUTION is highlighted in yellow.
WARNING		A signal word accompanied by a safety shape that indicates a potentially hazardous situation. If not avoided, the action may result in serious injury or death . A WARNING is highlighted in orange.

Safety Shape Descriptions

All cautions and warnings contain safety shapes, which have specific safety meanings. The following table shows some of the safety shapes used in this document and their meanings.

Table 2-2: Safety Shapes

Example	Term	Shape Definition
	General Warning	Indicates a general hazard. Details about this hazard appear in the safety notice explanation.
	High Voltage	Indicates a high voltage hazard.
	Hot Surface	Indicates a surface is hot enough to cause discomfort or a burn.

References

For more information about safety standards, see the following documents:

- ISO 7010: 2003(E), Graphic symbols - Safety colours and safety signs - Safety signs used in workplaces and public areas
- ISO 3864-1: 2002(E), Graphic symbols - Safety colours and safety signs - Part 1: Design principles for safety signs in workplaces and public areas

3 Unpacking and Inspection

Overview

The High Capacity Helium Compressor is shipped in a carton that incorporates a ramp system to facilitate the removal of the High Capacity Helium Compressor from the carton.

Chapter Contents

Shipping Carton Inspection	3-2
Removal from Shipping Carton.....	3-2
Alternate Removal Method	3-4
High Capacity Helium Compressor Inspection	3-6
Compressor.....	3-6
Helium Static Pressure Verification	3-6
Shipping Carton Contents	3-6
Removing the Wheel Assemblies (Optional).....	3-6

Shipping Carton Inspection

Inspect the exterior of the shipping carton for visible signs of damage before opening the shipping carton. Report any damage to the shipping company at once.

Removal from Shipping Carton

Refer to [Figure 3-3-2](#) and use the following procedure to unpack the High Capacity Helium Compressor.

1. Cut the straps on the exterior of the shipping pallet.
2. Lift the cardboard carton straight up and remove it from the pallet.
3. Cut the strap and remove the bolts that attach the ramp to the shipping pallet.
4. Attach the ramp to the pallet and install the ramp pins in the pallet holes as shown in [Figure 3-3-1](#).
5. Remove any excess shipping material from around the High Capacity Helium Compressor.
6. Disengage the locks on the wheel assemblies.

	<p style="text-align: center;">CAUTION</p> <p style="text-align: center;">Tipover Hazard</p> <p>Injury to personnel may result if the High Capacity Helium Compressor is allowed to roll freely down the ramp. Two people are required to maintain control over the movement of the High Capacity Helium Compressor.</p>
---	--

7. Carefully roll the High Capacity Helium Compressor down the ramp and onto the floor.
8. Carefully move the High Capacity Helium Compressor into its installation position.
9. Refer to Section 3, Installation, for more information.

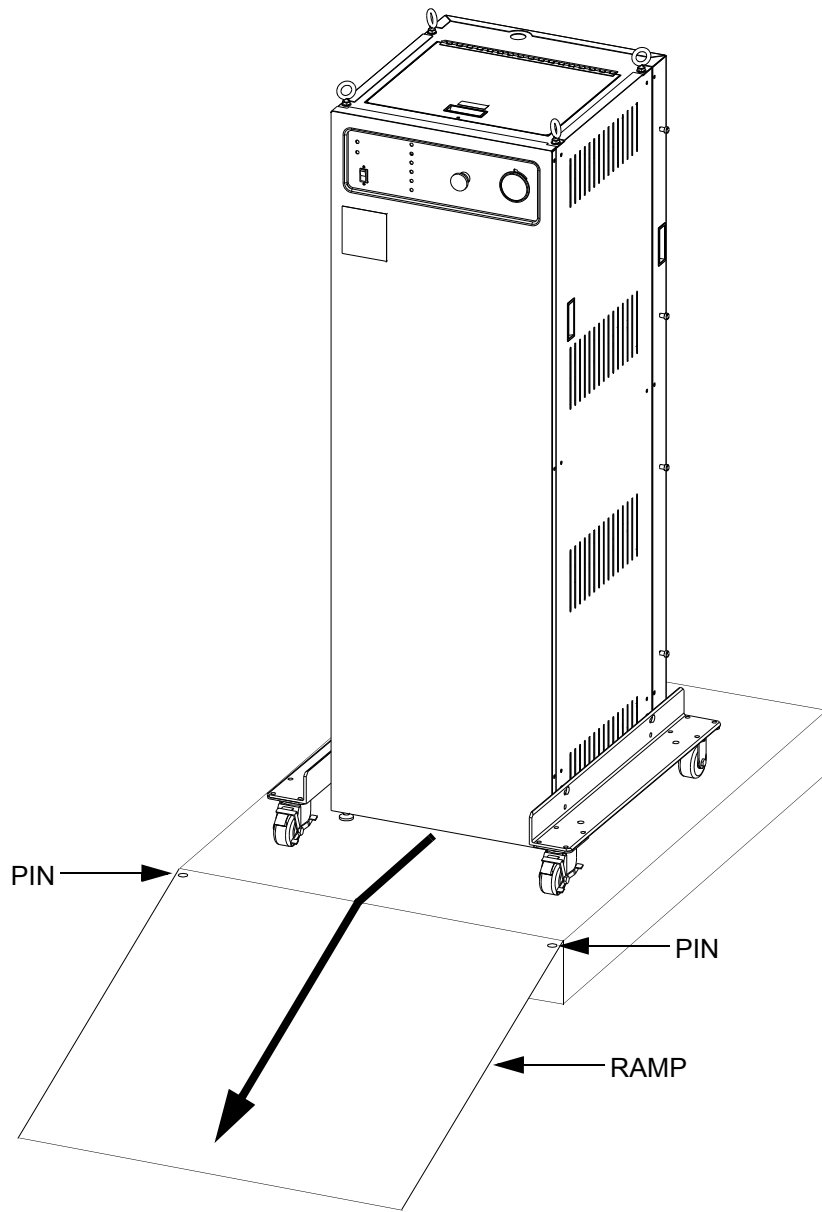
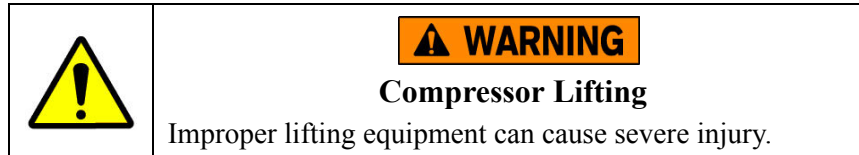

Figure 3-1: Removing the High Capacity Helium Compressor from the Shipping Carton

Alternate Removal Method

The High Capacity Helium Compressor can be lifted from the shipping carton if for some reason the shipping carton ramp cannot be used. Refer to [Figure 3-3-2](#) and use the following alternate procedure to unpack the High Capacity Helium Compressor.



To prevent damage or serious injury from falling equipment, all four eye bolts and four individual lifting strap legs **must** be used when lifting the High Capacity Helium Compressor. **Each** individual lifting strap leg must be a minimum length of 24 inches (61cm) from the eye bolt to the central lifting point. The lifting device and strap leg assembly must have a minimum capacity rating of 900 pounds (405kg).

1. Cut the straps on the exterior of the shipping pallet.
2. Lift the cardboard carton straight up and remove it from the pallet.
3. Cut the strap and remove the bolts that attach the ramp to the shipping pallet.
4. Remove any excess shipping material from around the High Capacity Helium Compressor.
5. Connect lifting strap legs (minimum length of 24 inches each) capable of lifting the compressor to the lifting eyes as shown in [Figure 3-3-2](#).
6. Lift the High Capacity Helium Compressor, and remove the shipping carton pallet from under the High Capacity Helium Compressor.
7. Lower the High Capacity Helium Compressor onto the floor and remove the lifting device from the lifting eyes.
8. Carefully move the High Capacity Helium Compressor into its installation position.
9. Refer to Section 3, Installation, for more information.

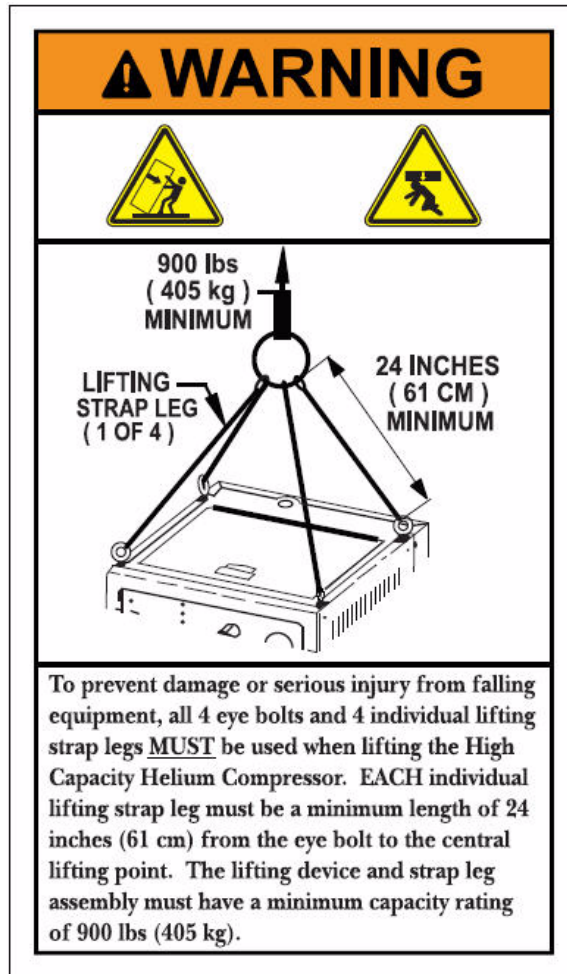

Figure 3-2: Alternate High Capacity Helium Compressor Removal Method

High Capacity Helium Compressor Inspection

Inspect the High Capacity Helium Compressor for visible signs of damage as indicated in the following paragraphs.

Compressor

Inspect the exterior of the High Capacity Helium Compressor for visible signs of damage or evidence of an oil leak. Check the Helium Pressure Gauge for proper helium pressure. Report any damage to the shipping company at once.

Helium Static Pressure Verification

Refer to Section 4, Operation, for more information on the static helium charge pressure of the High Capacity Helium Compressor.

Shipping Carton Contents

The shipping carton should contain the following items:

- High Capacity Helium Compressor
- Installation, Operation, and Maintenance manual

Removing the Wheel Assemblies (Optional)

	<p>⚠ CAUTION</p> <p>Crush Hazard</p> <p>Do not remove the leveling screws from the compressor rack. The unit may become unsteady and possibly crush objects beneath it.</p>
---	---

1. Using a 5/8 inch wrench, adjust the leveling screws to lift the High Capacity Helium Compressor wheel assemblies off the floor as shown in [Figure 3-3-3](#).
2. Remove the four wheel assembly bolts, as shown in [Figure 3-3-3](#), from each wheel assembly. Remove the wheel assemblies from the side of the High Capacity Helium Compressor rack.

Leveling the Compressor

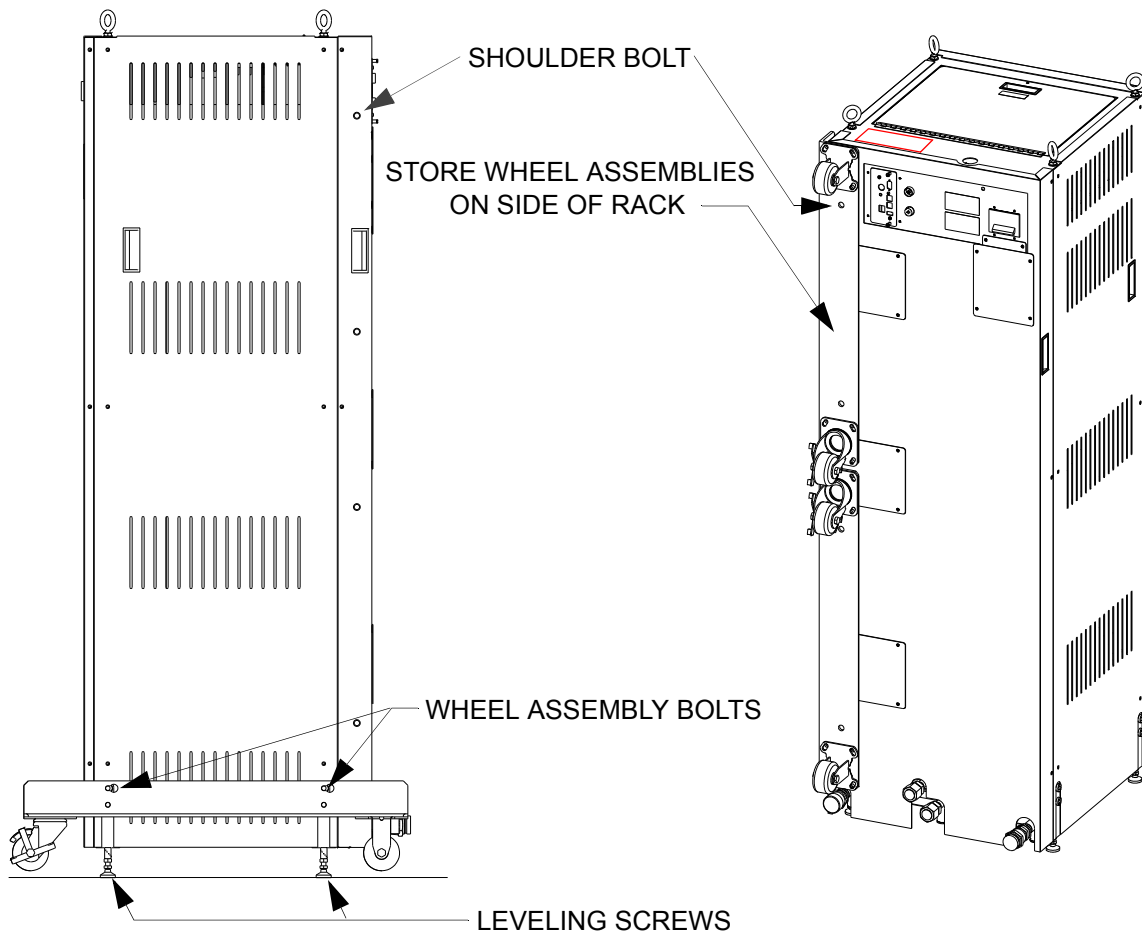

Figure 3-3: Wheel Assembly Bolt Locations

1. Using the leveling screws, lower and level the High Capacity Helium Compressor.
2. Use a 9/16 inch wrench to tighten the leveling screw lock nuts.
3. Store the wheel assemblies on the shoulder bolts on the side of the rack as shown in [Figure 3-3-3](#).
4. Save the wheel assembly bolts.

This Page Left Blank Intentionally

4

Installation

Overview

This chapter provides you with the information required to install the High Capacity Helium Compressor and connect it to multiple On-Board 8F Cryopumps for 300mm PVD configurations.

Chapter Contents

Introduction	4-2
Supply and Return Water Line Connections	4-4
Hard Water Lines	4-4
Flexible Water Lines	4-4
Electrical Connections	4-5
Power Cable Preparation	4-5
Phase Check	4-8
RS-232 Cable Connections (Optional)	4-9
Emergency Off (EMO) System Connections	4-9
Multiple On-Board 8F Cryopump for 300mm PVD Flexline Connections	4-10
Helium Line Connections	4-10

Introduction

The components listed in [Table 4-1](#) are required for High Capacity Helium Compressor installation.

Table 4-1: Required Components for High Capacity Helium Compressor Installation

Item number	Description	Quantity
1	Input power cable as described in Table 1-2 .	length as required
2	Input power cable strain relief	1
3	1/4 inch ring tongue terminal lugs	4
4	3/4 inch female ORS water supply and return fittings	2
5	Connectors for EMO circuit	2

[Figure 4-1](#) highlights the major tasks for High Capacity Helium Compressor installation and refers to the appropriate installation procedures within this section.

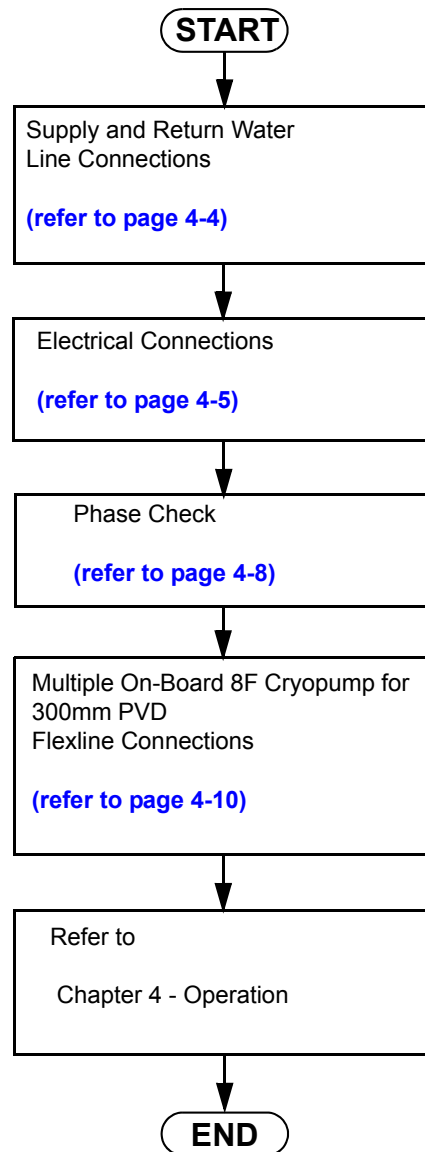

Figure 4-1: High Capacity Helium Compressor Installation Flowchart

Supply and Return Water Line Connections

NOTE: The water used for cooling the High Capacity Helium Compressor must meet the specifications outlined in [Table 1-3](#).

Hard Water Lines

1. Remove the protective cap from the male ORS fitting on the High Capacity Helium Compressor.
2. Make sure the O-ring is located on the male ORS fitting.
3. Install the Supply hard line into the IN connection on the rear panel of the High Capacity Helium Compressor. Tighten the fitting by hand.
4. Install the Return hard line into the OUT connection on the rear panel of the High Capacity Helium Compressor. Tighten the fitting by hand.
5. Using a wrench, tighten the fittings.
6. Turn on the water, and verify that there are no water leaks.

CAUTION

Fittings Damage

Do not overtighten the fittings. Damage to the input and output connector threads can occur.

Flexible Water Lines

1. Remove the protective cap from the male ORS fitting on the High Capacity Helium Compressor.
2. Make sure the O-ring is located on the male ORS fitting.

CAUTION

Barbed Fittings Damage

Do not overtighten the fittings. Damage to the input and output connector threads can occur.

3. Connect the Supply flexible water line to the IN ORS fitting and secure.
4. Connect the Return flexible water line to the OUT ORS fitting and secure.
5. Turn on the water, and verify that there are no water leaks.

Electrical Connections

The following procedures provides information for making the input power connections to the High Capacity Helium Compressor.

Power Cable Preparation

	<p style="text-align: center;">⚠ WARNING</p> <p style="text-align: center;">High Voltage</p> <p>High voltage electric shock could cause severe injury or loss of life.</p>
---	--

<p style="text-align: center;">CAUTION</p> <p style="text-align: center;">Equipment Failure</p> <p>To avoid equipment failure, use appropriate guage wire per local electrical codes and 3 conductor cable with ground rating at 600 VAC for the Compressor.</p>
--

1. Remove the electrical panel cover by turning the four captive 1/4 turn screws as shown in [Figure 4-2](#).
2. Remove the terminal block cover by turning the two 1/4 turn screws. The conductor isolator blocks will be inside the terminal block cover as shown in [Figure 4-2](#).

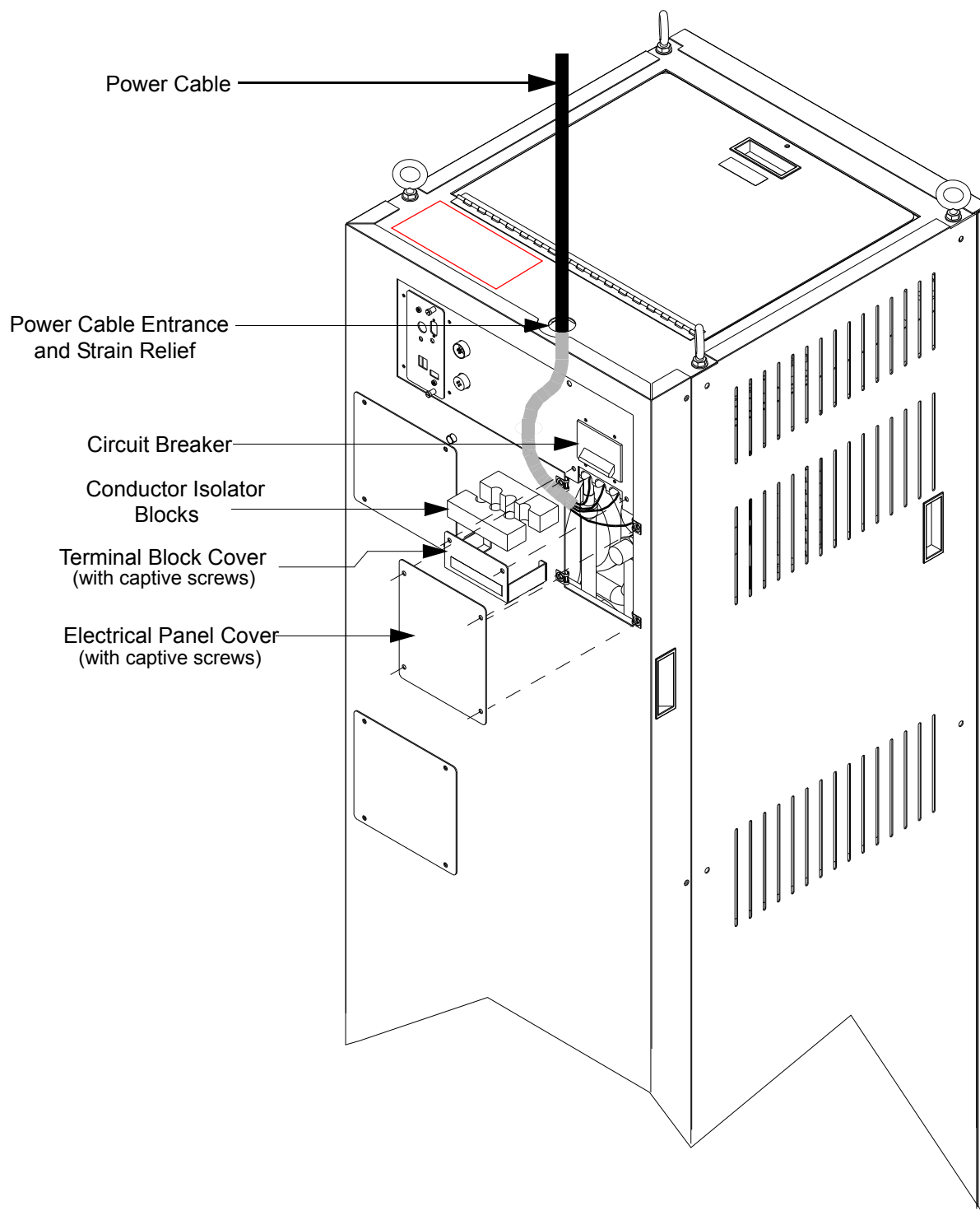



Figure 4-2: High Capacity Helium Compressor Power Cable Connections

3. Refer to [Table 1-4](#) and cut the appropriate cable with ground to an appropriate length.

- Strip the cable jacket back 12 in. (304.8 mm).
- Strip the insulation as required for the terminal lug being used on each individual conductor.
- Install a 1/4 inch ring tongue terminal on the end of each conductor using the appropriate size double crimping tool.
- Install the cable into the High Capacity Helium Compressor through the customer provided strain relief then through the lower hole as shown in [Figure 4-3](#).

	WARNING
	High Voltage High voltage electric shock could cause severe injury or loss of life.

- Remove the 1/4 x 20 nut and install the grounding wire on the ground stud. Install the nut and tighten to 30-35 in.-lbs (3.4-4.0Nm).
- Remove the screws from the High Capacity Helium Compressor circuit breaker terminals X, Y, and Z as shown.

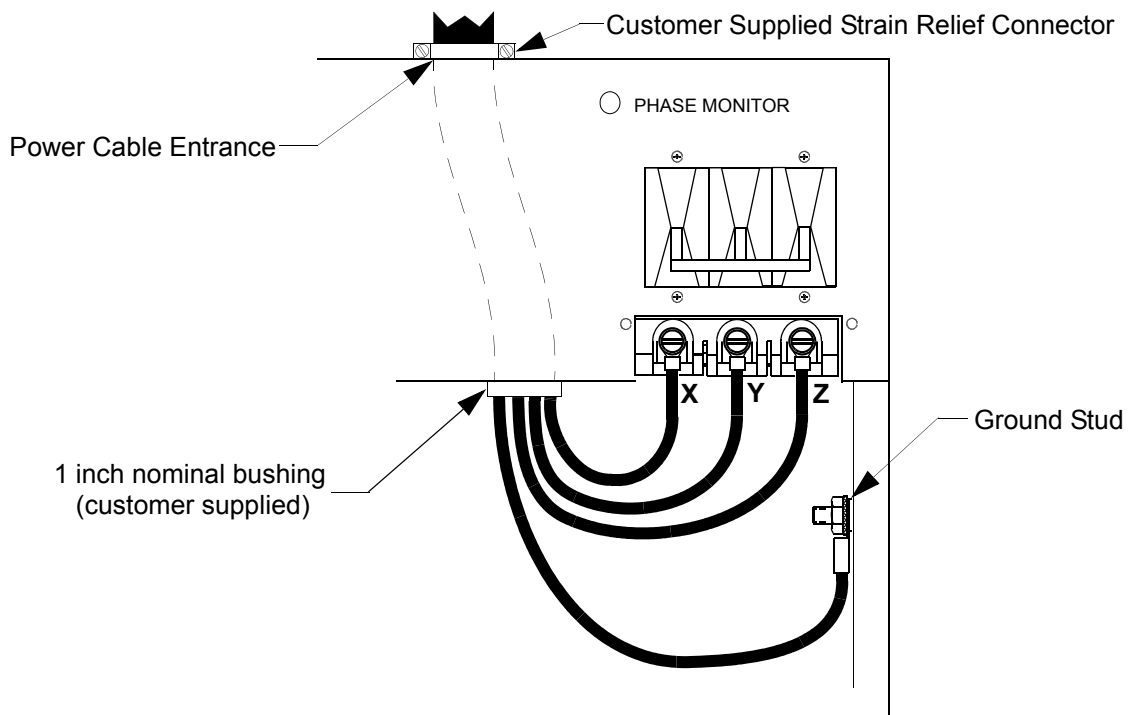



Figure 4-3: Power Cord Installation

NOTE: The phase order in which the conductor terminal lugs are connected to circuit breaker terminals X, Y, and Z will be determined during the Phase Check Procedure.

10. Install the conductor terminal lugs to the circuit breaker terminals X, Y, and Z as shown in [Figure 4-3](#).
11. Torque the screws to 30-35 in.-lbs (3.4-4.0Nm).
12. Leave a service loop of extra cable in the electrical enclosure to prevent strain on the electrical connections. Tighten the clamp on the cable strain relief.
13. Insert and hold 1/2 of the conductor isolator block behind the wires at the circuit breaker terminal block.
14. While holding conductor isolator block, slide the terminal block cover (containing the other conductor isolator block) up so that the conductor isolator blocks fit around the conductors and into the tray within the terminal block cover as shown in [Figure 4-2](#).
15. Reinstall the terminal block cover by rotating the screws 1/4 turn.
16. Reinstall the electrical panel cover by rotating the screws 1/4 turn.
17. Connect the power source end of the power cable according to the local electrical codes.
18. Proceed with **Phase Check**.

Phase Check

	⚠ WARNING High Voltage High voltage electric shock could cause severe injury or loss of life.
---	---

1. Make sure power is supplied to the High Capacity Helium Compressor circuit as described in [Table 1-1](#).
2. Turn the High Capacity Helium Compressor circuit breakers CB1 and CB2 to the ON position. If the High Capacity Helium Compressor does not start and the *REVERSE PHASE* indicator is illuminated, refer to step 3. If the High Capacity Helium Compressor starts, you have completed the phase check procedure.
3. If the High Capacity Helium Compressor does not start and the phase monitor indicator is illuminated, perform the following steps:
 - a. Turn the High Capacity Helium Compressor circuit breakers CB1 and CB2 to the OFF position.
 - b. Disconnect the power cord from the power source.

- c. Remove the electrical panel cover.
- d. Remove the terminal block cover and conductor isolator blocks.
- e. Reverse the wiring order of High Capacity Helium Compressor circuit breaker terminals X and Y.
- f. Torque the circuit breaker terminal screws to 20 in.-lbs.
- g. Install the conductor isolator blocks and terminal block cover.
- h. Install the circuit breaker terminal cover.
- i. Repeat steps 1- 2 of this procedure.

RS-232 Cable Connections (Optional)

Use the following procedure to connect the High Capacity Helium Compressor to the host computer RS-232 network.

NOTE: To meet regulatory compliance, the customer provided RS-232 cable must be fully shielded through to the connector shell. Use cable

1. Connect the RS-232 cable to the RS-232 connector on the compressor electrical box rear panel.
2. Connect the opposite end of the RS-232 cable to the host computer RS-232 network.

Emergency Off (EMO) System Connections

1. Wire the CCJ1/CCP2 connectors as shown in [Figure 4-2](#).

Multiple On-Board 8F Cryopump for 300mm PVD Flexline Connections

CAUTION

Helium Circuit Leak

When connecting or disconnecting helium flex lines, from the 9600 Compressor, use the following procedure and Figure 4-4. Failure to follow this procedure could damage O-ring seals or cause a helium circuit leak.

Helium Line Connections

1. Remove all dust plugs and caps from the Gas Supply and Return lines, the High Capacity Helium Compressor, and the On-Board 8F Cryopump for 300mm PVD SUPPLY and RETURN connectors. Check for the presence of a flat gasket in the male connector, and verify that there is no gasket in the female connector.
2. Connect the Gas Return line to the GAS RETURN connector on the rear of the High Capacity Helium Compressor and then to the GAS RETURN connector on the system helium manifold as shown in Figure 4-4. Tighten the connector.
3. Connect the Gas Supply line to the GAS SUPPLY connector on the rear of the High Capacity Helium Compressor and then to the GAS SUPPLY connector on the system helium manifold as shown in [Figure 4-4](#). Tighten the connector.
4. Attach Supply and Return line identification labels to each end of the appropriate lines.
5. Connect the Gas Return Line to the system helium manifold and then to the Gas Return connector on the On-Board 8F Cryopump for 300mm PVD.
6. Connect the Gas Supply Line to the system helium manifold and then to the Gas Supply connector on the On-Board 8F Cryopump for 300mm PVD.
7. Refer to Section 4, Operation.

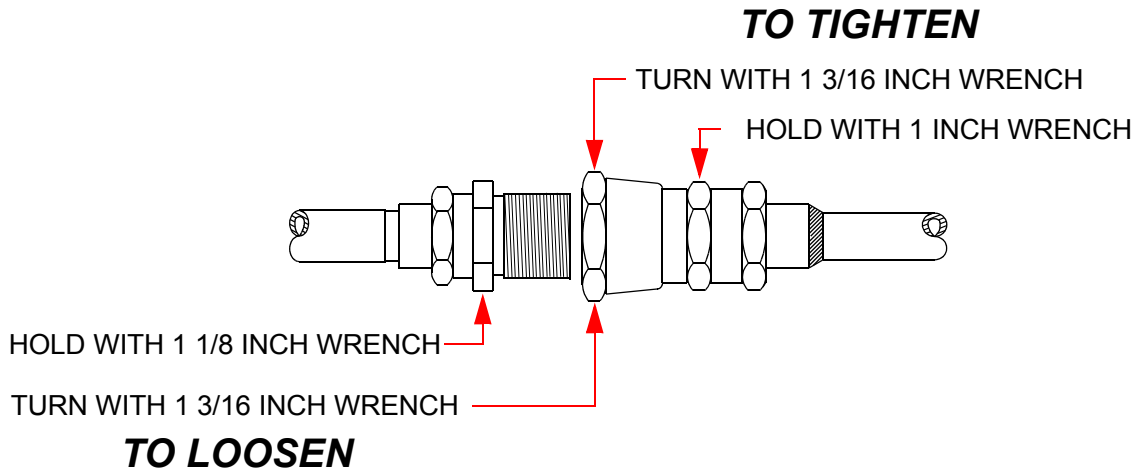

Figure 4-4: Proper Connection/Disconnection Technique for Helium Line Couplings

This Page Left Blank Intentionally

5

Operation

Overview

This chapter provides operating instructions for adjusting system Helium pressure and verifying the static Helium system pressure.

Chapter Contents

Adjusting System Helium Pressure	5-1
Static Helium System Pressure Verification.....	5-2
Start-up	5-2
Shutdown	5-3
Replacement of Helium Circuit Components	5-3

Adjusting System Helium Pressure

The CTI-CRYOGENICS On-Board 8F Cryopump for 300mm PVD system is comprised of several pressurized components i.e. High Capacity Helium Compressor, flex lines, and On-Board 8F Cryopumps for 300mm PVD. Each component is charged with helium before shipment. After all cryopumps, helium lines, and manifolds are attached to the High Capacity Helium Compressor, the system *static helium charge pressure* must be verified *before* system operation. Once the static helium system pressure has been verified, the system is ready for operation. After cooldown, the *normal system operating pressure* should be recorded.

NOTE: The High Capacity Helium Compressor is designed for continuous operation and should remain ON even when the On-Board 8F Cryopumps for 300mm PVD are in a regeneration cycle.

Static Helium System Pressure Verification

The proper system static helium charge pressure is necessary so that the On-Board 8F Cryopump for 300mm PVD operate at optimal performance.

6. Make sure the High Capacity Helium Compressor and On-Board 8F Cryopumps for 300mm PVD are OFF.
7. Make sure all system components are connected together as described in Section 3, Installation.
8. Allow all system components to acclimate to a temperature between 60° F and 80° F (15.5° C - 26.6° C).
9. Read the High Capacity Helium Compressor helium pressure gauge located on the High Capacity Helium Compressor front panel as shown in Figure 1-6. Compare the gauge reading to the helium static charge pressure in Table 1-4.

NOTE: Exceeding the recommended system static helium charge pressure may result in the release of excess helium gas through the safety relief valves of the High Capacity Helium Compressor and On-Board 8F Cryopump for 300mm PVD.

10. If the static helium charge pressure is not within the ranges as indicated in Table 1-4, adjust the charge pressure as described in Section 5, Maintenance.

Start-up

Once the High Capacity Helium Compressor has been installed, the dynamic helium pressure must be verified to ensure proper High Capacity Helium Compressor operation. This procedure should be performed after High Capacity Helium Compressor installation and before normal operation of the On-Board 8F Cryopump for 300mm PVD System.

1. Set the System Circuit Breaker to the ON (UP) position.
2. Set the Control Circuit Breaker to the ON (DOWN) position.
3. Close all Cryopump gate valves.
4. Refer to the **On-Board 8F Cryopump for 300mm PVD Installation, Operation and Maintenance Instructions** CTI-CRYOGENICS P/N 8040509 (that came with your cryopump) and perform the Cryopump start-up procedure.

NOTE: During High Capacity Helium Compressor operation, the High Capacity Helium Compressor gauge reads the return gas pressure.

5. Once the second stage temperatures of all Variable Speed Cryopumps are below 17K, observe the High Capacity Helium Compressor pressure gauge reading. The dynamic helium pressure specification is 200 ±10 psig. If the pressure gauge reading is not

within specification, refer to Section 5, Maintenance, and follow the instructions for Reducing or Increasing Helium pressure based upon the pressure gauge reading.

6. Record the dynamic helium pressure next to the High Capacity Helium Compressor gauge on each High Capacity Helium Compressor. This data is to be verified for each tool installation and whenever a change in number of cryopumps or lengths of helium lines is made.

The High Capacity Helium Compressor pressure reading will increase from the normal system operating pressure during On-Board 8F Cryopump for 300mm PVD regeneration or if fewer On-Board 8F Cryopump for 300mm PVD are being operated. These are normal variations in the High Capacity Helium Compressor pressure reading and should not be cause for concern.

If there is a decrease in system performance, check the *normal system operating pressure* which was determined in step 6.

If the operating pressure is not within the normal value, check the system for leaks.

Once the leaks have been repaired, add helium to return the system to *normal operating system pressure*. Refer to Section 5, Maintenance, for helium charging procedures.

Shutdown

1. Refer to the **On-Board 8F Cryopump for 300mm PVD Installation, Operation and Maintenance Instructions** CTI-CRYOGENICS P/N 8040509 (that came with your cryopump) and perform the Cryopump shutdown procedure.
2. Close all Cryopump gate valves.
3. Set the CB1 Circuit Breaker to the OFF (DOWN) position.
4. Set the CB2 Circuit Breaker to the OFF (UP) position.

Replacement of Helium Circuit Components

On occasion, it may be necessary to replace components such as On-Board 8F Cryopumps for 300mm PVD, helium gas lines or High Capacity Helium Compressors, or change the configuration of the system. Whenever any of these conditions occur, Static Helium System Pressure Verification should be performed to ensure that static helium pressure has not changed.

This Page Left Blank Intentionally

6

Maintenance

Overview

This chapter provides maintenance directions for the Brooks Automation Product.

Chapter Contents

Scheduled Maintenance	6-2
Suggested Maintenance Equipment	6-2
Adsorber Replacement	6-2
Adjusting System Helium Pressure	6-5
Reducing Helium Pressure	6-5
Increasing Helium Pressure	6-5
Adding Helium	6-5

Scheduled Maintenance

Suggested Maintenance Equipment

It is recommended to have the following equipment and disposable supplies available as listed in [Table 6-1](#).

Table 6-1: Suggested Maintenance Equipment

Supply	CTI-CRYOGENICS P/N
Helium, 99.999% pure	—
Pressure regulator (0-3000/0-400 psi) Assy.	8031403
Helium charging line terminating in a 1/4-inch female flare fitting	7021002P001
Torque wrench, 0 to 35 inch-pounds	—
Refer to Appendix A, Customer Support Information, and contact the local Customer Support Center to obtain the CTI-CRYOGENICS parts listed in this table.	

Adsorber Replacement

Use the following procedure to change the adsorbers every three years.

1. Set CB1 and CB2 to the OFF position.
2. Remove the 8 screws that secure the rear panel to the High Capacity Helium Compressor and remove the rear panel.

NOTE: Use two wrenches in Step 3 to prevent loosening the body of the coupling. See [Figure 6-1](#).

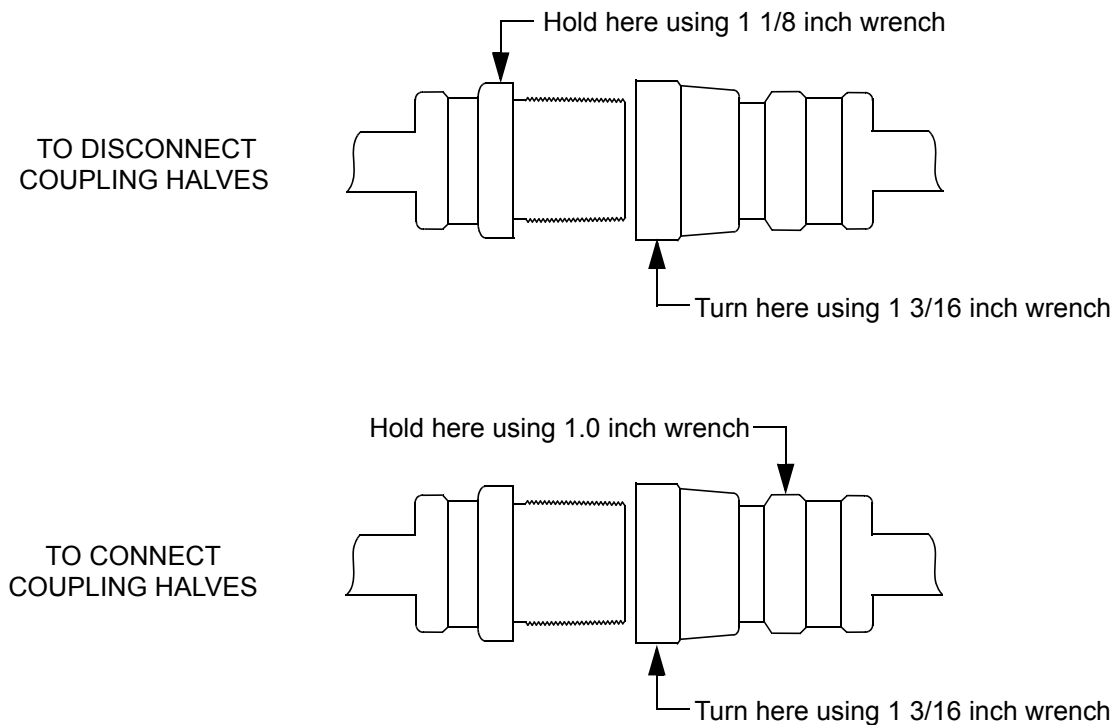

Figure 6-1: Disconnecting/Connecting Self Sealing Couplings

3. For each adsorber, use a 1-3/16 in. wrench, and a 1-1/8 in. wrench, to disconnect the two self sealing couplings, as shown in [Figure 6-2](#).
4. For each adsorber, use a 7/16 in. wrench to remove the adsorber mounting bolt as shown by the arrows in [Figure 6-2](#).
5. Slide the adsorber from under the mounting tabs in the base as shown in [Figure 6-2](#), and remove the three adsorbers from the High Capacity Helium Compressor.
6. Install the replacement adsorbers under the mounting tabs and secure them into place with the bolt removed during Step 4.
7. Check for the presence of a flat gasket in the male connector, and verify that there is no gasket in the female connector.
8. Using two wrenches (see [Figure 6-1](#)), connect the two self sealing couplings on each adsorber.
9. Record the adsorber replacement date on the adsorber label.
10. Install the High Capacity Helium Compressor rear panel.
11. Ensure that the pressure gauge reads the proper value as shown in [Table 1-4](#).
12. If additional gas pressure is required, refer to the Adding Helium section below. If gas pressure needs to be reduced, refer to the Reducing Helium Pressure section below.

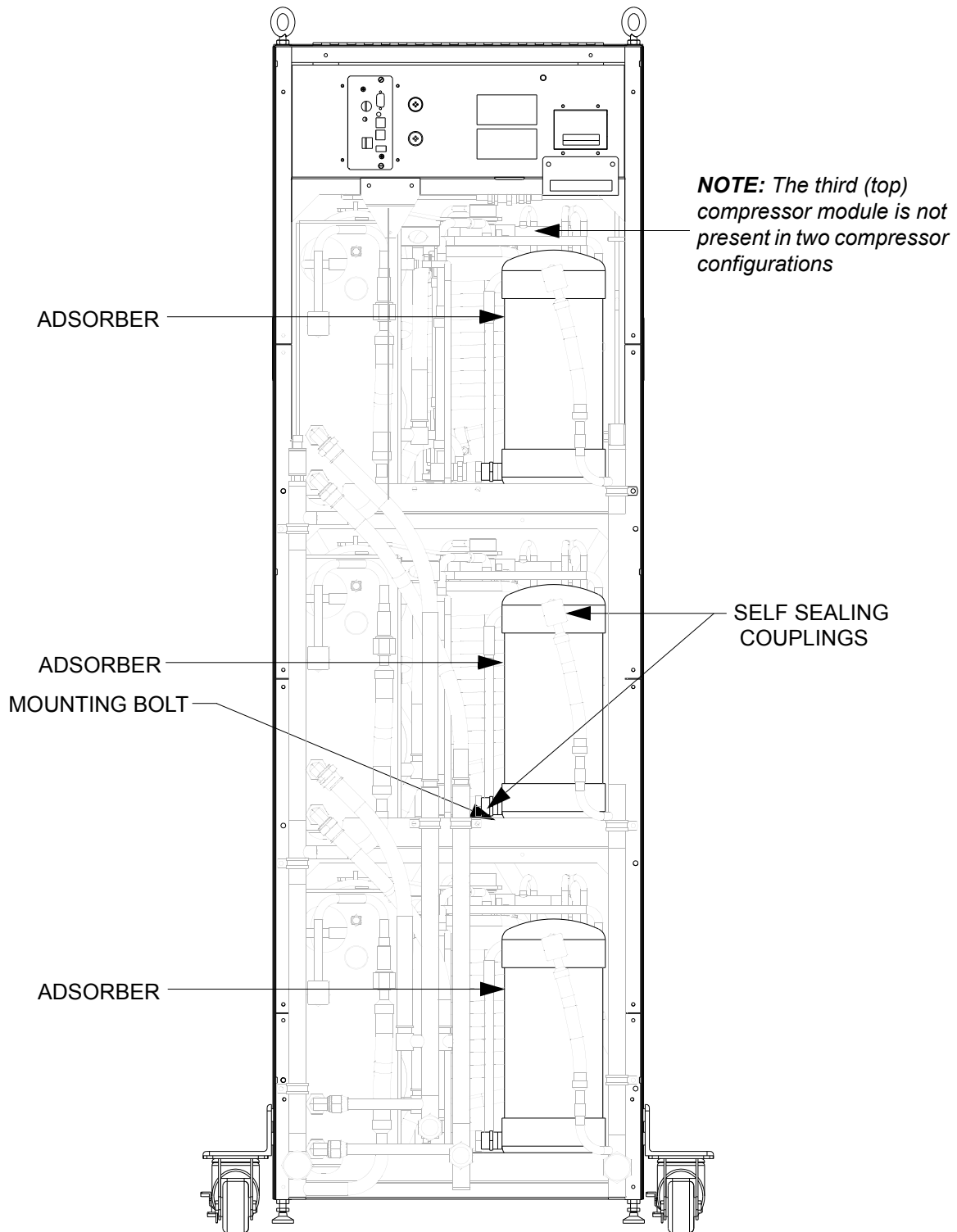

Figure 6-2: Adsorber Location within the High Capacity Helium Compressor
(Rear Panel Removed)

Adjusting System Helium Pressure

NOTE: The helium pressure gauge should be set to the static helium charge pressure value as listed in [Table 1-4](#).

Reducing Helium Pressure

1. Remove the gas charge fitting access panel for the desired pump module.
2. Remove the flare cap from the gas charge fitting.
3. Open the gas charge control valve *very slowly* to allow a slight amount of helium to escape. Leave the valve open until the helium pressure gauge indicates the value as shown in [Table 1-4](#).
4. Close the gas charge valve and install the flare cap.
5. Reinstall the gas charge fitting access panel.

Increasing Helium Pressure

Use the following procedure to increase the helium pressure if the indicated pressure is below the value as shown in [Table 1-4](#).

CAUTION

Helium Leaks

If helium is being added more than once every several months, check for leaks caused by improperly connected self-sealing connections or any mechanical joint in the Compressor.

Adding Helium

This procedure ensures that both the regulator and the charging line will be purged of air and that the air trapped in the regulator will not diffuse back into the helium bottle. For best results, CTI-CRYOGENICS suggests a dedicated helium bottle, regulator, and line, which are never separated, for adding helium.

NOTE: A helium charging line terminating in a 1/4-inch female flare fitting, and a two-stage pressure regulator rated at 0-3000/0-400 psig are required for this procedure.

CAUTION

Helium Circuit Contamination

Use only 99.999% pure helium gas. Helium circuit contamination can result if a lower quality of helium is used.

Attach a regulator (0-3000/0-400 psig) and charging line to a helium bottle (99.999% pure).

NOTE: Do not open the bottle at this time.

6. Purge the regulator and charging lines as follows:
 - a. Open the regulator a small amount by turning the adjusting knob clockwise until it contacts the diaphragm, then turn approximately 1/8 to 1/4 turn more, so that the regulator is slightly open.
 - b. Connect the charge line to the helium pressure regulator.
 - c. Remove one of the gas charge fitting access panels.
 - d. Remove the cap from the gas charge port on the rear of the High Capacity Helium Compressor.
 - e. Loosely connect the charge line to the charge port of the compressor.
 - f. Open any additional valves between the regulator and the charge port.
 - g. Slowly open the helium bottle valve, and purge the regulator and line for 30 seconds.
 - h. Tighten the charge line flare fitting onto the compressor gas charge fitting while the helium is flowing.
7. Set the helium pressure regulator to 350 psig (24.12 bars), and add helium gas as follows:
 - a. Slowly open the gas charge valve.
 - b. When the helium pressure gauge rises to the appropriate helium static pressure value as shown in [Table 1-4](#), close the gas charge valve.
8. Ensure that the helium charge valve on the High Capacity Helium Compressor is tightly closed.
9. Shut off the helium pressure regulator on the helium bottle.
10. Remove the charging line from the compressor charge port.
11. Reinstall the flare cap on the compressor charge port.
12. Reinstall the gas charge fitting access panel.

7

Troubleshooting

Overview

The chapter includes information for troubleshooting the High Capacity Helium Compressor.

Chapter Contents

Troubleshooting the High Capacity Helium Compressor.....7-2
 Technical Inquiries.....7-2

Troubleshooting the High Capacity Helium Compressor

The High Capacity Helium Compressor troubleshooting procedures are summarized in [Table 6-1](#).

Technical Inquiries

Refer to Appendix A of this manual for a complete list of the CTI-Cryogenics' world wide customer support centers.

CAUTION

System Damage

Do not change or modify any High Capacity Helium Compressor internal wiring circuits. Modification of the wiring could damage the High Capacity Helium Compressor or On-Board 8F Cryopump for 300mm PVD system.

Table 6-7: High Capacity Helium Compressor Troubleshooting Procedures

Problem	Possible Cause	Corrective Action
1) Phase light illuminates and unit does not run.	1) Incorrect phasing of input power.	1) Check phasing of input power. Refer to Phase Check in Section 3.
2) Water flow light is lit. (May also see a loss of system refrigeration capacity.)	1) Lack of cooling water 2) Cooling water temperature is too high 3) Compressor water lines hooked up backwards	1) Adjust water flow to specification. Refer to Table 1-3. Shut off the compressor and restart. Monitor the compressor to verify that the condition does not return. 2) Adjust water temperature to specification. Refer to Table 1-3. Shut off the compressor and restart. Monitor the compressor to verify that the condition does not return. 3) Install the water lines correctly.
3) Water flow light is flashing. (May also see a loss of system refrigeration capacity.)	1) Lack of cooling water 2) Cooling water temperature is too high 3) Compressor water lines connected backwards	1) Adjust water flow to specification. Refer to Table 1-3. Shut off the compressor and restart. Monitor the compressor to verify that the condition does not return. 2) Adjust water temperature to specification. Refer to Table 1-3. Shut off the compressor and restart. Monitor the compressor to verify that the condition does not return. 3) Install the water lines correctly.
4) Compressor Temperature light is lit, or is flashing.	1) Possible failed compressor or thermal switch.	1) Refer to Appendix A to contact the Customer Support Center.
5) Low Helium Pressure light is lit and the compressor is running.	1) Return Pressure is below 140PSI.	1) Add Helium. Refer to Adding Helium in Section 5 for instructions.

Table 6-7: High Capacity Helium Compressor Troubleshooting Procedures (Continued)

Problem	Possible Cause	Corrective Action
6) Low Helium Pressure light is lit and the compressor is not running.	1) Return pressure is below 20PSI. (Static pressure will be higher.)	1) Locate and correct the cause of the helium loss. Refer to Adding Helium in Section 5 for instructions.
7) System (CB1) and Control Circuit (CB2) circuit breakers remain in the ON (1) position when switched ON but the High Capacity Helium Compressor will not run.	1) No power coming from source. 2) Insufficient power. 3) EMO has been pushed. 4) Compressor logic Module Failure. 5) Damaged component in the High Capacity Helium Compressor power or control circuit.	1) Check source fuses, circuit breakers, and wiring associated with the power source. Repair as needed. 2) Verify adequate phase-to-phase input voltage. Refer to Table 1-3. 3) Twist the EMO button 1/8 turn counterclockwise to reset the EMO. 4) Turn off CB-2. Remove the compressor logic module. Turn CB-2 on. If unit runs without the logic module, refer to Appendix A to contact the Customer Support Center. 5) Refer to Appendix A to contact the Customer Support Center.
8) System circuit breaker (CB1) will not remain in the ON (1) position when switched ON.	1) Insufficient input voltage 2) Damaged component in the High Capacity Helium Compressor power or control circuit.	1) Verify adequate phase-to-phase input voltage. Refer to Table 1-2. 2) Refer to Appendix A to contact the Customer Support Center.

Table 6-7: High Capacity Helium Compressor Troubleshooting Procedures (Continued)

Problem	Possible Cause	Corrective Action
<p>9) The Control Circuit circuit breaker (CB2) trips.</p>	<p>1) Insufficient input voltage</p> <p>2) Damaged component in the High Capacity Helium Compressor power or control circuit.</p>	<p>1) Verify adequate phase-to-phase input voltage. Refer to Table 1-2.</p> <p>2) Refer to Appendix A to contact the Customer Support Center.</p>
<p>10) System circuit breaker (CB1) remains in the ON position and the High Capacity Helium Compressor stops after several minutes of operation and remains OFF and none of the Status Indicators lights are illuminated.</p>	<p>1) Very cold water has caused a restriction of oil flow through the oil injection orifice during start-up.</p> <p>2) Compressor overload tripped.</p>	<p>1) Adjust water temperature to specification. Refer to Table 1-3. Restart High Capacity Helium Compressor repeatedly until continuous operation is achieved.</p> <p>2) Lift the top electrical chassis cover. Refer to Figure B-3.</p> <p>Check overload reset buttons on the compressor overload switch. Restart the compressor.</p> <p>Verify adequate phase-to-phase input voltage. Refer to Table 1-2.</p> <p>If the problem occurs again, refer to Appendix A to contact the Customer Support Center.</p>

Table 6-7: High Capacity Helium Compressor Troubleshooting Procedures (Continued)

Problem	Possible Cause	Corrective Action
12) Loss of cryopump refrigeration performance and none of the Status Indicators lights are illuminated.	1) Inadequate helium pressure 2) Compressor overload tripped.	1) Refer to Adding Helium in Section 5 for instructions on adjusting the helium pressure. 2) Lift the top electrical chassis cover. Refer to Figure B-3. . Check overload reset buttons on the compressor overload switch. Restart the compressor. Verify adequate phase-to-phase input voltage. Refer to Table 1-2. If the problem occurs again, refer to Appendix A to contact the Customer Support Center.
13) System circuit breaker (CB1) trips after a period of running.	1) Loss or degradation of compressor input power. 2) Damaged component in the High Capacity Helium Compressor power or control circuit.	1) Check that line voltage is correct on all phases. 2) Refer to Appendix A to contact the local Customer Support Center.

8

Appendices

Overview

The following appendices are included to provide the user with a single location for specific information related to the Brooks Automation Product.

Contents

Appendix A: Customer Support Information	9-2
Customer Support Center Locations.	9-2
Guaranteed Up-Time Support (GUTS®)	9-2
Product Information	9-2
E-mail.....	9-2
Appendix B: Diagrams	9-3

Appendix A: Customer Support Information

Customer Support Center Locations

To locate a Customer Support Center near you, please visit our website www.brooks.com on the world wide web and select *CONTACT* on the home page.

Guaranteed Up-Time Support (GUTS®)

For 24-hour, 7-day per week Guaranteed Up-Time Support (GUTS) dial:

1 800-367-4887 - Inside the United States of America

+1 508-337-5599 - Outside the United States of America

Product Information

Please have the following information available when calling so that we may assist you:

- Product Part Number
- Product Serial Number
- Product Application
- Specific Problem Area
- Hours of Operation
- Equipment Type
- Vacuum System Brand/Model/Date of Manufacture

E-mail

For your convenience, you may also e-mail us at:

techsupport@brooks.com

Appendix B: Diagrams

This appendix contains the various hardware, wiring and Helium flow diagrams.

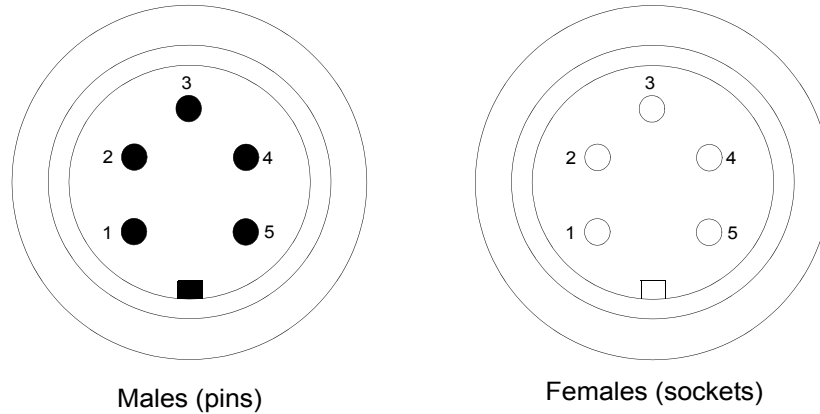

Figure B-1: Logic Module Connector P2 Pinout Diagram

Table B-1: P2 Wiring Data

Pin	Signal	Wire Color
1	Drain	Bare
2	V+	Red
3	V-	Black
4	CAN_H	White
5	CAN_L	Blue

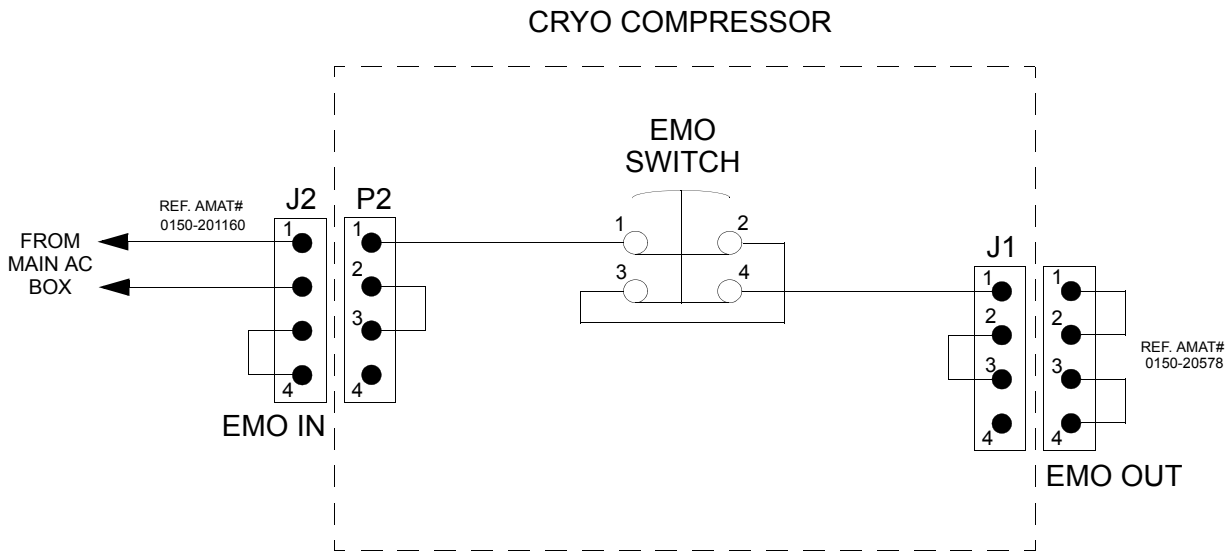

Figure B-2: EMO Connector Schematic

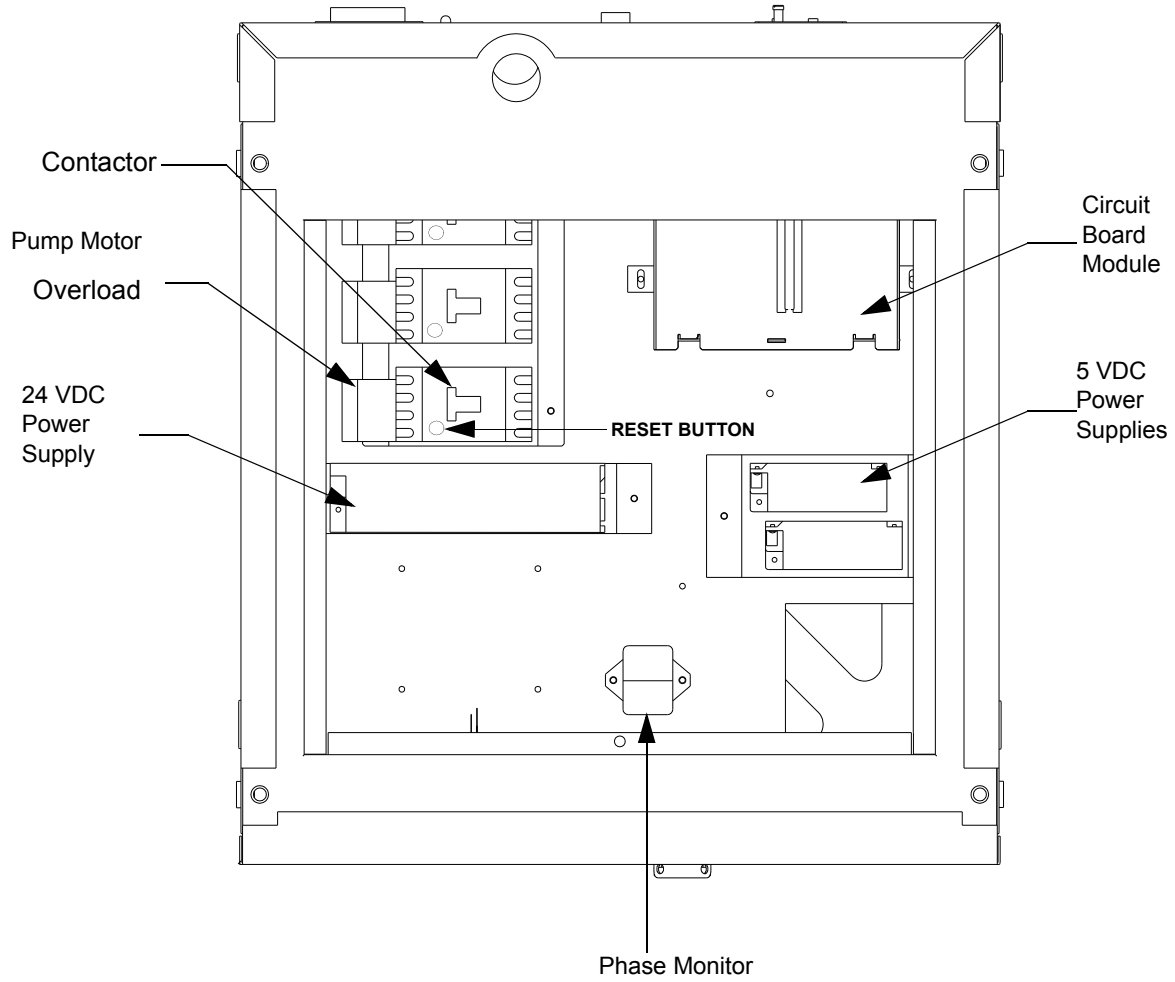

Figure B-3: Tower Compressor Electrical Chassis Top View (Cover Removed)

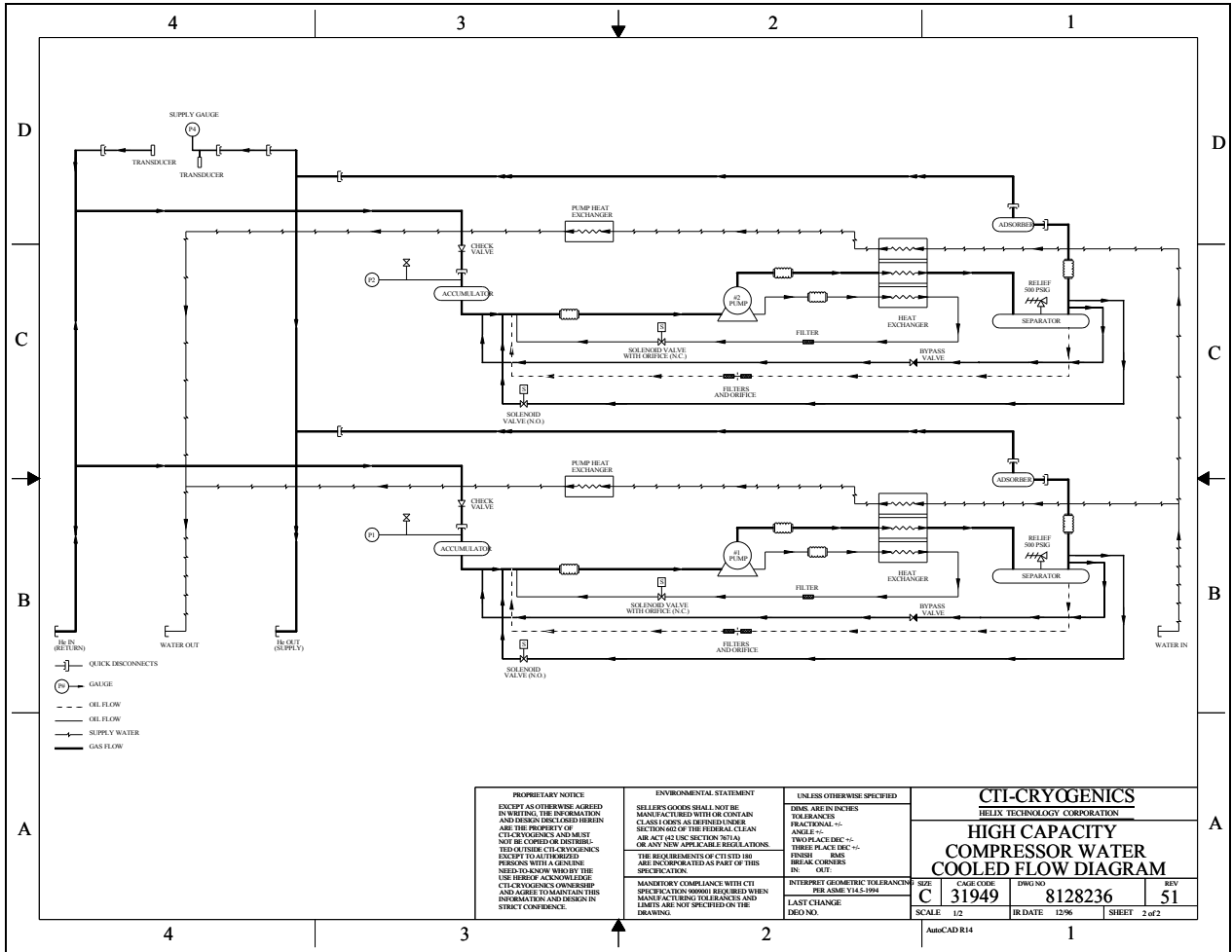

Figure B-4: Helium Flow Diagram - Two Modules

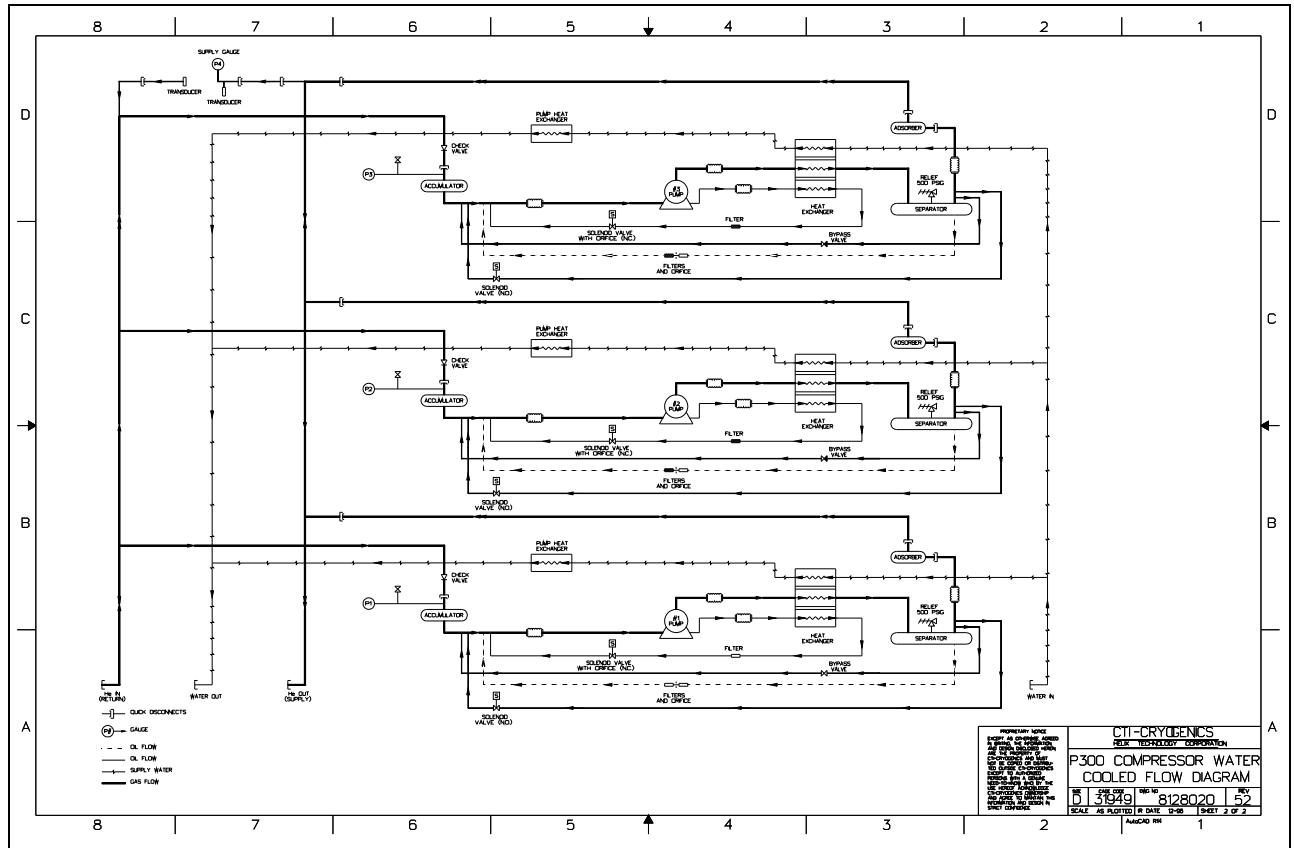

Table B-1: Helium Flow Diagram - Three Modules

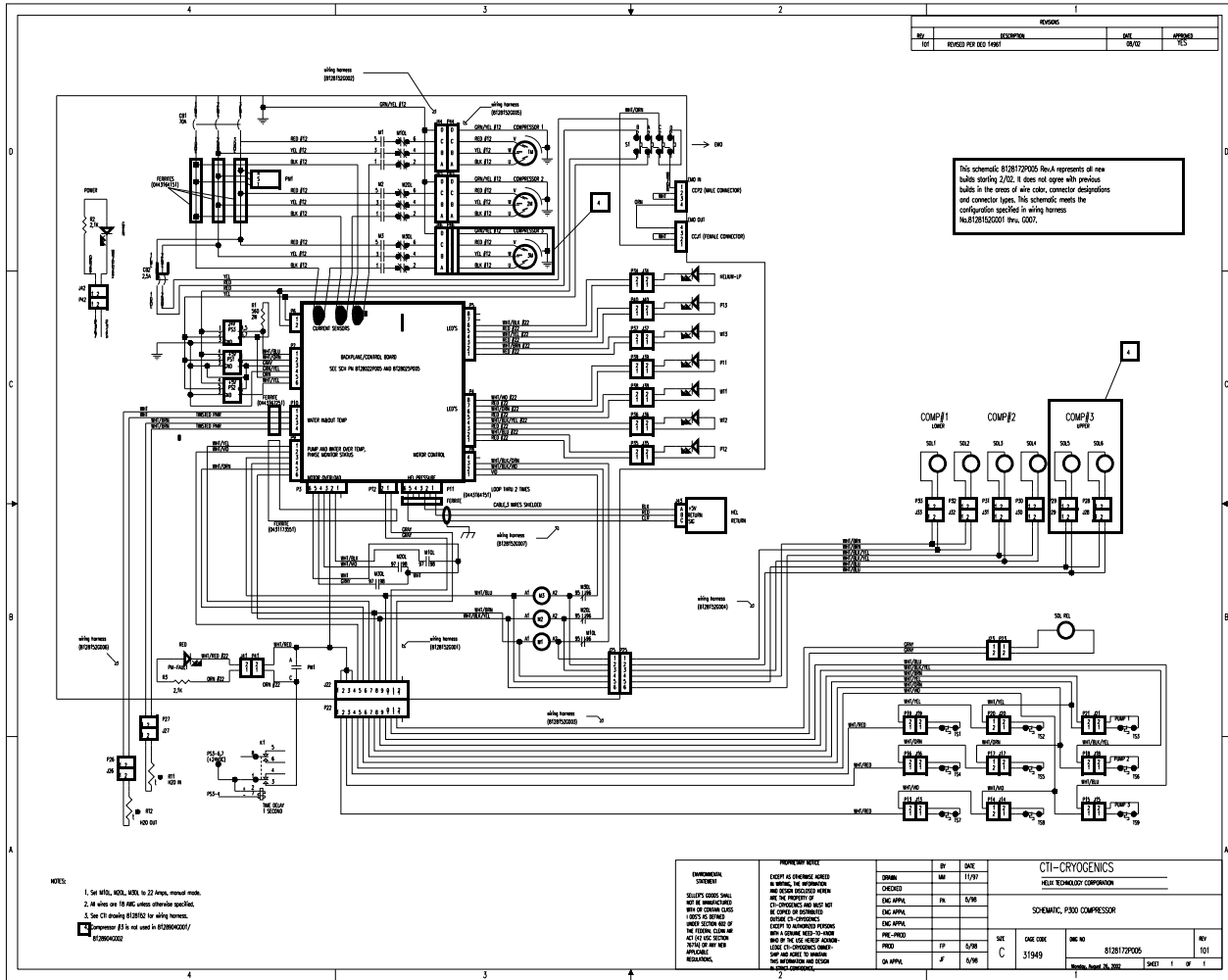

Figure B-5: Low Voltage Electrical Schematic

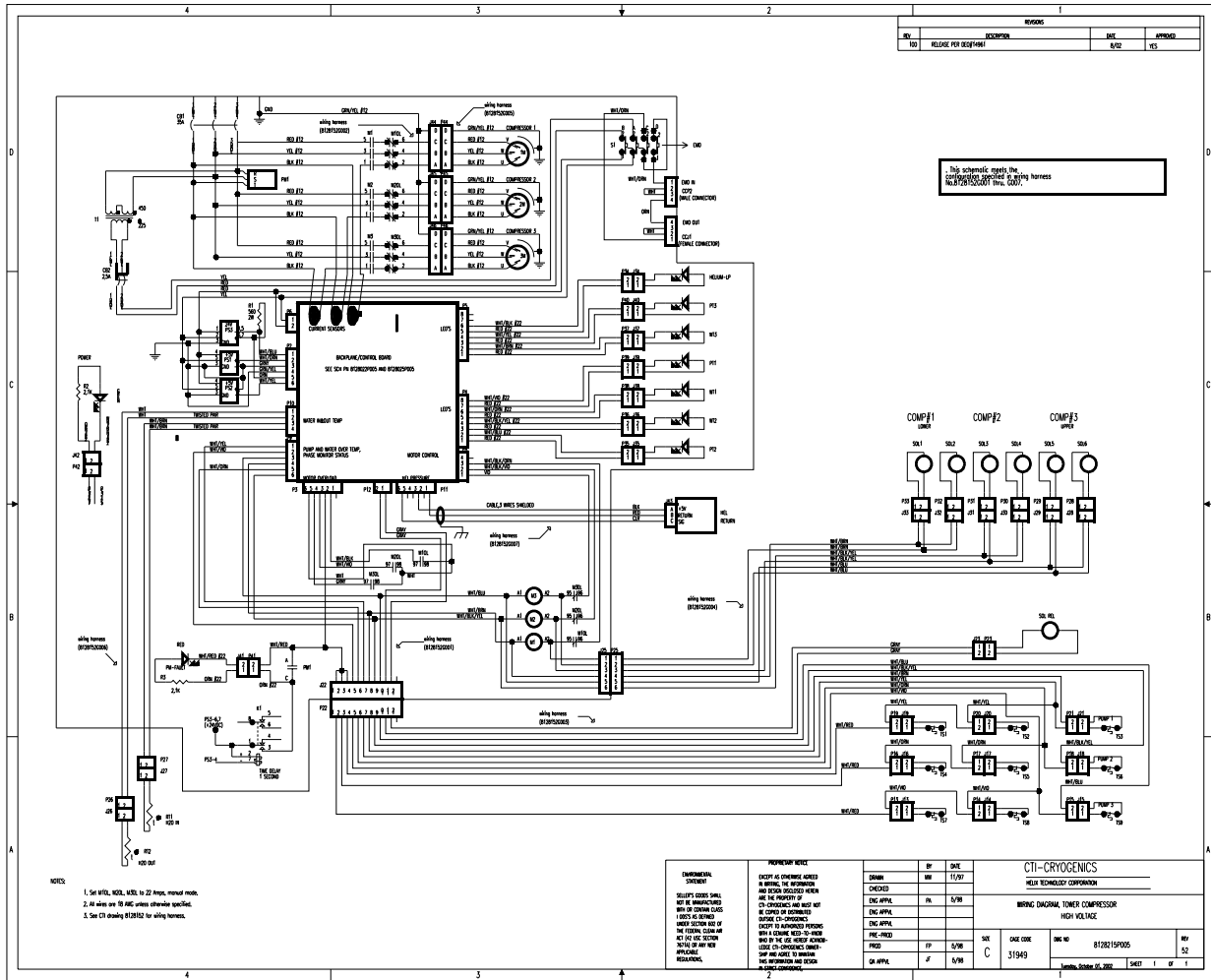

Figure B-6: High Voltage Electrical Schematic

This Page Intentionally Left Blank

Index

A

Adsorbers
replacing 6-2

C

CB1 1-15
CB2 Circuit Breaker 1-12
Circuit breaker
main 1-15
Circuit components, helium
replacing 5-3
Compressor configurations 1-2
Configurations
compressor 1-2
Connector
water in 1-16
water out 1-16
Cooling water specifications 1-7
Couplings
connecting and disconnecting 6-3

D

DeviceNet network 1-14
Dimensions 1-5

E

Electrical box front panel 1-11
Electrical box rear panel 1-13
Electrical specifications 1-6
Emergency off button 1-12
EMO 1-12
EMO Connector Schematic 8-4
EMO connector schematic 8-4
EMO In 1-15
EMO Out 1-15

F

Flex lines, helium
connecting 4-10
Flexible water lines
installing 4-4

H

Hard water lines
installing 4-4
Helium
adding 6-5
Helium charge fitting and charge valve 1-16
Helium circuit components
replacing 5-3
Helium flex lines
connecting 4-10
Helium flow diagram
three modules 8-7
two modules 8-6
Helium Flow Diagram - Three Modules 8-7
Helium Flow Diagram - Two Modules 8-6
Helium in return coupling 1-16
Helium out supply 1-16
Helium pressure
adjusting 5-1
Helium pressure, system
adjusting 6-5, 6-5
Helium, static charge pressure
verifying 5-1
High capacity helium compressor 1-18
High voltage electrical schematic 8-9

I

ID switch 1-14

Input power
 connecting 4-5
Inspecting the compressor 3-6
Installing the compressor 4-2

L
LED indicator 1-13
Lines, flexible
 installing 4-4
Logic module panel 1-13
Low helium pressure indicator 1-11
Low Voltage Electrical Schematic 8-8
Low voltage electrical schematic 8-8

M
Maintenance
 performing 6-2
Media access control switch 1-14

N
Network
 DeviceNet 1-14

O
Operating specifications 1-9

P
P2 Pinout Diagram 8-3
Phase checks
 performing 4-8
Ports
 RS-232 1-13
Power on indicator 1-12

R
Refrigeration system 1-3
Return pressure gauges 1-16
Reverse phase indicator 1-15
RS-232 cables
 connecting 4-9
RS-232 port 1-13

S
Safety precautions 2-2
Schematics
 EMO connector 8-4
 helium flow diagram, three modules 8-7
 helium flow diagram, two modules 8-6
 high voltage electrical 8-9
 low voltage electrical 8-8
 tower compressor electrical chassis 8-5
Self-sealing couplings
 connecting and disconnecting 6-3
Shutting down the compressor 5-3
Starting the compressor 5-2
Static helium charge pressure
 verifying 5-1
Status indicators 1-12
Supply pressure gauge 1-12
System helium pressure
 adjusting 5-1, 6-5, 6-5

T
Three module configuration 1-18
Tower compressor electrical chassis 8-5
troubleshooting 7-2
Two module configuration 1-18

U
Unpacking the compressor 3-1, 3-2
 alternate removal method 3-4

W
Water In connector 1-16
Water lines, hard
 installing 4-4
Water Out connector 1-16
Weight 1-6
Wheel assemblies
 removing 3-6
Wiring data 8-3